

R7D-AP□

SmartStep servo drive

A new concept in servo systems the smart alternative to stepper motors

- Easy to setup, easy to operate. SmartStep is as easy to use as a stepper motor
- Front-panel switches make settings easy and eliminate the need for time-consuming parameter settings
- Auto-tuning on-line mode, dynamic brake setting, alarm display, high torque performance
- Easy to wire with prebuilt cables
- Oscilloscope available via CX-Drive software (CX-One)
- Windows based configuration and commissioning software



Ratings



- 230 VAC single-phase 30 W to 750 W (2.39 Nm)

System configuration

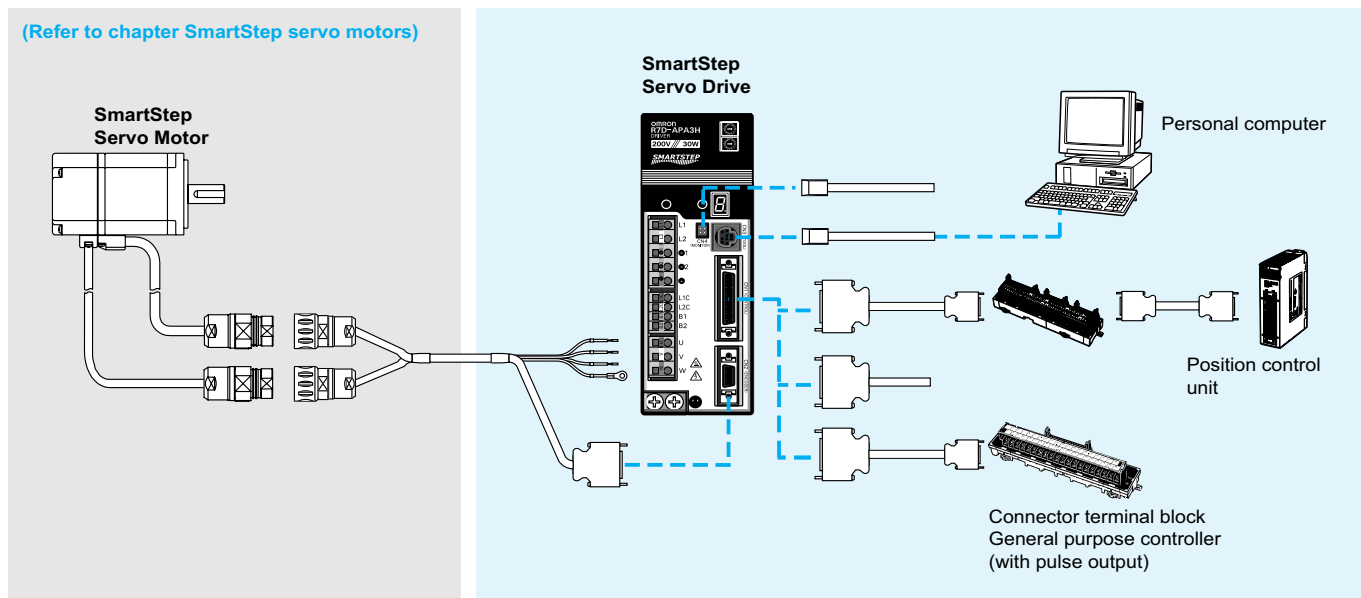
(Refer to chapter SmartStep servo motors)



Servo motor supported

Servo motor			
Family	Voltage	Models rated torque	Remarks
 R7M-A (3000 min ⁻¹)	230 V	0.095 Nm to 2.39 Nm	Refer to the SmartStep servo motors chapter for details
 R7M-AP(3000 min ⁻¹)	230 V	0.318 Nm to 2.39 Nm	Refer to the SmartStep servo motors chapter for details

Servo drive specifications

General specifications

Item	Specification
Ambient operating temperature	0 to 55 °C
Ambient operating humidity	90% max. (with no condensation)
Ambient storage temperature	-20 to 85 °C
Ambient storage humidity	90% max. (with no condensation)
Storage/operating atmosphere	No corrosive gases.
Vibration resistance	10 to 55 Hz in X, Y, and Z directions with 0.1 mm double amplitude or acceleration of 4.9 m/s ² max., whichever is smaller
Impact resistance	Acceleration 19.6 m/s ² max., in X, Y, and Z directions, three times
Insulation resistance	Between power line terminals and case: 0.5 MΩ min. (at 500 VDC)
Dielectric strength	Between power line terminals and case: 1,500 VAC for 1 min at 50/60 Hz Between each control signal and case: 500 VAC for 1 min
Protective structure	Built into panel (IP10).
International standards	Approval obtained for UL, cUL, and EN (EMC directive and low-voltage directive)

Performance specifications

Item	200 VAC input type					
	30 W	50 W	100 W	200 W	400 W	750 W
	R7D-APA3H	R7D-APA5H	R7D-AP01H	R7D-AP02H	R7D-AP04H	R7D-AP08H
Continuous output current (rms)	0.42	0.6	0.89	2.0	2.6	4.4
Momentary maximum output current (rms)	1.3	1.9	2.8	6.0	8.0	13.9
Control power supply	Single-phase 200/230 VAC (170 to 253 V) 50/60 Hz					
Main-circuit power supply	Single-phase 200/230 VAC (170 to 253 V) 50/60 Hz (three-phase 200/230 VAC can be used with the 750 W model.)					
Control method	All-digital servo					
Speed feedback	2,000 pulses/revolution incremental encoder					
Inverter method	PWM method based on IGBT					
PWM frequency	11.7 kHz					
Weight	0.8	0.8	0.8	0.8	1.1	1.7
Compatible motor voltage	200 V					
Compatible motor capacity	30 W	50 W	100 W	200 W	400 W	750 W
Command pulse response	250 kHz					
Applicable servo motor (R7M-)	A03030	A05030	A10030 AP10030	A20030 AP20030	A40030 AP40030	A75030 AP75030

I/O specifications

Terminal specifications

Symbol	Name	Function
L1 and L2 or L1, L2, and L3	Main-circuit power supply terminals	These are the input terminals for the main-circuit power supply.
⊕1	DC reactor terminals	Normally short-circuit between +1 and +2. If harmonic control measures are required, connect a DC reactor between +1 and +2.
⊕2		
⊖	Main-circuit DC output	Do not connect anything to this terminal.
L1C L2C	Control circuit power supply terminals	These are the input terminals for the control power supply.
B1 and B2 or B1, B2, and B3	External regeneration resistance terminals	Connect an external regeneration resistor to these terminals if the regenerative capacity of the internal capacitor is exceeded. (An external regeneration resistor cannot be connected to the 30 to 200 W models.)
U V W	Servo motor terminals	Red
		White
		Blue
⊕	Frame ground	This is the ground terminal.

Control I/O (CN1) specifications

Pin	Symbol	Name	Function
1	+PULS/CW/A	Feed pulses, reverse pulses, or 90° phase difference pulses (A phase)	Line-driver input: 7 mA at 3 V Open-collector input Input impedance: 200 Ω Maximum response frequency: 250 kpps Position control is performed based on the pulses that have been input.
2	-PULS/CW/A		
3	+SIGN/CCW/B	Direction signal, forward pulses, or 90° phase difference pulses (B phase)	Line-driver input: 7 mA at 3 V Open-collector input: 16 mA at 5 V Input impedance: 200 Ω ON: resets deviation counter.
4	-SIGN/CCW/B		
5	+ECRST	Deviation counter reset	Line-driver input: 7 mA at 3 V Open-collector input: 16 mA at 5 V Input impedance: 200 Ω ON: resets deviation counter.
6	-ECRST		
7	BKIR	Brake interlock output	Outputs holding brake timing signals.
8	INP	Positioning completed output	ON when the position error is within the positioning completed range.
10	OGND	Output ground common	Ground common for output signals (pins 7 and 8).
13	+24V	+24 VDC power input for control	Power supply input (+24 VDC) for pins 14 and 18.
14	RUN	RUN command input	ON: servo ON (starts power to servo motor)
18	RESET	Alarm reset input	ON: servo alarm status is reset.
19	GND	RS-422A ground	Ground for RS-422A
20	RXD+	RS-422A reception data	Interface for RS-422A data transfers
21	RXD-		
22	TXD+	RS-422A transmission data	Interface for RS-422A data transfers
23	TXD-		
24	RT	Termination resistance terminal	Connect to RXD- (pin 21) in the unit at the end of the line.
32	Z	Encoder phase-Z open-collector output	Output goes ON when the encoder's phase-Z signal (1 pulse/revolution) is detected. Open-collector output: 20 mA max. at 30 VDC
33	ZCOM		
34	ALM	Alarm output	Output goes OFF when alarm is detected. Open-collector output: 50 mA max. at 30 VDC
35	ALMCOM		
Shell	FG	Cable shield ground	Ground for cable's shield wire.

Encoder connector (CN2) specifications

Pin	Symbol	Name	Function
1, 2, 3	E0V	Encoder power supply GND	Power supply output for encoder
4, 5, 6	E5V	Encoder power supply +5 V	
8	S+	Encoder + phase-S input	Line driver input (conforms to EIA-RS422A) (Input impedance: 220 Ω ± 5%)
9	S-	Encoder - phase-S input	
10	A+	Encoder + phase-A input	Line driver input (conforms to EIA-RS422A) (Input impedance: 220 Ω ± 5%)
11	A-	Encoder - phase-A input	
12	B+	Encoder + phase-B input	Line driver input (conforms to EIA-RS422A) (Input impedance: 220 Ω ± 5%)
13	B-	Encoder - phase-B input	
Shell	FG	Cable shield ground	Ground for cable's shield wire.

Communications connector (CN3) specifications

Pin	Symbol	Name	Function
1	/TXD	Transmission data	Transmission data: RS-232C output
2	/RXD	Reception data	Reception data: RS-232C input
3	PRMU	Unit switching	Switching terminal for a parameter unit
7	+5V	+5 V output	This is the +5 V power supply output to the parameter unit.
8	GND	Ground	
Shell	FG	Cable shield ground	Ground for cable's shield wire.

Monitor output (CN4) specifications

Pin	Symbol	Name	Function
1	NM	Speed monitor	Speed monitor output: 1 V per 1,000 r/min
2	AM	Current monitor	Current monitor: 1 V / rated torque
3	GND	Ground	Grounds for monitor output
4	GND	Ground	

Digital operator specifications

General specifications

Item	Specification
Ambient operating temperature	0 to 55 °C
Ambient operating humidity	90% max. (with no condensation)
Ambient storage temperature	-20 to 85 °C
Ambient storage humidity	90% max. (with no condensation)
Storage/operating atmosphere	No corrosive gases.
Vibration resistance	10 to 55 Hz in X, Y, and Z directions with 0.1 mm double amplitude or acceleration of 9.8 m/s ² max., whichever is smaller
Impact resistance	Acceleration 19.6 m/s ² max., in X, Y, and Z directions, three times

Function specifications

Item	Function
Setting mode	Display or change parameter settings.
Monitor mode	Display monitor values.
Execute function mode	Execute each function mode.
Display alarms	Display alarms that have occurred.
Copy parameters	Read or save parameters from the servo drive. Write parameters to the servo drive. Compare parameters in the servo drive with parameters in the parameter unit.

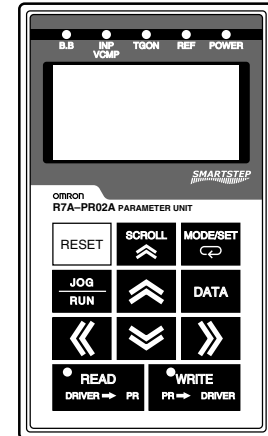

R7A-PR02A

Mode change specifications

Power ON

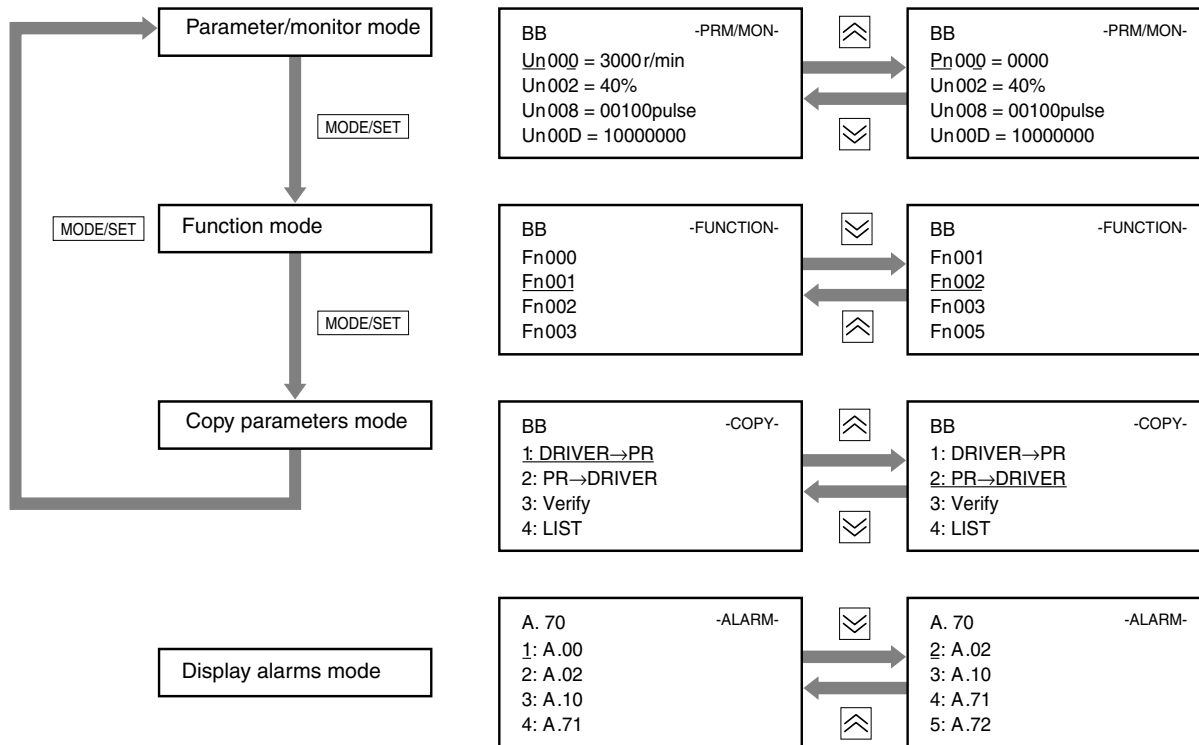

Operation

Components

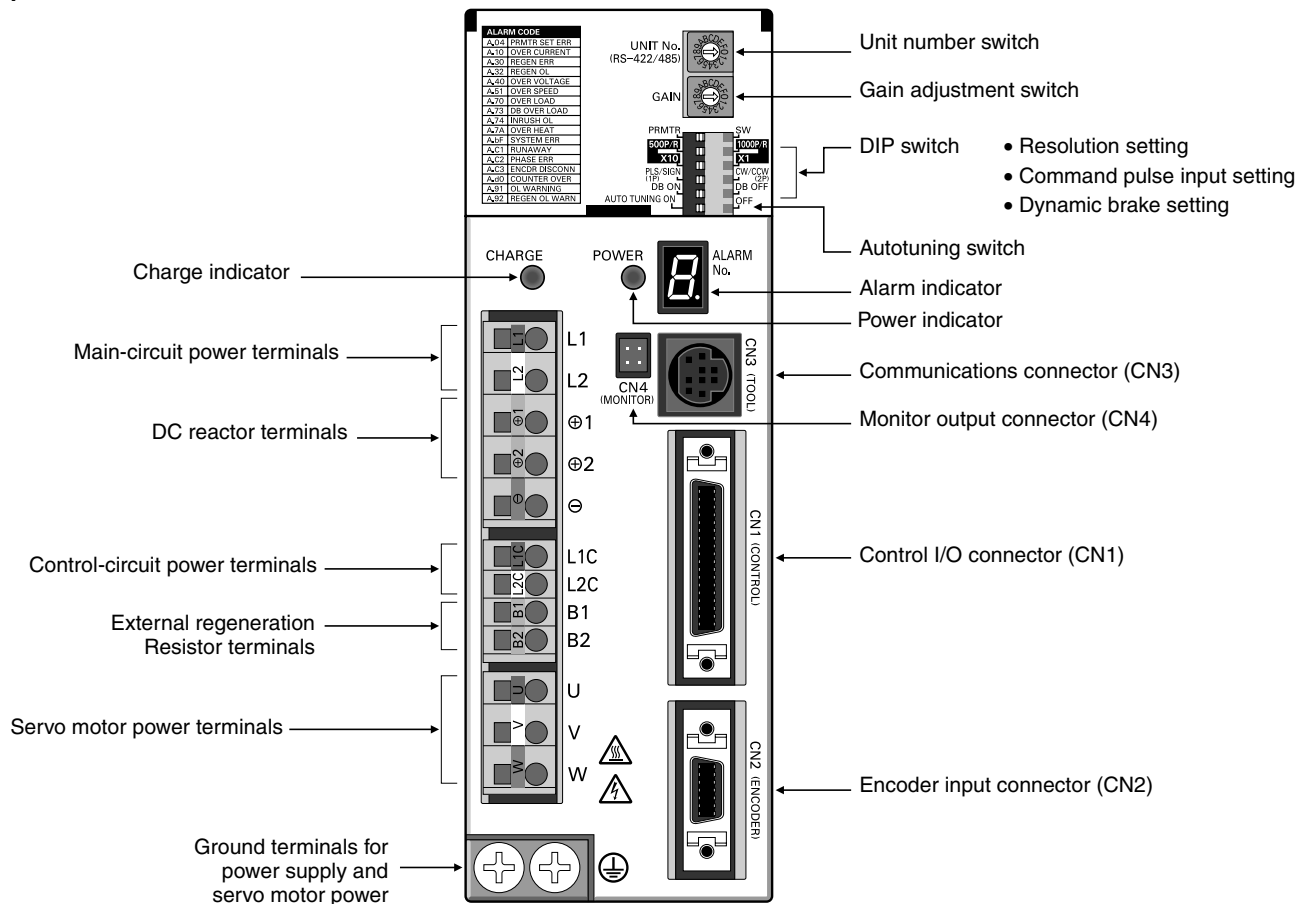

Switch operations

Gain adjustment switch

Adjusts the motor's responsiveness.
 When this switch is set to 0, the unit will operate according to the settings in the internal parameters (Pn100, Pn101, Pn102, and Pn401).
 When this switch is set to 1 through F, the unit will operate according to the rotary switch's setting.

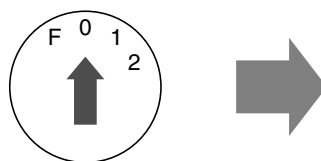

Decrease the switch setting to lower the motor's responsiveness (i.e., so that it moves more smoothly).
 Increase the switch setting to raise the motor's responsiveness (i.e., so that it moves faster).

Setting	Position loop gain	Speed loop gain	Speed loop integral constant	Torque command filter time constant
0	Enables parameter settings (including settings other than gain settings).			
1	15	15	4,000	250
2	20	20	3,500	200
3	30	30	3,000	150
4	40	40	2,000	100
5	60	60	1,500	70
6	85	85	1,000	50
7	120	120	800	30
8	160	160	600	20
9	200	200	500	15
A	250	250	400	10
B	250	250	400	10
C	250	250	400	10
D	250	250	400	10
E	250	250	400	10
F	250	250	400	10

Enable switch/parameter setting

Pin 6 of the DIP switch selects whether the servo drive operates according to the DIP switch settings or parameter settings.

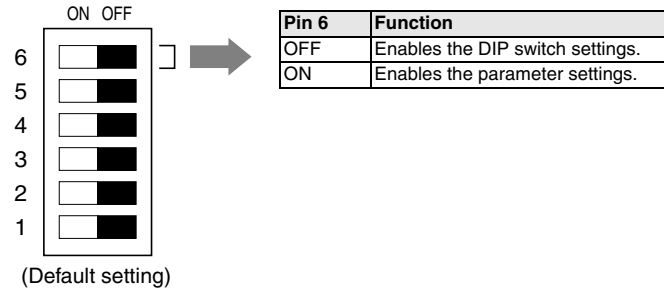

Command pulse input setting

Pin 3 selects the command pulse mode. Select "Forward pulse/reverse pulse: positive logic" or "feed pulses/direction signal: positive logic."

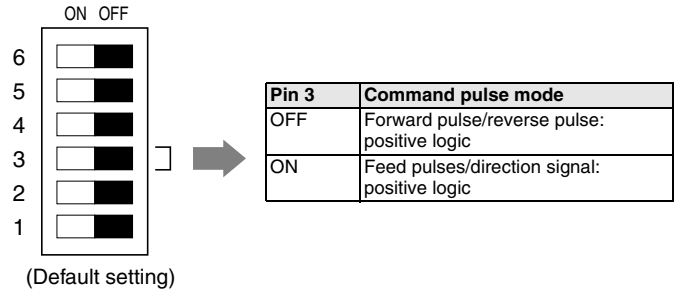

Online autotuning setting

The autotuning switch selects whether the gain will be adjusted automatically during operation.

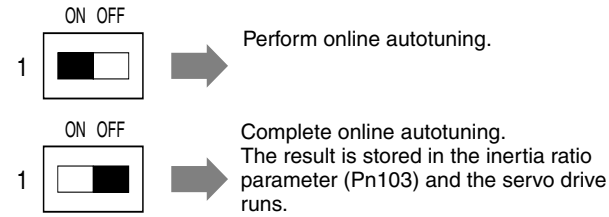

Dynamic brake setting

Pin 2 enables or disables dynamic brake operation. If the dynamic brake is enabled, the motor can be brought to an emergency stop when the RUN command goes OFF or an alarm occurs.

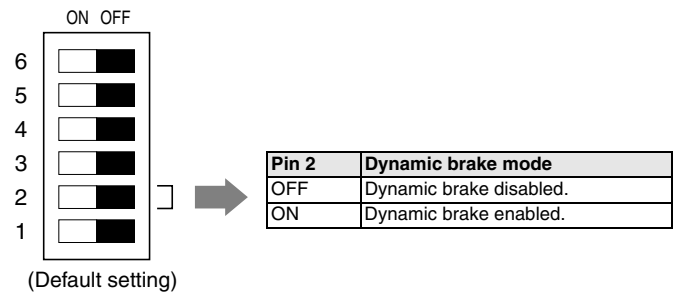

Resolution setting

Pins 4 and 5 select the positioning resolution. If the resolution is set to 1,000 (the default setting), the motor makes one revolution for every 1,000 pulses input.

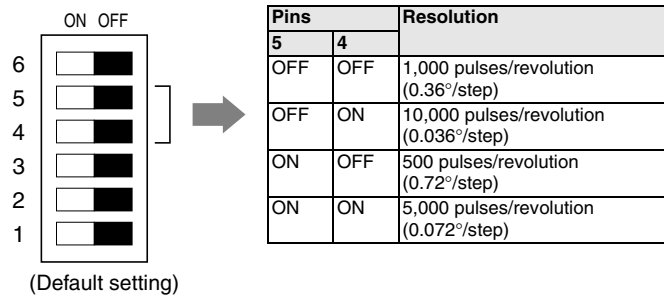

Alarm Table

Display	ALM output	Error detection function
A.04*	OFF	Parameter setting error
A.10*	OFF	Overcurrent
A.30	OFF	Regeneration error
A.32	OFF	Regeneration overload
A.40	OFF	Overvoltage/undervoltage
A.51	OFF	Overspeed
A.70	OFF	Overload
A.73	OFF	Dynamic brake overload
A.74	OFF	Inrush resistance overload

Display	ALM output	Error detection function
A.7A	OFF	Overheat
A.bF*	OFF	System error
A.C1	OFF	Runaway detected
A.C2*	OFF	Phase not detected
A.C3*	OFF	Encoder disconnect detected
A.d0	OFF	Deviation counter overflow
CPF00	---	Parameter unit transmission error 1
CPF01	---	Parameter unit transmission error 2
A.91	---	Overload warning
A.92	---	Regeneration overload warning

Note: 1. These parameters are read when the power is turned ON. Parameter Pn110.2 is valid when online.

2. When using a regeneration resistor, set the resistor's capacity when the temperature has risen to 120 °C. Set this parameter to 0 if a regeneration resistor is not being used.

Installation

Single-phase 200 to 230 VAC +10%/-15% (50/60 Hz)
 (the 750 W servo drives can input three-phase 200 to 230 VAC.)

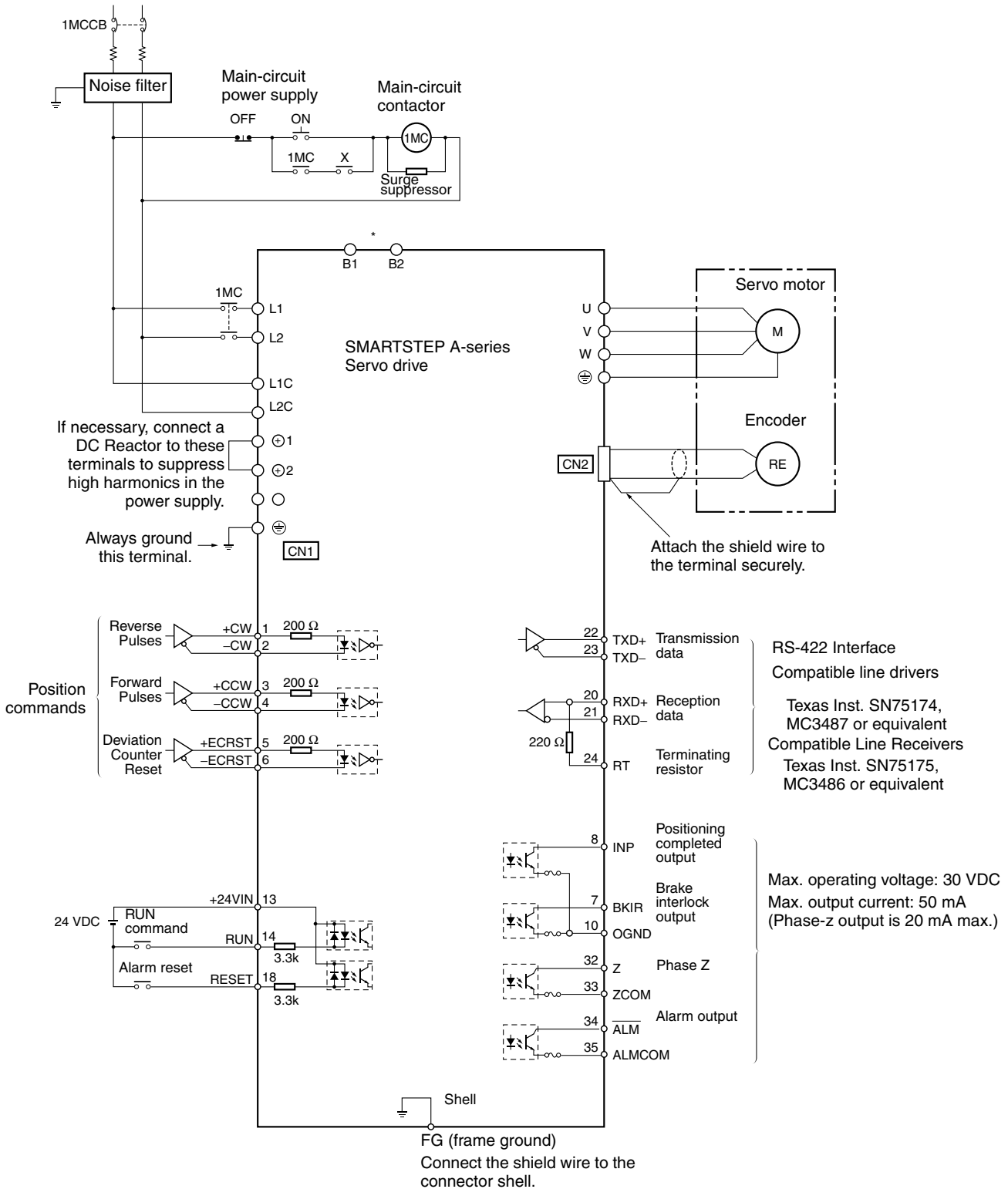

Note: * A regeneration resistor can be connected across the B1 and B2 terminals with 400 W and 750 W servo drives. When using an external regeneration resistor with a 400 W servo drive, just connect it across the B1 and B2 terminals. When using an external regeneration resistor with a 750 W servo drive, remove the jumper bar from the B2 and B3 terminals and then connect the regeneration resistor across the B1 and B2 terminals.

Control cables (for CN1)

Symbol	Name	Compatible units	Model	Available lengths
④	Servo relay unit	Use with position control units (doesn't support communications functions.) Units: CS1W-NC113/133, CJ1W-NC113/133, C200HW-NC113, and C200H-NC112	XW2B-20J6-1B (1 axis)	---
		Use with position control units (doesn't support communications functions.) Units: CS1W-NC213/233/413/433, CJ1W-NC213/233/413/433, C200HW-NC213/413, C500-NC113/211, and C200H-NC211	XW2B-40J6-2B (2 axes)	
		Use with position control units (doesn't support communications functions.) Units: CQM1H-PLB21, and CQM1-CPU43-V1	XW2B-20J6-3B (1 axis)	
		Use with position control units (supports communications functions.) Units: CS1W-NC213/233/413/433, CJ1W-NC213/233/413/433	XW2B-40J6-4A (2 axes)	
		Use with CJ1M-CPU22/23 (doesn't support communications functions.)	XW2B-20J6-8A (1 axis) XW2B-40J6-9A (2 axes)	
⑤	Cable to servo drive	Doesn't support communications functions. (For the XW2B-□□J6-□B)	XW2Z-□□□J-B5	1 m or 2 m (the cable length goes in the empty boxes.)
		Supports communications functions. (For the XW2B-□□J6-4B)	XW2Z-□□□J-B7	
⑥	Cable to position control unit	CQM1H-PLB21 and CQM1-CPU43-V1	XW2Z-□□□J-A3	0.5 m or 1 m (the cable length goes in the empty boxes.)
		C200H-NC112	XW2Z-□□□J-A4	
		C200H-NC211 and C500-NC113/211	XW2Z-□□□J-A5	
		CS1W-NC113 and C200HW-NC113	XW2Z-□□□J-A8	
		CS1W-NC213/413 and C200HW-NC213/413	XW2Z-□□□J-A9	
		CS1W-NC133	XW2Z-□□□J-A12	
		CS1W-NC233/433	XW2Z-□□□J-A13	
		CJ1W-NC113	XW2Z-□□□J-A16	
		CJ1W-NC213/413	XW2Z-□□□J-A17	
		CJ1W-NC133	XW2Z-□□□J-A20	
		CS1W-NC233/433	XW2Z-□□□J-A21	
		CJ1M-CPU22/23	XW2Z-□□□J-A26	
⑦	Control cable	For general-purpose controllers	R88A-CPU□□□S	1 m or 2 m (the cable length goes in the empty boxes.)
			R88A-CTU□□□IN	
⑧	Connector terminal block cable	For general-purpose controllers	R88A-CTU□□□IN	---
	Connector terminal block		XW2B-40F5-P	

Cable for CN3

Symbol	Name	Model
⑨	Computer monitor cable	R7A-CCA002P2

Cable for CN4

Symbol	Name	Model
⑩	Analog monitor cable	R88A-CMW001S

Filters

Symbol	Applicable servo drive	Filter model	Rated current	Rated voltage
⑪	R7D-APA3H, R7D-APA5H, R7D-AP01H, R7D-AP02H	R88A-FIW104-E	4A	250 VAC single phase
	R7D-AP04H	R88A-FIW107-E	7A	
	R7D-AP08H	R88A-FIW115-E	15A	

Connectors

Specifications	Model
Control I/O connector (for CN1)	R88A-CNU01C
SmartStep connectors kit.	Models included in kit R7A-CNA00K-DE
SmartStep encoder connector (for CN2)	R7A-CNA01R
Hypertac power connector female	SPOC-06K-FSDN169
Hypertac encoder connector female	SPOC-17H-FRON169
Hypertac power connector male (used in the motor)	SRUC-06J-MSCN236
Hypertac encoder connector male (used in the motor)	SRUC-17G-MRWN087

External regeneration resistor

Specification	Model
220 W, 47 Ω	R88A-RR22047S

Parameter unit & computer software

Specifications	Model
Parameter copy unit (with cable)	R7A-PR02A
Configuration and monitoring software tool for servo drives and inverters. (CX-drive version 1.11 or higher)	CX-drive
Complete OMRON software package including CX-drive. (CX-One version 1.1 or higher)	CX-One

ALL DIMENSIONS SHOWN ARE IN MILLIMETERS.
To convert millimeters into inches, multiply by 0.03937. To convert grams into ounces, multiply by 0.03527.