

XP series

SCARA robots

SCARA robots for industrial applications:

- Dust-Proof & Drip-Proof Type (IP65).
- Equipped with air ports for air-purging joints X, Y and R axes.
- Higher precision and speed.
- Easier to use.
- Higher rigidity.
- Very compact design.

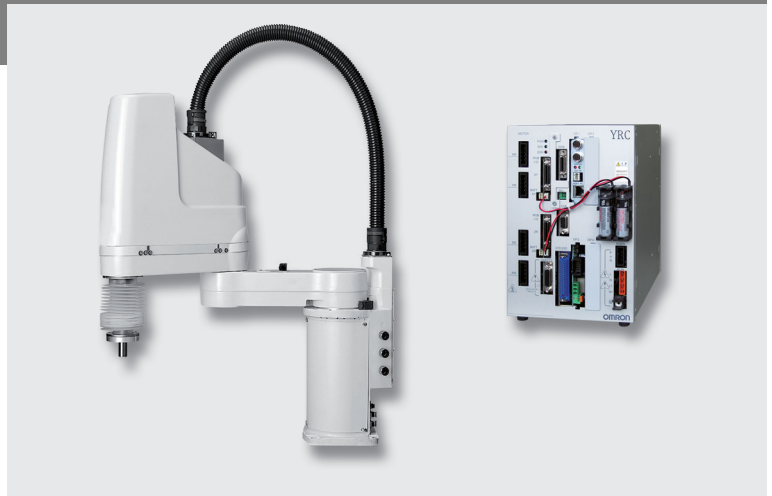

System configuration

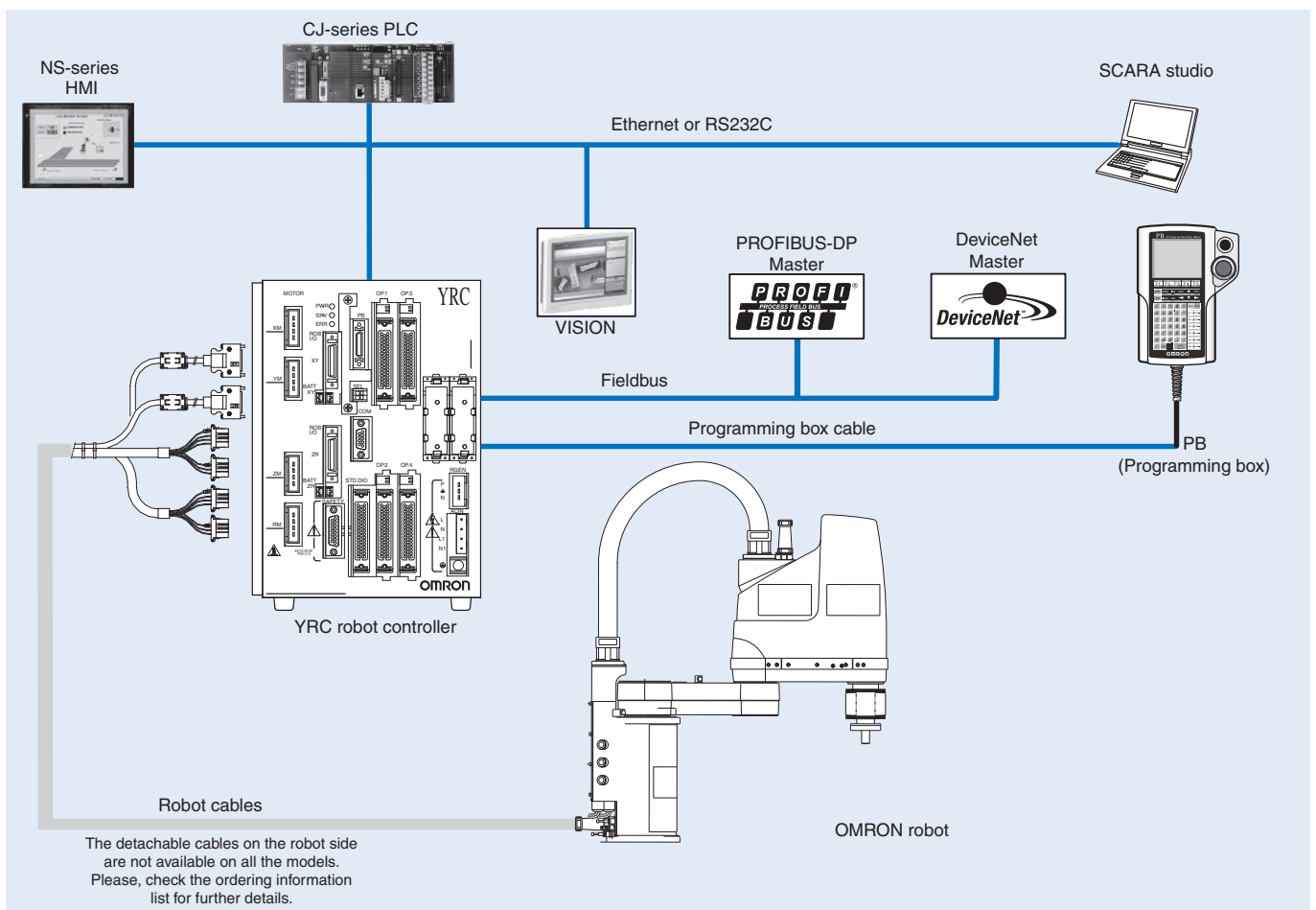

YRC Robot controller

Specifications

Item	Description			
YRC	YRC robot controller			
Basic specifications	Number of controllable axes			
	4 axes maximum (Control simultaneously: 4 axes)			
	Controllable robots			
	SCARA robots			
	Maximum power consumption			
	2500 VA			
Capacity of the connected motor				
1600 W				
Dimensions (WxHxD)				
180x250x235 mm				
Weight				
6.5 kg				
Input power supply	Control power supply	Single phase AC200 to 230 V +/-10% maximum (50/60 Hz)		
	Motor power supply	Single phase AC200 to 230 V +/-10% maximum (50/60 Hz)		
Axis control	Drive method			
	AC full-digital software servo			
	Position detection method			
	Multi-turn resolver with data backup function, Magnetic linear scale			
	Operating method			
	PTP (Point to point), Linear interpolation, Circular interpolation, ARCH			
	Coordinate system			
	Joint coordinates, Cartesian coordinates			
	Position indication units			
Pulses, mm (millimeters), deg (degrees)				
Speed setting				
1% to 100% (In units of 1%. However speed is in units of 0.01% during single-axis operation by DRIVE statement)				
Acceleration setting				
1. Automatic acceleration setting based on robot model type and end mass parameter 2. Setting based on acceleration and deceleration parameter (Setting by 1% unit)				
Resolution				
16384 P/rev, 1 micron				
Origin search method				
Incremental, absolute, semi-absolute				
Program	Program language			
	PSEUDO-BASIC (Conforming to JIS B8439 SLIM Language)			
	Multitasks			
	8 tasks maximum			
Sequence program				
1 program				
Point-data input method				
Manual data input (coordinate value input), Direct teaching, Teaching playback				
Memory	Memory capacity			
	364 KB (total capacity of program and points) (available program capacity during use of maximum number of points is 84 KB)			
	Programs			
	100 program (Max.) 9.999: maximum lines per program 98 KB: maximum capacity per program			
	Points			
10.000 points: maximum number of points				
Memory Backup battery				
Lithium metallic battery (service life 4 years at a 0°C to 40°C)				
Internal flash memory				
512 KB (ALL data only)				
External input/output	STD.DIO	I/O input	General input 16 points, dedicated input 10 points (NPN/PNP specifications selectable)	
		I/O output	General output 8 points, dedicated output 11 points	
	SAFETY		Emergency stop input (Relay contact), Service mode input (NPN/PNP specification is set according to STD.DIO setting)	
	Brake output		Relay contact	
	Origin sensor input		Connectable to DC 24 V normally-closed contact sensor	
	External communications		RS232C: 1CH D-SUB9 (female) RS422: 1CH (Dedicated PB)	
	Options	Slots		4
		Type		Optional input/output (NPN/PNP): General input 24 points / General output 16 points CC-Link: Dedicated input 16 points, Dedicated output 16 points, General input 96 points, General output 96 points (4 nodes occupied) DeviceNet: Dedicated input 16 points, Dedicated output 16 points, General input 96 points, General output 96 points Profibus: Dedicated input 16 points, Dedicated output 16 points, General input 96 points, General output 96 points Ethernet: IEEE802.3 10Mbps (10BASE-T) IVY: Camera input (2ch), camera trigger input, PC connection input Tracking: AB phase input, lighting trigger input, lighting power supply input/output Lighting control: lighting trigger input, lighting power supply input/output
		Programming box		PB (with enable switch)
		Support software for PC		SCARA STUDIO
		Operating temperature		0°C to 40°C
		Storage temperature		-10°C to 65°C
		Operating humidity		35% to 85% RH (non-condensing)
Absolute backup battery		Lithium metallic battery 3.6 V 5400 mAh (2700 mAh x 2)		
Absolute data backup period		1 year (in state with no power applied)		
Noise immunity		IEC61000-4-4 Level 3		
Protective structure		IP10		

YRC-Optional Input/Output unit (PNP/NPN)

Item	Description
R6YACMA241 (NPN) R6YACMA242 (PNP)	Optional Input/Output unit
Optional Input/Output (NPN/PNP)	24 General purpose input, 16 General purpose output

YRC-DeviceNet slave unit

Item	Description	
R6YACDRT01	DeviceNet slave unit	
Applicable controllers	YRC	
Applicable DeviceNet specifications	Volume 1 Release 2.0 / Volume 2 Release 2.0	
Device Profile Name	Generic Device (device number 0)	
Number of occupied CH ^{*1}	Normal: Input/Output 24ch each, Compact: Input/Output 2ch each	
MAC ID setting	0 to 63	
Transmission speed setting	500 Kbps, 250 Kbps, 125 Kbps (set using DIP switch on board)	
DeviceNet I/O ²	Normal	General input 96 points, General output 96 points, Dedicated input 16 points, Dedicated output 16 points
	Compact	General input 16 points, General output 16 points, Dedicated input 16 points, Dedicated output 16 points
Parallel external I/O	The master module and up to four ports can be controlled regardless of the robot program by using the pseudoserialization function	
Network length	Overall length ^{*3}	100 m/500 Kbps, 250 m/250 Kbps, 500 m/125 Kbps
	Branch length / Overall branch length	6 m max./39 m max., 6 m max./78 m max., 6 m max./156 m max.
Monitor LED	MS (Module Status), NS (Network Status)	

*1 Use the robot parameter to select Normal or Compact.

*2 Controller I/O are updated every 10ms.

*3 These values apply when a thick cable is used. The distance is less when a fine cable is used or when thick and fine cables are mixed in use.

YRC-Profibus slave unit

Item	Description
R6YACPRT01	Profibus slave unit
Applicable controllers	YRC
Communication profile	Profibus-DP slave
Number of occupied nodes	1 node
Setting of station address	1 to 99 (set using Rotary switch on board)
Setting of communication speed	9.6 Kbps, 19.2 Kbps, 93.75 Kbps, 187.5 Kbps, 500 Kbps, 1.5 Mbps, 3 Mbps, 6 Mbps, 12 Mbps (automatic recognition)
Profibus I/O ^{*1}	General input 96 points, General output 96 points, Dedicated input 16 points, Dedicated output 16 points
Parallel external I/O	The master module and up to four ports can be controlled regardless of the robot program by using the pseudoserialization function
Overall length	100 m/3 M-6 M-12 Mbps, 200 m/1.5 Mbps, 400 m/500 Kbps, 1000 m/187.5 Kbps, 1200 m/9.6 K- 19.2 K-93.75 Kbps
Monitor LED	RUN, ERR, SD, RD, DATA-EX

*1 The shortest I/O update interval of the controller is 10 ms but the actual I/O update time varies depending on the update time with the master station.

YRC-Ethernet unit

Item	Description
R6YACETN01	Ethernet unit
Applicable controllers	YRC
Network specification	As specified for Ethernet (IEEE802.3)
Connector specification	RJ-45 connector (8-pole modular connector) 1 port
Baud rate	10 Mbps (10BASE-T)
Communication mode	Half Duplex (Half-duplex)
Network protocol	Application layer: TELNET / Transport layer: TCP / IP Network layer: IP, ICMP, ARP / Data link layer: CSMA / CD Physical layer: 10BASE-T
Number of simultaneous log inputs	1
Setting of IP address, etc.	Set from PB
Monitor LED	Run, Collision, Link, Transmit, Receive

YRC-VISION board basic specifications

Item	Description	
R6YACVI01	VISION board	
Basic specifications	Applicable controller	YRC
	Pixels	640 (H) x 480 (V) (300,000 pixels, VGA)
	Settable part types	40 part types
	Connectable cameras	Maximum 2 units ^{*1}
	Camera types	Double speed compatible analog camera
	Memory	128 MB SDRAM, 256 MB miniSD card
	External I/F	Ethernet (100BASE-TX)
Search method	Edge search (Correlative edge filter, Sobel filter)	
Image input	Trigger	S/W trigger, H/W trigger, Camera internal synch
	External trigger input	2 points
Functions	Search function	Position offset, Auto registry of point data
Setup support functions	Calibration, image storage function ^{*2} (all images / specified image)	

*1 If connecting 2 units, then must be the same model.

*2 Requires Windows PC.

Accessories for YRC-VISION board

Item	Description
R6YACS1	CCD CAMERA
R6YACCV003	Camera cable 3.5 m
R6YACCV006	Camera cable 6 m
R6YACCV009	Camera cable 9.5 m (3.5 m + 6 m)
R6YACLE008	Lens 8 mm
R6YACLE012	Lens 12 mm
R6YACLE016	Lens 16 mm
R6YACLE025	Lens 25 mm
R6YACLR005	Close up ring 0.5 mm
R6YACLR010	Close up ring 1.0 mm
R6YACLR020	Close up ring 2.0 mm
R6YACLR050	Close up ring 5.0 mm

YRC-Tracking board basic specifications

Item	Description		
R6YACTR01	Tracking board		
Basic specifications	Lighting control section	Applicable controller	YRC
		Number of lighting connected units	Up to 2 units
		Light adjusting system	PWM control (0 to 100%) (Cycle 60 KHz) Stroboscopic light (10 to 33000 μs)
		Trigger	S/W trigger, H/W trigger
		External trigger input	2 points
		Lighting power input	12 VDC or 24 VDC (Supplied from outside commonly to 2 channels)
		Lighting output	When DC 12 V is supplied: Less than 30 W with 2 channels totaled When DC 24 V is supplied: Less than 60 W with 2 channels totaled
	Pulse input section	Number of encoder connected units	Up to 2 units
		Encoder power source	DC 5 V (Less than 500 mA with 2 channels totaled) (Supplied from controller)
		Applicable encoder	Line driver equivalent to 26LS31 / 26C31 (Conforming to RS422)
		Input phase	A, \bar{A} , B, \bar{B} , Z, \bar{Z}
		Maximum response frequency	2 MHz
		Counter / Step-up multiplication	0 to 65535 / Double, quadruple
		Other	Provided with broken wire detect function

Note: The tracking board is required when using the tracking function.

Accessories for YRC-Tracking board

Item	Description
R6YACCR005	Encoder cable for tracking 10m

YRC-Lighting control board basic specifications

Item	Description	
R6YACLI01	Lighting control board	
Basic specifications	Applicable controller	YRC
	Number of lighting connected units	Up to 2 units
	Light adjusting system	PWM control (0 to 100%) (Cycle 60KHz) Stroboscopic light (10 to 33000us)
	Trigger	S/W trigger, H/W trigger
	External trigger input	2 points
	Lighting power input	12VDC or 24VDC (Supplied from outside commonly to 2 channels)
	Lighting output	When DC12V is supplied: Less than 30W with 2 channels totaled When DC24V is supplied: Less than 60W with 2 channels totaled

Accessories for YRC-PB (Programming box)

Item	Description
R6YACPB005E	Programming box cable 5m
R6YACPB012E	Programming box cable 12m

Accessories for YRC-SCARA studio software

Item	Description
R6YACSSC1	Support software SCARA studio
R6YACCC005	Communication cable 9-9 pin

YRC-Nomenclature

Connector names

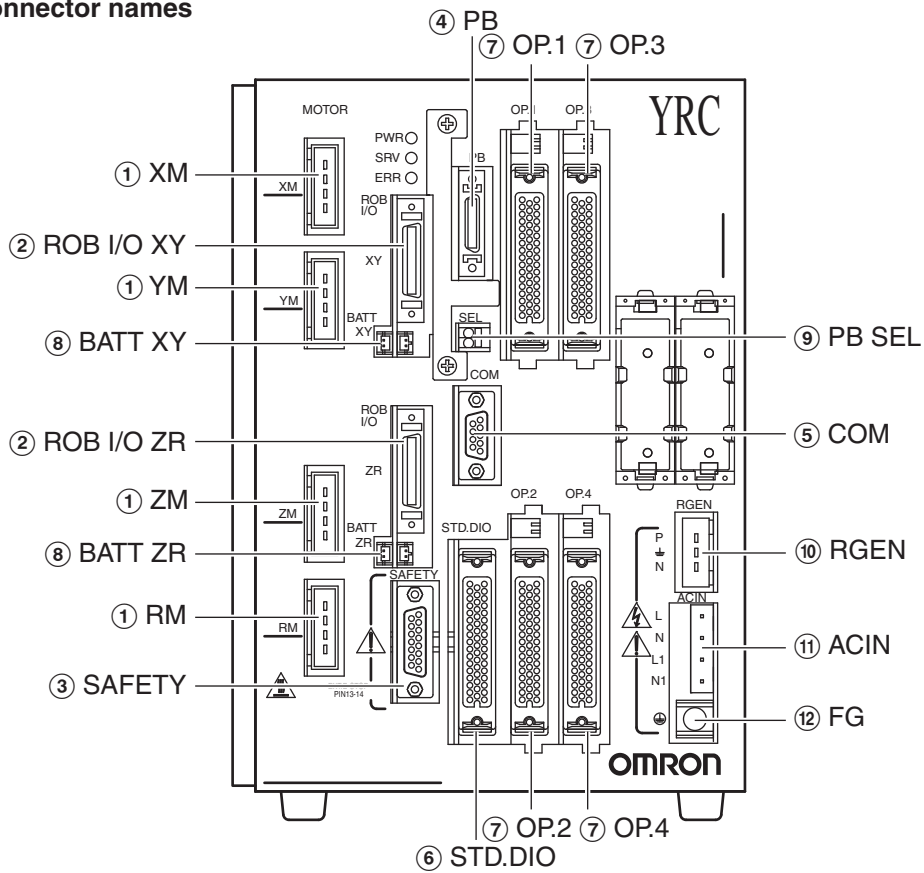

Connector name	Function
① XM/YM/ZM/RM	Connectors for servomotor drive
② ROB I/O [XY/ZR]	Connectors for servomotor feedback and sensor signals
③ SAFETY	Input/output connector for safety function such as emergency stop
④ PB	Connector for PB
⑤ COM	RS-232C interface connector.
⑥ STD.DIO	Connector for dedicated input/output and standard generalpurpose input/output
⑦ OP.1 ,2, 3, 4	Conectors attached to optional expansion I/O boards
⑧ BATT [XY/ZR]	Battery connector for absolute backup
⑨ PB SEL	PB selector switch contact
⑩ RGEN [P/±/N]	Connector for regenerative unit
⑪ AC IN [L/N/L1/N1]	Terminal block for power cable. Use ring-tongue terminals to make connections.
⑫ FG	Ground terminal (⊥) . Provide Class D grounding (100 ohms or less) .

Dimensions

Standard YRC

Top view

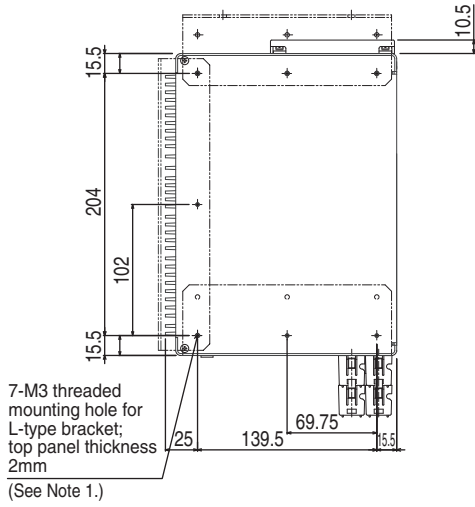

Front view

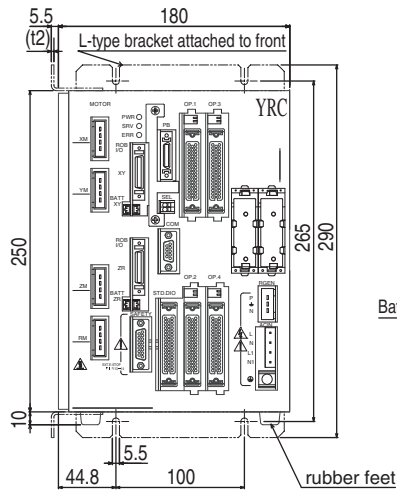

Side view

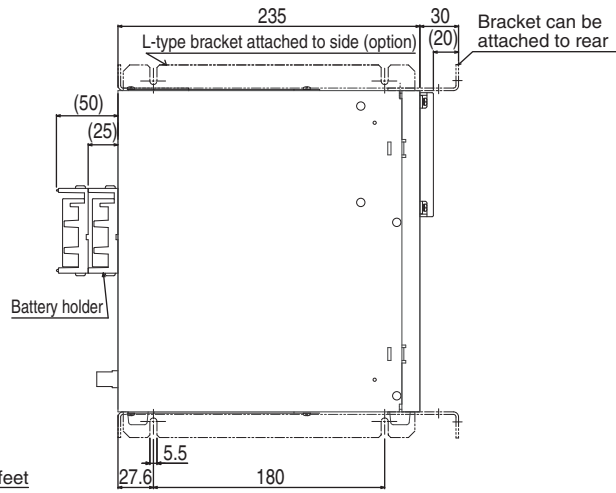

Rear view

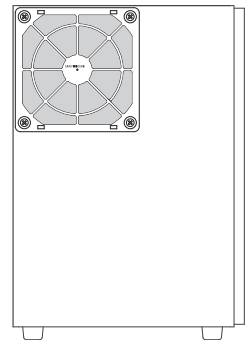

Bottom view

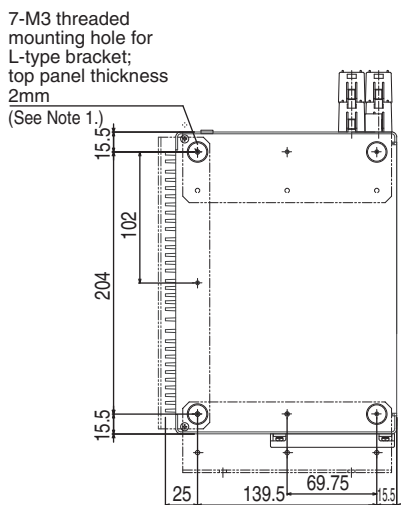

Note 1: When installing this controller using the supplied L-type brackets, remove the rubber feet on the bottom plate.

YRC with RGU2 option installed

Top view

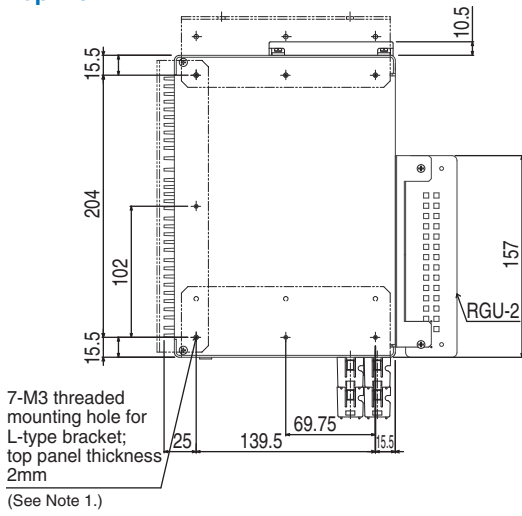

Front view

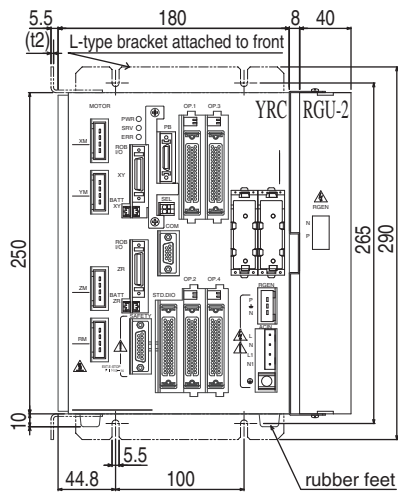

Side view

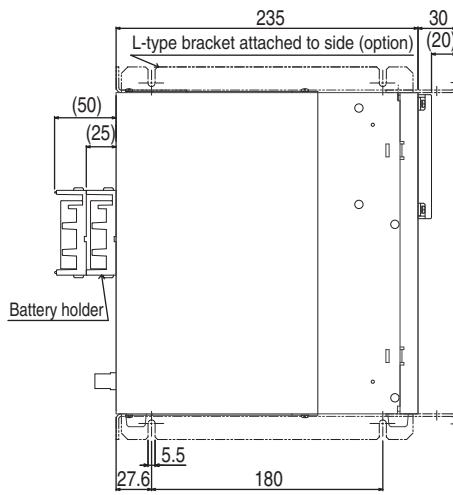

Rear view

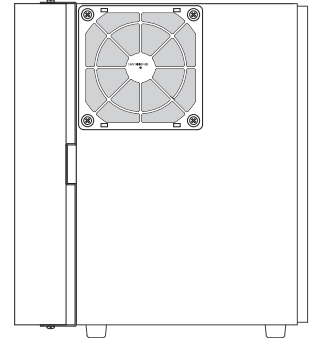

Bottom view

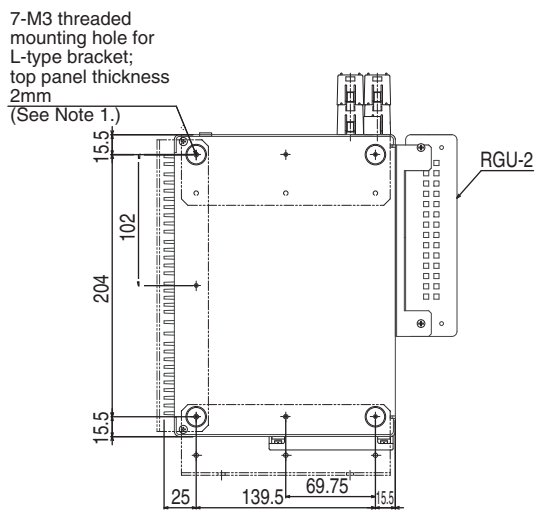

YRC with RGU3 option installed

Top view

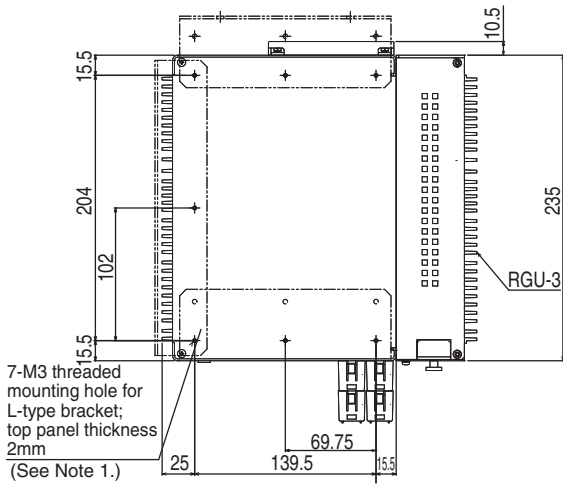

Front view

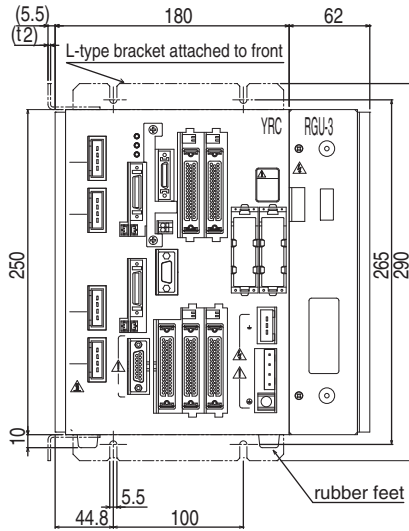

Side view

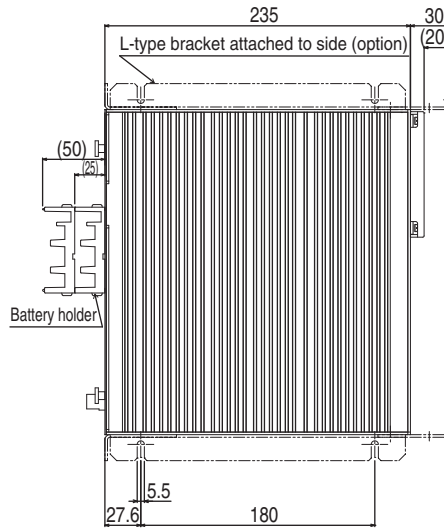

Rear view

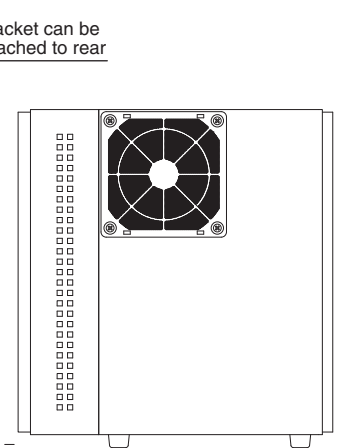

Bottom view

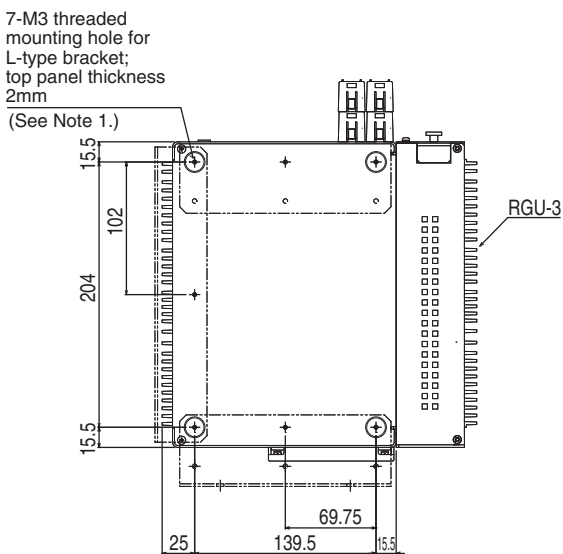

R6YXP250 DUST-PROOF & DRIP-PROOF TYPE

Specifications

	X axis	Y axis	Z axis	R axis
Reach (mm)	250			
Maximum payload (kg)	3			
Repeatability ^{*1} (XYZ:mm) (R:°)	+/-0.01			
Axis specifications	Arm length (mm)	125	150	150
	Rotation range (°)	+/-115	+/-130	----
Deceleration mechanism	Speed reducer	Harmonic drive	Harmonic drive	Ball screw
	Transmission method	Motor to speed reducer	Direct-coupled	Timing belt transmission
		Speed reducer to output	Direct-coupled	Timing belt transmission
AC servo motor output (W)	200	100	100	100
Maximum speed (XYZ:m/sec) (R:°/sec)	4			
Standard cycle time: with 2kg payload ^{*2} (sec)	0.54			
R axis allowable moment inertia ^{*3} (kgm ²)	0.05			
User wiring (sq x pcs)	0.2 x 10			
User tubing (Outer diameter)	Ø4 x 3			
Movement limit setting	1.Soft limit 2.Mechanical stopper (X, Y, Z axis)			
Robot cable length (m)	Standard: 3.5 Option: 5, 10			
Weight (kg) (Excluding robot cable)	15			

*1 This is the value at a constant ambient temperature. (X,Y axes)
 *2 When moving 25mm in vertical direction and 300mm in horizontal direction reciprocally.
 *3 There are limits to the setting of the acceleration coefficient.

Controller

Controller	Power consumption (VA)	Operating method
YRC	1000	Programming / I/O point trace / Remote command / Operation using RS-232C communication

Ordering information

Description	Model
SCARA Reach: 250mm, Vertical Stroke: 150mm, Max. payload: 3kg, Protection class: IP65	R6YXP250150YRC

Dimensions

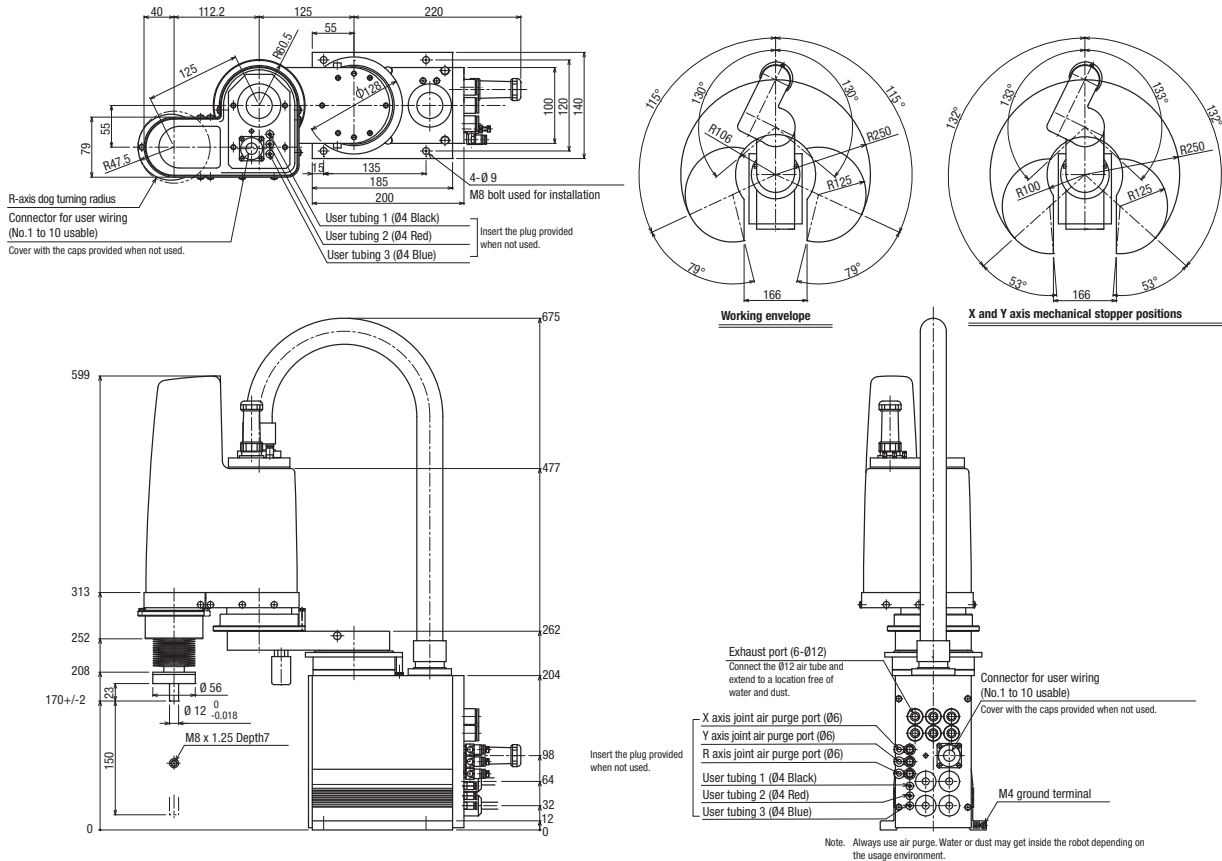

R6YXP350 DUST-PROOF & DRIP-PROOF TYPE

Specifications

		X axis	Y axis	Z axis	R axis
Reach (mm)		350			
Maximum payload (kg)		3			
Repeatability ¹ (XYZ:mm) (R:°)		+/-0.01		+/-0.01	+/-0.005
Axis specifications	Arm length (mm)	225	125	150	----
	Rotation range (°)	+/-115	+/-130	----	+/-360
Deceleration mechanism	Speed reducer	Harmonic drive	Harmonic drive	Ball screw	Harmonic drive
	Transmission method	Motor to speed reducer	Direct-coupled	Timing belt transmission	Timing belt transmission
		Speed reducer to output	Direct-coupled		
AC servo motor output (W)		200	100	100	100
Maximum speed (XYZ:m/sec) (R:°/sec)		5		1	1020
Standard cycle time: with 2kg payload ² (sec)		0.54			
R axis allowable moment inertia ³ (kgm ²)		0.05			
User wiring (sq x pcs)		0.2 x 10			
User tubing (Outer diameter)		Ø4 x 3			
Movement limit setting		1.Soft limit 2.Mechanical stopper (X, Y, Z axis)			
Robot cable length (m)		Standard: 3.5 Option: 5, 10			
Weight (kg) (Excluding robot cable)		15			

*1 This is the value at a constant ambient temperature. (X,Y axes)
 *2 When moving 25mm in vertical direction and 300mm in horizontal direction reciprocally.
 *3 There are limits to the setting of the acceleration coefficient.

Controller

Controller	Power consumption (VA)	Operating method
YRC	1000	Programming / I/O point trace / Remote command / Operation using RS-232C communication

Ordering information

Description	Model
SCARA Reach: 350mm, Vertical Stroke: 150mm, Max. payload: 3kg, Protection class: IP65	R6YXP350150YRC

Dimensions

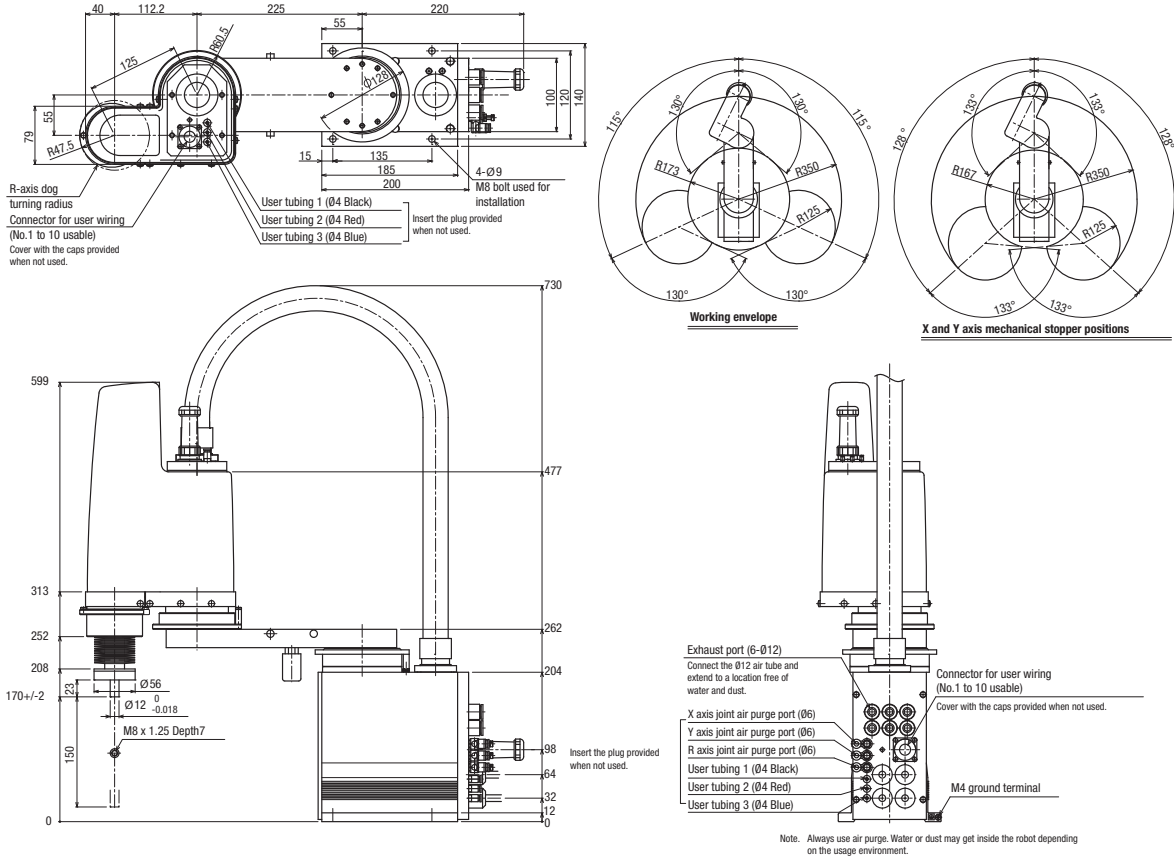

R6YXP400 DUST-PROOF & DRIP-PROOF TYPE

Specifications

	X axis	Y axis	Z axis	R axis
Reach (mm)	400			
Maximum payload (kg)	3			
Repeatability ^{*1} (XYZ:mm) (R:°)	+/-0.01		+/-0.01	+/-0.005
Axis specifications	Arm length (mm)	175	150	----
	Rotation range (°)	+/-115	+/-140	----
Deceleration mechanism	Speed reducer	Harmonic drive	Harmonic drive	Ball screw
	Transmission method	Motor to speed reducer	Direct-coupled	Timing belt transmission
		Speed reducer to output	Direct-coupled	Timing belt transmission
AC servo motor output (W)	200	100	100	100
Maximum speed (XYZ:m/sec) (R:°/sec)	6		1	1020
Standard cycle time: with 2kg payload ^{*2} (sec)	0.66			
R axis allowable moment inertia ^{*3} (kgm ²)	0.05			
User wiring (sq x pcs)	0.2 x 10			
User tubing (Outer diameter)	Ø4 x 3			
Movement limit setting	1.Soft limit 2.Mechanical stopper (X, Y, Z axis)			
Robot cable length (m)	Standard: 3.5 Option: 5, 10			
Weight (kg) (Excluding robot cable)	15			

*1 This is the value at a constant ambient temperature. (X,Y axes)
 *2 When moving 25mm in vertical direction and 300mm in horizontal direction reciprocally.
 *3 There are limits to the setting of the acceleration coefficient.

Controller

Controller	Power consumption (VA)	Operating method
YRC	1000	Programming / I/O point trace / Remote command / Operation using RS-232C communication

Ordering information

Description	Model
SCARA Reach: 400mm, Vertical Stroke: 150mm, Max. payload: 3kg, Protection class: IP65	R6YXP400150YRC

Dimensions

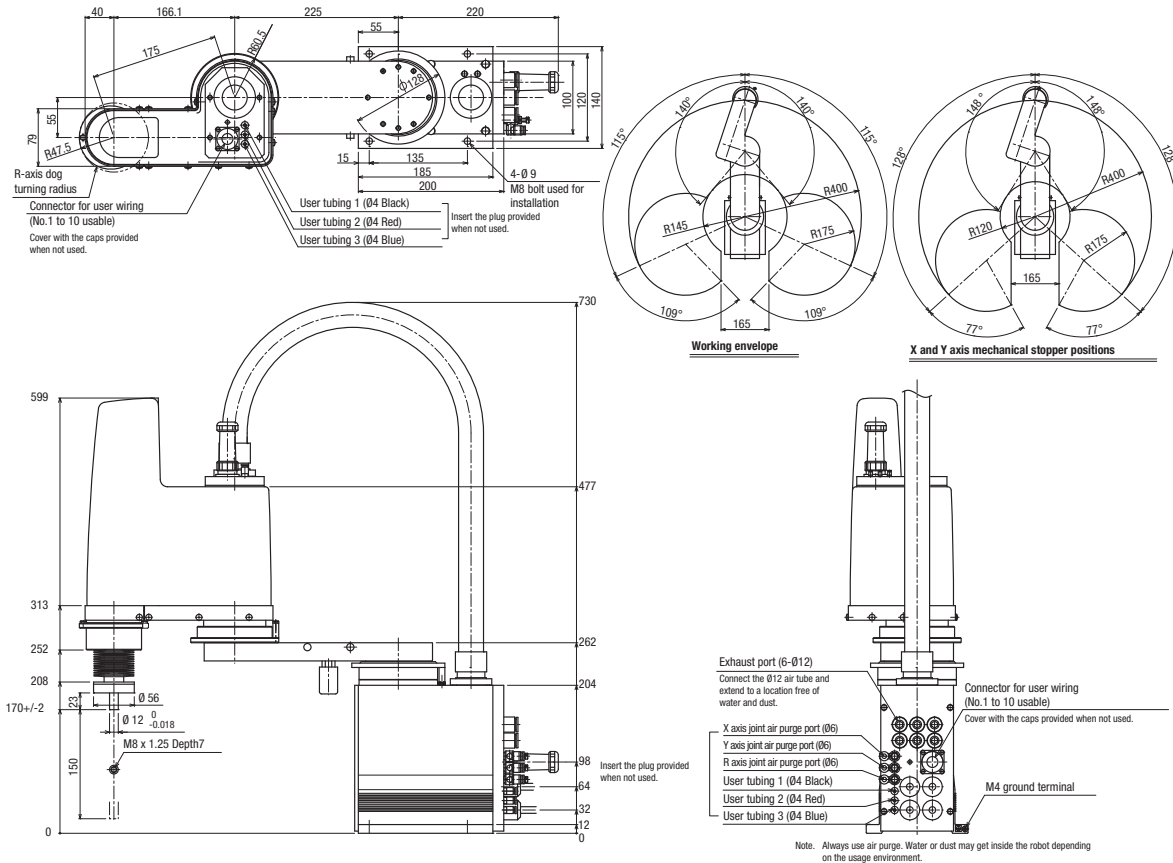

R6YXP500 DUST-PROOF & DRIP-PROOF TYPE

Specifications

		X axis	Y axis	Z axis	R axis
Reach (mm)		500			
Maximum payload (kg)		10			
Repeatability ^{*1} (XYZ:mm) (R:°)		+/-0.02		+/-0.01	+/-0.005
Axis specifications	Arm length (mm)	250	250	200	300
	Rotation range (°)	+/-120	+/-145	----	+/-360
Deceleration mechanism	Speed reducer	Harmonic drive	Harmonic drive	Ball screw	Harmonic drive
	Transmission method	Motor to speed reducer	Direct-coupled		Timing belt transmission
		Speed reducer to output	Direct-coupled		
AC servo motor output (W)		400	200	200	100
Maximum speed (XYZ:m/sec) (R:°/sec)		4.9		1.7	876
Standard cycle time: with 2kg payload ^{*2} (sec)		0.53			
R axis allowable moment inertia ^{*3} (kgm ²)		0.12			
User wiring (sq x pcs)		0.2 x 20			
User tubing (Outer diameter)		Ø6 x 3			
Movement limit setting		1.Soft limit 2.Mechanical stopper (X, Y, Z axis)			
Robot cable length (m)		Standard: 3.5 Option: 5, 10			
Weight (kg) (Excluding robot cable)		30			

- *1 This is the value at a constant ambient temperature. (X,Y axes)
- *2 When moving 25mm in vertical direction and 300mm in horizontal direction reciprocally.
- *3 There are limits to the setting of the acceleration coefficient.

Controller

Controller	Power consumption (VA)	Operating method
YRC	1500	Programming / I/O point trace / Remote command / Operation using RS-232C communication

Ordering information

Description	Model
SCARA Reach: 500mm, Vertical Stroke: 200mm, Max. payload: 10kg, Protection class: IP65	R6YXP500200YRC
SCARA Reach: 500mm, Vertical Stroke: 300mm, Max. payload: 10kg, Protection class: IP65	R6YXP500300YRC

Dimensions

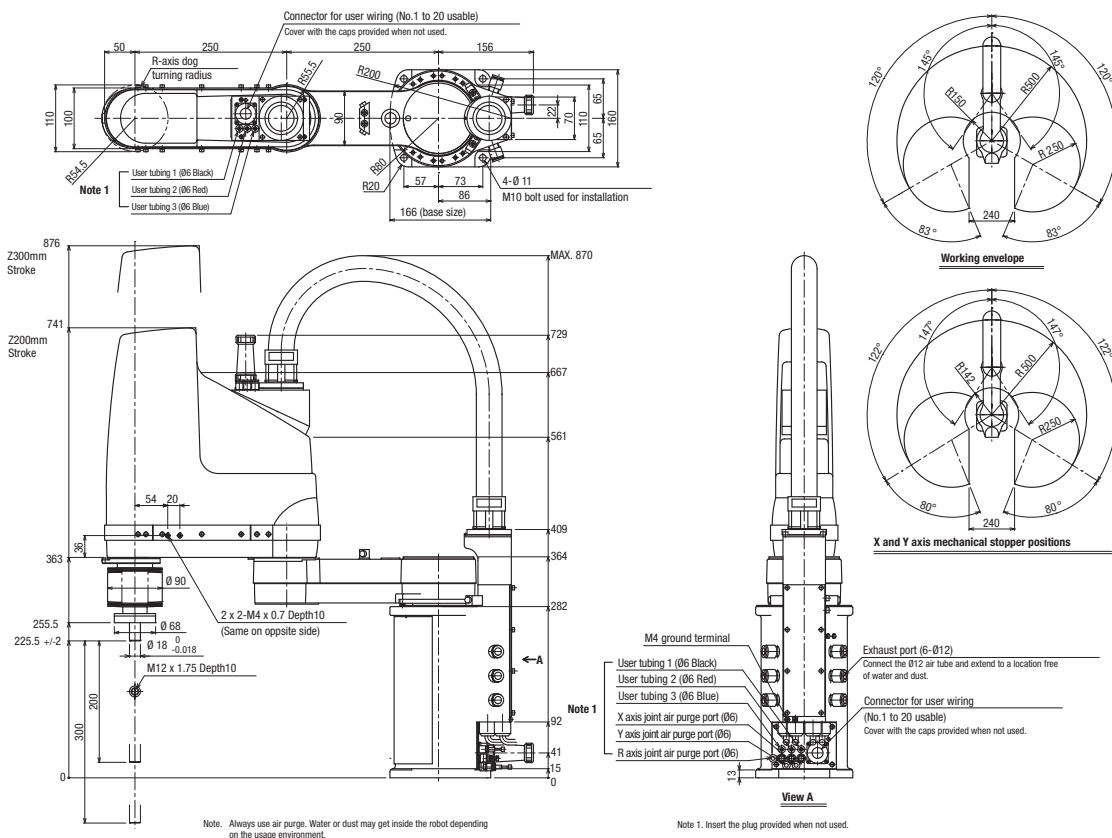

R6YXP700 DUST-PROOF & DRIP-PROOF TYPE

Specifications

		X axis	Y axis	Z axis	R axis
Reach (mm)		700			
Maximum payload (kg)		20			
Repeatability ¹ (XYZ:mm) (R:°)		+/-0.02		+/-0.01	+/-0.005
Axis specifications	Arm length (mm)	350	350	200	400
	Rotation range (°)	+/-120	+/-145	----	+/-360
Deceleration mechanism	Speed reducer	Harmonic drive	Harmonic drive	Ball screw	Harmonic drive
	Transmission method	Motor to speed reducer	Direct-coupled	Timing belt transmission	Timing belt transmission
		Speed reducer to output	Direct-coupled		
AC servo motor output (W)		800	400	400	200
Maximum speed (XYZ:m/sec) (R:°/sec)		6.7		1.7	600
Standard cycle time: with 2kg payload ² (sec)		0.57			
R axis allowable moment inertia ³ (kgm ²)		0.32			
User wiring (sq x pcs)		0.2 x 20			
User tubing (Outer diameter)		Ø6 x 3			
Movement limit setting		1.Soft limit 2.Mechanical stopper (X, Y, Z axis)			
Robot cable length (m)		Standard: 3.5 Option: 5, 10			
Weight (kg) (Excluding robot cable)		56			

- *1 This is the value at a constant ambient temperature. (X, Y axes)
- *2 When moving 25mm in vertical direction and 300mm in horizontal direction reciprocally.
- *3 There are limits to the setting of the acceleration coefficient.

Controller

Controller	Power consumption (VA)	Operating method
YRC	2000	Programming / I/O point trace / Remote command / Operation using RS-232C communication

Ordering information

Description	Model
SCARA Reach: 700mm, Vertical Stroke: 200mm, Max. payload: 20kg, Protection class: IP65	R6YXP700200YRC
SCARA Reach: 700mm, Vertical Stroke: 400mm, Max. payload: 20kg, Protection class: IP65	R6YXP700400YRC

Dimensions

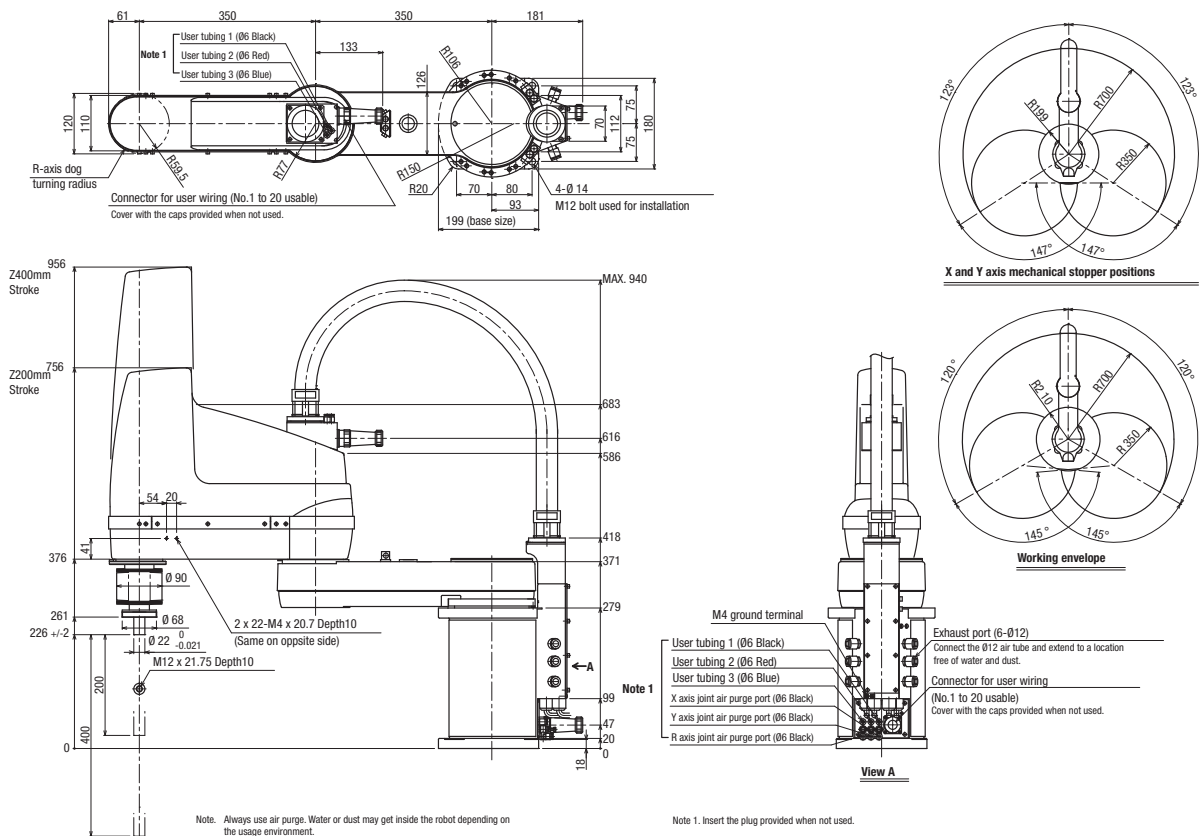

R6YXP800 DUST-PROOF & DRIP-PROOF TYPE

Specifications

	X axis	Y axis	Z axis	R axis
Reach (mm)	800			
Maximum payload (kg)	20			
Repeatability ^{*1} (XYZ:mm) (R:°)	+/-0.02		+/-0.01	+/-0.005
Axis specifications	Arm length (mm)	450	200	400
	Rotation range (°)	+/-120	+/-145	----
Deceleration mechanism	Speed reducer		Harmonic drive	Harmonic drive
	Transmission method	Motor to speed reducer	Direct-coupled	Timing belt transmission
		Speed reducer to output	Direct-coupled	Timing belt transmission
AC servo motor output (W)	800	400	400	200
Maximum speed (XYZ:m/sec) (R:°/sec)	7.3		1.7	600
Standard cycle time: with 2kg payload ^{*2} (sec)	0.57			
R axis allowable moment inertia ^{*3} (kgm ²)	0.32			
User wiring (sq x pcs)	0.2 x 20			
User tubing (Outer diameter)	Ø6 x 3			
Movement limit setting	1.Soft limit 2.Mechanical stopper (X, Y, Z axis)			
Robot cable length (m)	Standard: 3.5 Option: 5, 10			
Weight (kg) (Excluding robot cable)	57			

- *1 This is the value at a constant ambient temperature. (X,Y axes)
- *2 When moving 25mm in vertical direction and 300mm in horizontal direction reciprocally.
- *3 There are limits to the setting of the acceleration coefficient.

Controller

Controller	Power consumption (VA)	Operating method
YRC	2000	Programming / I/O point trace / Remote command / Operation using RS-232C communication

Ordering information

Description	Model
SCARA Reach: 800mm, Vertical Stroke: 200mm, Max. payload: 20kg, Protection class: IP65	R6YXP800200YRC
SCARA Reach: 800mm, Vertical Stroke: 400mm, Max. payload: 20kg, Protection class: IP65	R6YXP800400YRC

Dimensions

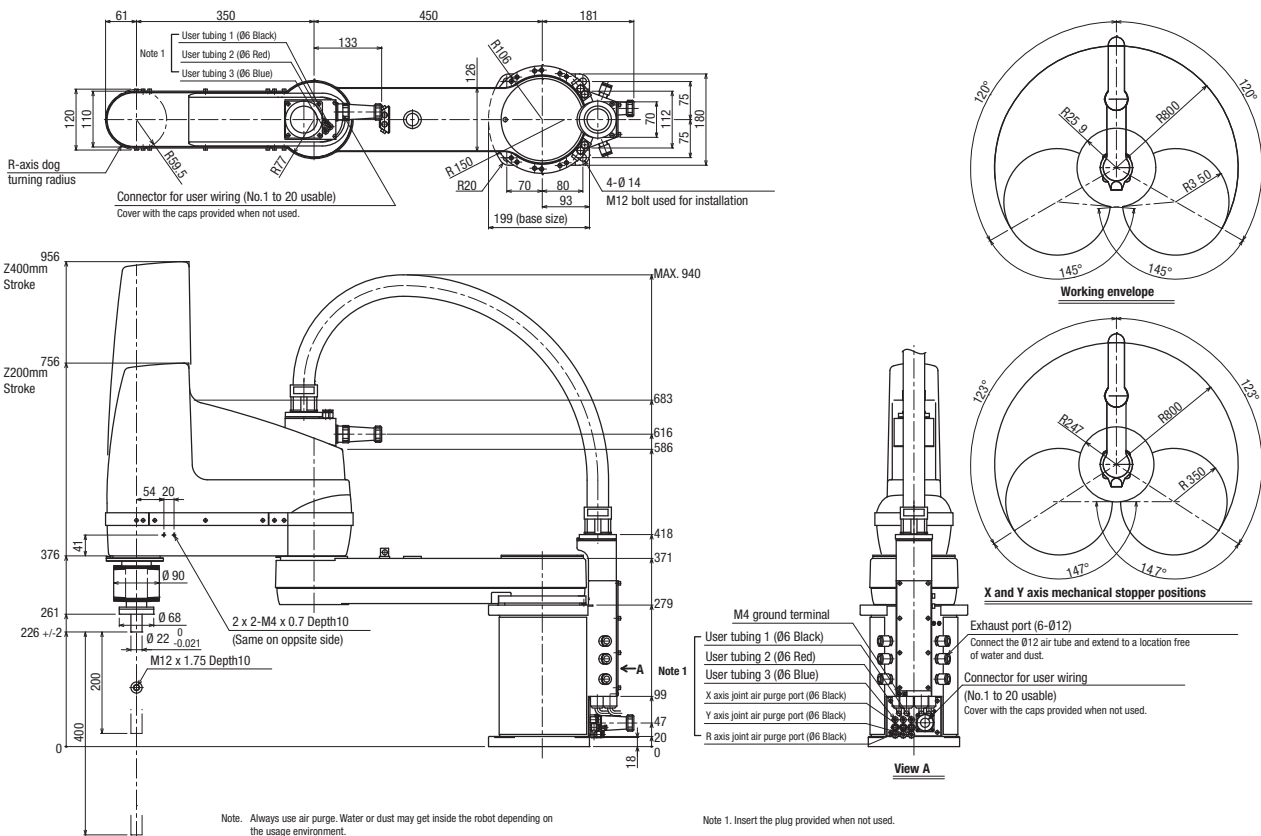

R6YXP1000 DUST-PROOF & DRIP-PROOF TYPE

Specifications

		X axis	Y axis	Z axis	R axis
Reach (mm)		1000			
Maximum payload (kg)		20			
Repeatability ¹ (XYZ:mm) (R:°)		+/-0.02		+/-0.01	+/-0.005
Axis specifications	Arm length (mm)	550	450	200	400
	Rotation range (°)	+/-120	+/-145	----	+/-360
Deceleration mechanism	Speed reducer	Harmonic drive	Harmonic drive	Ball screw	Harmonic drive
	Transmission method	Motor to speed reducer	Direct-coupled		Timing belt transmission
		Speed reducer to output	Direct-coupled		
AC servo motor output (W)		800	400	400	200
Maximum speed (XYZ:m/sec) (R:°/sec)		8		1.7	600
Standard cycle time: with 2kg payload ² (sec)		0.6			
R axis allowable moment inertia ³ (kgm ²)		0.32			
User wiring (sq x pcs)		0.2 x 20			
User tubing (Outer diameter)		Ø6 x 3			
Movement limit setting		1.Soft limit 2.Mechanical stopper (X, Y, Z axis)			
Robot cable length (m)		Standard: 3.5 Option: 5, 10			
Weight (kg) (Excluding robot cable)		58			

*1 This is the value at a constant ambient temperature. (X,Y axes)
 *2 When moving 25mm in vertical direction and 300mm in horizontal direction reciprocally.
 *3 There are limits to the setting of the acceleration coefficient.

Controller

Controller	Power consumption (VA)	Operating method
YRC	2000	Programming / I/O point trace / Remote command / Operation using RS-232C communication

Ordering information

Description	Model
SCARA Reach: 1000mm, Vertical Stroke: 200mm, Max. payload: 20kg, Protection class: IP65	R6YXP1000200YRC
SCARA Reach: 1000mm, Vertical Stroke: 400mm, Max. payload: 20kg, Protection class: IP65	R6YXP1000400YRC

Dimensions

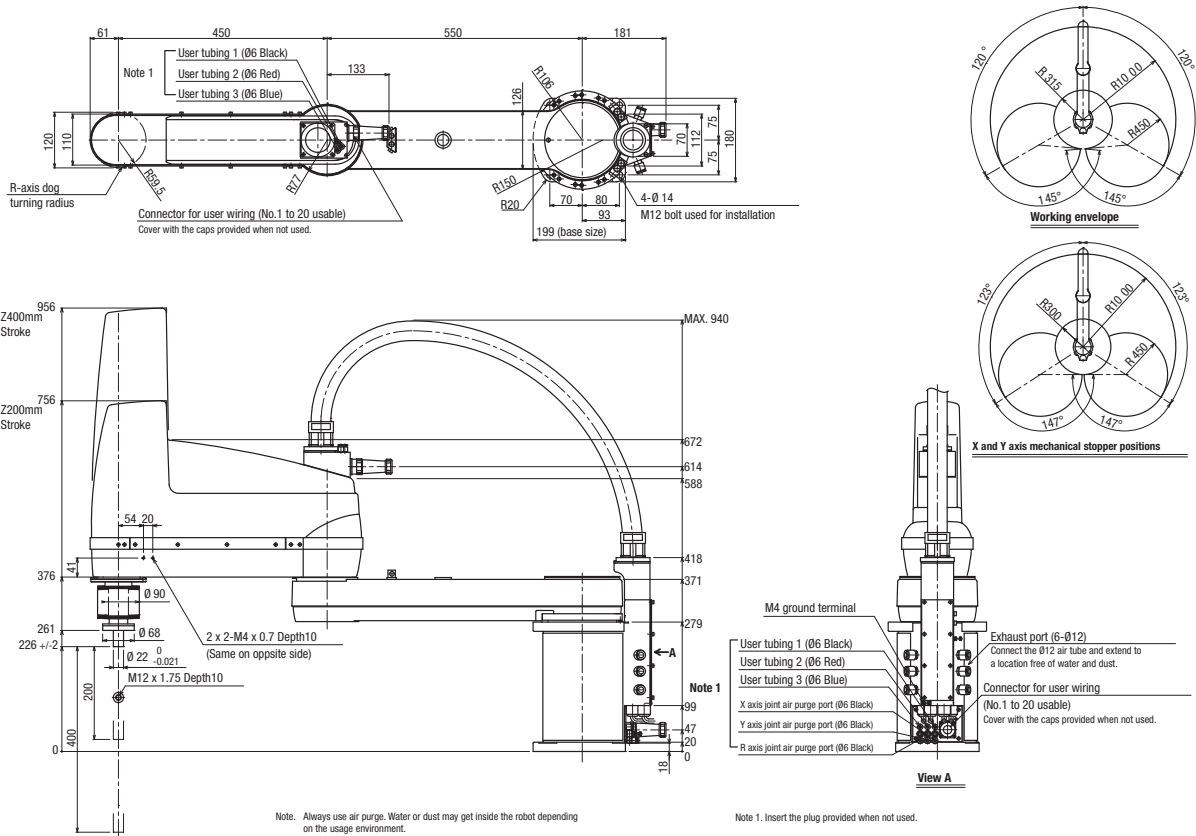

SCARA Robots Dust-proof & drip-proof type

Ordering information

	Series	Reach (mm)	Z-axis stroke (mm)	Payload (kg)	Robot item code	RGU	Robot cable length (m)	Cable item code	Detachable robot cable
R6Y	XP	250	150	3	R6YXP250150YRC	N.A.	3.5	R6YACCX003XP	N.A.
							5.0	R6YACCX005XP	N.A.
							10.0	R6YACCX010XP	N.A.
	XP	350	150	3	R6YXP350150YRC	N.A.	3.5	R6YACCX003XP	N.A.
							5.0	R6YACCX005XP	N.A.
							10.0	R6YACCX010XP	N.A.
	XP	400	150	3	R6YXP400150YRC	N.A.	3.5	R6YACCX003XP	N.A.
							5.0	R6YACCX005XP	N.A.
							10.0	R6YACCX010XP	N.A.
	XP	500	200	10	R6YXP500200YRC	RGU2	3.5	R6YACCX003XP	N.A.
							5.0	R6YACCX005XP	N.A.
							10.0	R6YACCX010XP	N.A.
			300	10	R6YXP500300YRC	RGU2	3.5	R6YACCX003XP	N.A.
							5.0	R6YACCX005XP	N.A.
							10.0	R6YACCX010XP	N.A.
	XP	600	200	10	R6YXP600200YRC	RGU2	3.5	R6YACCX003XP	N.A.
							5.0	R6YACCX005XP	N.A.
							10.0	R6YACCX010XP	N.A.
			300	10	R6YXP600300YRC	RGU2	3.5	R6YACCX003XP	N.A.
							5.0	R6YACCX005XP	N.A.
							10.0	R6YACCX010XP	N.A.
	XP	700	200	20	R6YXP700200YRC	RGU2	3.5	R6YACCX003XP	N.A.
							5.0	R6YACCX005XP	N.A.
							10.0	R6YACCX010XP	N.A.
			400	20	R6YXP700400YRC	RGU2	3.5	R6YACCX003XP	N.A.
							5.0	R6YACCX005XP	N.A.
							10.0	R6YACCX010XP	N.A.
	XP	800	200	20	R6YXP800200YRC	RGU2	3.5	R6YACCX003XP	N.A.
							5.0	R6YACCX005XP	N.A.
							10.0	R6YACCX010XP	N.A.
400			20	R6YXP800400YRC	RGU2	3.5	R6YACCX003XP	N.A.	
						5.0	R6YACCX005XP	N.A.	
						10.0	R6YACCX010XP	N.A.	
XP	1000	200	20	R6YXP1000200YRC	RGU2	3.5	R6YACCX003XP	N.A.	
						5.0	R6YACCX005XP	N.A.	
						10.0	R6YACCX010XP	N.A.	
		400	20	R6YXP1000400YRC	RGU2	3.5	R6YACCX003XP	N.A.	
						5.0	R6YACCX005XP	N.A.	
						10.0	R6YACCX010XP	N.A.	

ALL DIMENSIONS SHOWN ARE IN MILLIMETERS.
 To convert millimeters into inches, multiply by 0.03937. To convert grams into ounces, multiply by 0.03527.