

Grid Connect Photovoltaic Inverter KP100L-OD-□□

Quick Installation Guideline

Note: Dec, 2010

KP100L does not have the compatibility with thin-film module at this moment.
The compatibility is under evaluation.

OMRON

Part number 2132254-1 C

Introduction

Thank you for choosing the KP100L Grid Connect Photovoltaic Inverter (hereinafter called "the KP100L"). This Quick Installation Guideline (hereinafter called "QIG") describes essential information regarding installation of the KP100L.

The KP100L is designed for use in Grid Connect Solar Systems. The installation must always be carried out by qualified personnel with knowledge of electrical systems and according to national standards for electrical installations.

The software and the protective functions are not accessible and/or changeable to the user.

- This QIG is intended for: Users and Installers of the KP100L
- Read this QIG carefully and make sure that you understand it well to ensure that you are using the KP100L correctly.
- Keep this QIG in a safe location so that it is available for reference when required.
- For more detail description such as function, performance, and usage of the KP100L, refer to the User's manual of the KP100L.

Read and Understand This QIG

Read and understand this QIG before using the KP100L. Please consult your OMRON representative if you have any questions or comments.

Warranty and Limitations of Liability

WARRANTY
<p>OMRON's exclusive warranty is that the products are free from defects in materials and workmanship for a period of five years (or other period if specified) from date of sale by OMRON.</p> <p>OMRON MAKES NO WARRANTY OR REPRESENTATION, EXPRESS OR IMPLIED, REGARDING NON-INFRINGEMENT, MERCHANTABILITY, OR FITNESS FOR PARTICULAR PURPOSE OF THE PRODUCTS. ANY BUYER OR USER ACKNOWLEDGES THAT THE BUYER OR USER ALONE HAS DETERMINED THAT THE PRODUCTS WILL SUITABLY MEET THE REQUIREMENTS OF THEIR INTENDED USE. OMRON DISCLAIMS ALL OTHER WARRANTIES, EXPRESS OR IMPLIED.</p>

LIMITATIONS OF LIABILITY
<p>OMRON SHALL NOT BE RESPONSIBLE FOR SPECIAL, INDIRECT, OR CONSEQUENTIAL DAMAGES, LOSS OF PROFITS OR COMMERCIAL LOSS IN ANY WAY CONNECTED WITH THE PRODUCTS, WHETHER SUCH CLAIM IS BASED ON CONTRACT, WARRANTY, NEGLIGENCE, OR STRICT LIABILITY.</p> <p>In no event shall the responsibility of OMRON for any act exceed the individual price of the product on which liability is asserted.</p> <p>IN NO EVENT SHALL OMRON BE RESPONSIBLE FOR WARRANTY, REPAIR, OR OTHER CLAIMS REGARDING THE PRODUCTS UNLESS OMRON'S ANALYSIS CONFIRMS THAT THE PRODUCTS WERE PROPERLY HANDLED, STORED, INSTALLED, AND MAINTAINED AND NOT SUBJECT TO CONTAMINATION, ABUSE, MISUSE, OR INAPPROPRIATE MODIFICATION OR REPAIR.</p>

Application Considerations

SUITABILITY FOR USE
<p>OMRON shall not be responsible for conformity with any standards, codes, or regulations that apply to the combination of products in the customer's application or use of the products.</p> <p>At the customer's request, OMRON will provide applicable third party certification documents identifying ratings and limitations of use that apply to the products. This information by itself is not sufficient for a complete determination of the suitability of the products in combination with the end product, machine, system, or other application or use.</p> <p>The following are some examples of applications for which particular attention must be given. This is not intended to be an exhaustive list of all possible uses of the products, nor is it intended to imply that the uses listed may be suitable for the products:</p> <ul style="list-style-type: none"> • Uses involving potential chemical contamination or electrical interference, or conditions or uses not described in this manual. • Nuclear energy control systems, combustion systems, railroad systems, aviation systems, medical equipment, amusement machines, vehicles, safety equipment, and installations subject to separate industry or government regulations. • Systems, machines, and equipment that could present a risk to life or property. <p>Please know and observe all prohibitions of use applicable to the products.</p> <p>NEVER USE THE PRODUCTS FOR AN APPLICATION INVOLVING SERIOUS RISK TO LIFE OR PROPERTY WITHOUT ENSURING THAT THE SYSTEM AS A WHOLE HAS BEEN DESIGNED TO ADDRESS THE RISKS, AND THAT THE OMRON PRODUCTS ARE PROPERLY RATED AND INSTALLED FOR THE INTENDED USE WITHIN THE OVERALL EQUIPMENT OR SYSTEM.</p>

Disclaimers

PERFORMANCE DATA

Performance data given in this manual is provided as a guide for the user in determining suitability and does not constitute a warranty. It may represent the result of OMRON's test conditions, and the users must correlate it to actual application requirements. Actual performance is subject to the OMRON Warranty and Limitations of Liability.

CHANGE IN SPECIFICATIONS

Product specifications and accessories may be changed at any time based on improvements and other reasons. Consult with your OMRON representative at any time to confirm actual specifications of purchased product.

DIMENSIONS AND WEIGHTS

Dimensions and weights are nominal and are not to be used for manufacturing purposes, even when tolerances are shown.

ERRORS AND OMISSIONS

The information in this manual has been carefully checked and is believed to be accurate; however, no responsibility is assumed for clerical, typographical, or proofreading errors, or omissions.

PROGRAMMABLE PRODUCTS

OMRON shall not be responsible for the user's programming of a programmable product, or any consequence thereof.

COPYRIGHT AND COPY PERMISSION

This document shall not be copied for sales or promotions without permission. This document is protected by copyright and is intended solely for use in conjunction with the product. Please notify us before copying or reproducing this document in any manner, for any other purpose. If copying or transmitting this document to another, please copy or transmit it in its entirety.

Safety Precautions

■ Indications and Meanings of Safety Information

In this user's QIG, the following precautions and signal words are used to provide information to ensure the safe use of the KP100L.

The information provided here is vital to safety. Strictly observe the precautions provided.

■ Meanings of Signal Words

 WARNING	Indicates a potentially hazardous situation which, if not avoided, will result in minor or moderate injury, or may result in serious injury or death. Additionally there may be significant property damage.
--	--

 CAUTION	Indicates a potentially hazardous situation which, if not avoided, may result in minor or moderate injury or in property damage.
--	--

■ Meanings of Alert Symbols

	General Used for general CAUTION, WARNING, or DANGER precautions for which there is no specified symbol.
--	---

	High temperature precaution Used to warn of the risk of minor injury caused by high temperatures.
---	--

	General Used for general prohibitions for which there is no specific symbol.
---	---

	General Used for general mandatory action precautions for which there is no specified symbol.
---	--





	Electric shock precaution Used to warn of the risk of electric shock under specific conditions.
---	--





	Always ground Used to instruct the user to always connect the ground wire when using a device equipped with a safety ground terminal.
---	--

■ Alert Symbols in This Document

Important user information:





Observe the following warnings and cautions when using the KP100L.





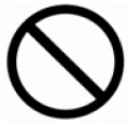

 WARNING	
	<p>Significant property damage may possibly occur. Do not use the product in other country than the designated country.</p>
	<p>Functional lesion by injury and fire damage may possibly occur. Do not remove the MC cap on the back of the product when you exchange the FAN Assembly.</p>
	<p>Ask to the store where you purchased the product or to an authorized service person when disposing of the product.</p>
	<p>Injury by electric shock may possibly occur. Read this manual before installation, operating and maintenance of the product, and follow the instructions carefully.</p>
	<p>Injury by electric shock may possibly occur. Do not open the cover foreside R during energizing.</p>
	<p>Significant injury by electric shock may possibly occur. Do not touch the terminal of the MC connector. Do not remove the MC connector excluding the instruction of this manual.</p>

 CAUTION	
	<p>Burn injury may occasionally occur. Do not touch the upper part of the product while operating or immediately after having turned off power.</p>
	<p>Fire damage or functional lesion of internal part may occasionally occur. Do not obstruct the heat sink or place any objects within 200mm of the heat sink.</p>
	<p>Fire damage and malfunction may occasionally occur. Do not use the product that dropped or applied a strong impact.</p>
	<p>Functional lesion by fire damage may occasionally occur. Do not unfasten of the MC connector and the cable clamp during operating.</p>
	<p>The limitation of the output electric power by the ventilation trouble may occasionally occur. Clean the top and bottom of the heat sink regularly.</p>
	<p>Injury or fire by electric shock may possibly occur. Do not open, disassemble, modify, or repair the cover front and the cover foreside L during operating</p>

Important installer information:

Observe the following warnings and cautions when installing the KP100L.

 WARNING	
	<p>Significant property damage may possibly occur. Do not use the product in other country than the designated country.</p>
	<p>Significant property damage may possibly occur. Do not use the product with a mistake of the country setting.</p>
	<p>Functional lesion by injury and fire damage may possibly occur. Do not remove the MC cap on the back of the product when you exchange the FAN Assembly.</p>
	<p>Significant property damage may possibly occur. Execute the installation by a person who has the qualification that authorized by the electric power company in the region.</p>
	<p>Electric shock and significant property damage may possibly occur. Do a correct connection after confirming the polarity of the cable from the solar modules and from the grid.</p>
	<p>Fire by loose connection of AC terminal block may possibly occur. Confirm there is no looseness in the screw of the AC terminal block during the maintenance.</p>
	<p>When using the product by the state that tightening the screw of AC terminal block is insufficient, fire by loose connection may possibly occur. Insert the electric cable in the inner of AC terminal block by using special Rod terminal and crimping pliers, and tighten the screw by tightening torque of 1.2-1.5N·m.</p>
	<p>Fire by loose connection of the MC connector may possibly occur. Use the specialized tool for the crimping process of the MC connector. Insert the MC connector surely until locking.</p>
	<p>Injury by electric shock may possibly occur. Read this manual before installation, operating and maintenance of the product, and follow the instructions carefully.</p>
	<p>Injury or functional lesion by electric shock or burn injury may possibly occur. Do not install the product in places that child's hand reaches.</p>
	<p>Injury by electric shock may possibly occur. Do not open the cover foreside R during energizing.</p>
	<p>Significant injury by electric shock may possibly occur. Do not touch the terminal of the MC connector. Do not remove the MC connector excluding the instruction of this manual.</p>
	<p>Significant injury by electric shock may possibly occur. Do not open the cover foreside R and not touch the MC connector for three minutes after turning OFF the breaker of the grid side and the solar module side.</p>
	<p>Injury by electric shock may possibly occur. Connect the PE cable to the earth.</p>

 CAUTION	
	Burn injury may occasionally occur. Do not touch the upper part of the product while operating or immediately after having turned off power.
	Fire damage or functional lesion of internal part may occasionally occur. Do not obstruct the heat sink or place any objects within 200mm of the heat sink.
	Fire damage and malfunction may occasionally occur. Do not use the product that dropped or applied a strong impact.
	Breakdown of DC input plug may occasionally occur. Do not put the product on ground with it had the DC input plug side below.
	Injury may occasionally occur. Transport and place the product carefully by two persons or more.
	Functional lesion by the fall of the product may occasionally occur. Use the installation parts and materials that are included in the product.
	Functional lesion by fire damage of terminal may occasionally occur. Detach the MC connector by the state that turns off the breaker of the solar modules side. In the state that the current flows, inserting and removing of the MC connector is not allowed.
	Break down or deterioration of the solar modules may occasionally occur. Install the breaker between the transformer and the KP100L when you connect the transformer. Connect the Neutral of the transformer to the earth.
	Breakdown of internal part by static electricity may occasionally occur. Execute wiring after discharging static electricity.
	Functional lesion by fire damage may occasionally occur. Confirm there is no looseness of the AC cable clamp, the communication cable clamp and the AUX cable clamp. Confirm the MC connector is locked.
	Injury or fire by electric shock may possibly occur. Do not open, disassemble, modify, or repair the cover front and the cover foreside L during operating
	Human hazard by electric shock or property damage by fire damage may occasionally occur. Mount the enclosed MC caps onto MC connector that is not used.
	Electric shock or fire by the foreign body going into the product may occasionally occur. Prevent the foreign body from invading from the cover foreside R when wiring.
	Functional lesion by injury and fire damage by the fall of the product may occasionally occur. Install the product in the location where the weight (41.5kg) of the product can be endured (the power of 176N·m torque per one screw can be endured).

Precautions for Safe Use

To use the product safely, what is executed or should be avoided is shown.

■ Installation

Put the space of 200mm or more between the following.

- Between the product and the ceiling or eave
- Between the product and the floor
- Between the product and right and left wall

When you install the multiple KP100L, put the space of 200mm or more on the side of each KP100L. Do not install the multiple KP100L vertically.

Do not install in the location where the product receives direct sunlight or rain when you install in outdoor.

Do not install the product in the home or near the place where the person works because the audible noise generates when the product is operating.

■ Transporting

Provide sufficient safety measures, such as scaffolding, to prevent danger during installation work.

■ Installation and Wiring

Make sure the following points when you install the product.

- 1) Use the accessories included with KP100L.
- 2) Make sure there is neither danger nor malfunction by the peripheral and the wire, etc. other than the accessory.
 - When wiring to the AC terminal block, do not insert two or more wires into one terminal.
 - Use the wire of the diameter that corresponds to the capacity of the Solar modules. Fire or smoke from fire may occur.
 - IP65 performance can not be provided, if you don't follow these instructions:
- 3) Use the cable of $\phi 18.5-20.5\text{mm}$ when you use the rubber bush of one hole for the AC cable clamp.
- 4) Use the five cables of $\phi 3.5-4.0\text{mm}$ when you use the rubber bush of five holes for the AC cable clamp.
- 5) Use the cable of $\phi 4\text{mm}$ for the communications cable and the AUX cable.
- 6) Tighten the cable clamp.
- 7) Tighten the screws of the cover foreside R by tightening torque 1.5-1.7 N·m.
- 8) Make sure the wire doesn't come off the terminal block after wiring the communication wire and the AUX wire to the terminal block.

■ Solar Module

- Do not connect the solar module that has an open-circuit voltage in excess of 850 VDC.
- Do not connect the solar module that requires earthing of negative or positive pole.

■ Breaker

- Use the breaker that corresponds to the capacity of the solar modules for the breaker of the Solar modules side.
- Use the 20A trip breaker with B or C or D trip characteristics for the breaker of the grid side.

■ Maintenance - Inspection

- Be sure to inspect install condition, wiring connection, before doing a trial operation.
- To secure the IP65 performance, execute the additional tightening of the cable clamp regularly.

Precautions for Correct Use

To prevent the adverse effect on the operation, what is executed or should be evaded is shown below.

■ Installation

- Install the product in a regulated direction.
- Do not install the product in the following places.
 - 1) Locations subject to intense temperature change.
 - 2) Locations subject to volatile, flammable, corrosive, or other toxic gas.
 - 3) Locations subject to vibration and large shocks.
 - 4) Locations subject to water vapor, oil vapor, or condensation.
 - 5) Locations where the product may be immersed in water.
 - 6) Locations subject to electric fields, direct sunlight, poor ventilation (ex. Narrow places where the ventilation would be obstructed or the ambient temperature conditions would be exceeded.).
 - 7) Locations subject to temperature and humidity conditions outside of the following ranges.
 - Temperature: -20 to 60°C
 - Humidity: 4 to 100%RH (Without condensation or freezing)
 - 8) Locations more than 2,000 m above sea level.
 - 9) Locations subject to saltwater spray, such as on oceangoing vessels or near a seacoast.
 - 10) Locations subject to falling snow, accumulated snow, or wind-blown snow.
Protect the product by building a protective roof when you install the product in the snowy region.
 - 11) Locations near highly combustible something or heat sources (stoves, heaters, boilers, etc.
 - 12) Locations subject to being damaged the wiring by animals or other factors.
Protect the wiring by, for example, placing wiring ducts.
 - 13) Locations subject to near the equipment (such as a radio or TV) that is likely to be affected by electric waves, or to near an antenna.

■ Use the Product

- Do not stand on the product or place any objects on the product.
- Serious human hazard by fire may possibly occur.
- Do not use the product in a flammable gas atmosphere (including flammable sprays such as pesticides).
- Electric shock or fire may occur. Ask an authorized service person or a qualified person with knowledge of electrical system when you install, add on, move or reinstall the product.

■ Surge protection

- Install the surge measures circuit corresponding to the output voltage
- and input voltage to protect the inverter from the lightning surge.
- To do a steady operation, install and use the product in places where the following situations are avoided.
 - 1) Locations where surge voltage of the grid is generated by influence of neighborhood facilities and equipment.
 - 2) Locations where the grid is unstable caused by influence of neighborhood facilities and equipment.
 - 3) In factory or the vicinity where the grid is unstable.
 - 4) Locations subject to noise that ungrounded consumer electronics generate.

■ Storage

- Store in locations where the temperature is within the range of -25 to 60°C
- (with no condensation or icing), and the humidity is 95 % maximum.
- Store in locations that is no more than 2,000 m above sea level.

1. Checking After Unpacking

■ Checking the Accessories

The follow items are included in the KP100L package. Check that all of the items shown in the package before you start the installation.

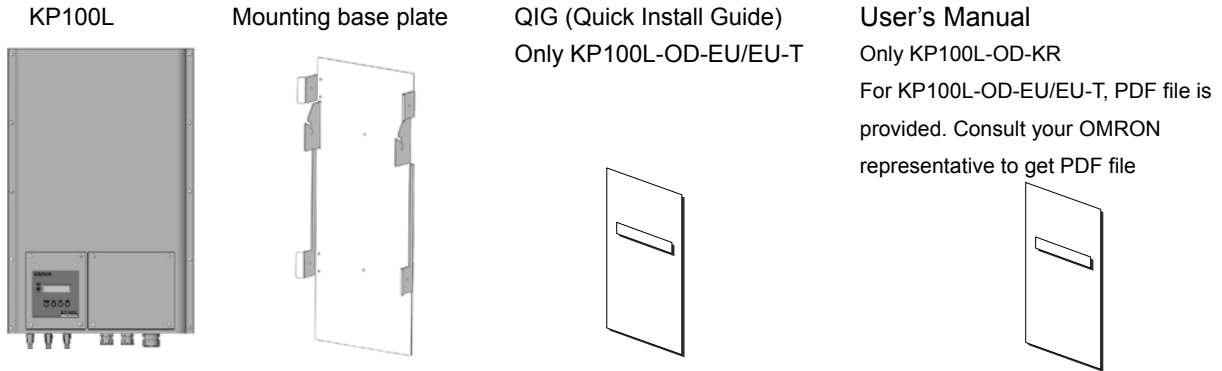

The complete set of Accessories

Items	Number	Note	
Mounting Screw	8	For installation of Mounting base plate	
Snap Bushing	8	Tool of assistance when screw is stopped to hard wall like concrete.	
M4 x 12mm Screw with plain washer and spring washer	5	For fixation of product set up in Mounting base plate (4 peaces are for mounting, a peace is for reserve)	
M4 x 6mm Screw with plain washer and spring washer	2	Spare screw to fix the cover foreside R	
Rubber Bush	1	For connection of AC cable	
	1	For connection of AC cable	
	2	Spare rubber bush For connection of AUX and communication	
MC Caps	2	Caps for MC connection (+) These are attached to KP100L.	
	2	Caps for MC connection (-) These are attached to KP100L.	

2. Typical System Configuration

The figure below shows the typical system configuration of the KP100L.

The equipments in AC and DC side are used depends on the design of the customer.

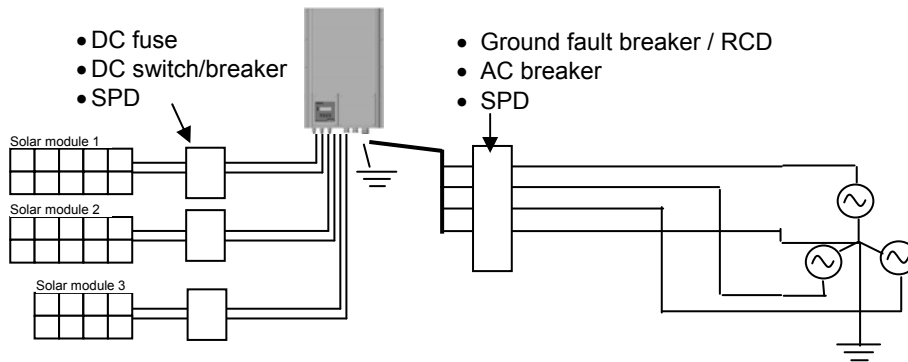

■ Applicable grid network

The KP100L is designed to operate with grid network system type TT, TN as shown in the figure below. If the KP100L is connected to the different type of grid network such as IT, it may be fault occur.

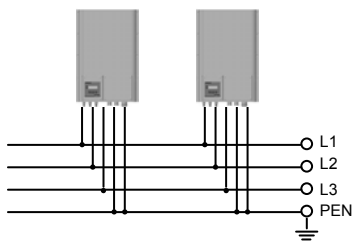

Connection with grid network type TN

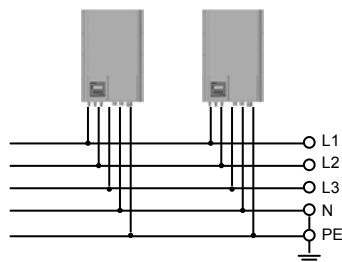

Connection with grid network type TT

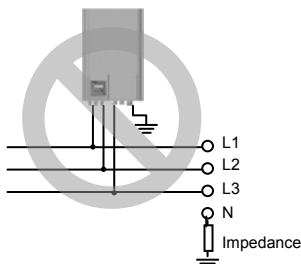

Connection with grid network type IT

2. Typical System Configuration

The KP100L is designed with grid network system type TT, TN. Then If you use transformer, connect the Neutral to the ground as shown in the figure below.

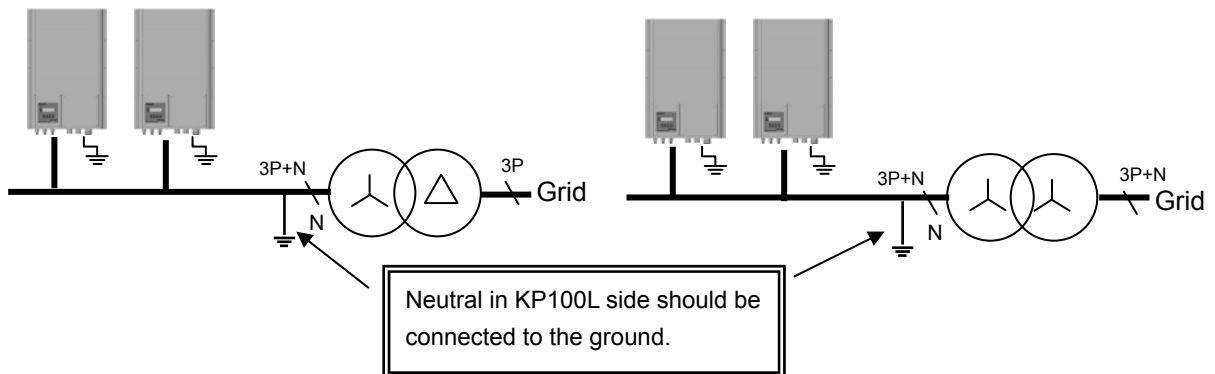

■ Applicable solar module

The KP100L is designed to control the voltage of negative pole on solar module as same voltage level as Neutral of grid as shown in figure below. This can be achieved by new inverter circuit (ZCC). As a result, the voltage of negative pole on solar module is approx. zero. According to this function, you can use the solar module which does not allow negative voltage on solar module.

Applicable type of solar module is shown in the table below.

Solar module manufacture requirement	Type of solar module	Applicable or not
(1) No requirement	Conventional silicon-based solar modules	KP100L can be used.
(2) No negative voltages on solar module	Some thin-film or silicon modules	Basically, KP100L can be used.
(3) Earthing of negative pole on solar module	Some thin-film or silicon modules	KP100L can not be used.
(4) No positive voltages on solar module	Specific solar module	KP100L can not be used.
(5) Earthing of positive pole on solar module	Specific solar module	KP100L can not be used.

Note: Dec, 2010

**KP100L does not have the compatibility with thin-film module at this moment.
The compatibility is under evaluation.**

3. Application information

■ DC side

DC switch / breaker

DC switch / circuit breaker is an obligatory prerequisite stipulated by DIN VDE 0100-712, the installation standard for PV systems in Germany. For safety point of view during working on an electrical device, it is necessary to disconnect from the energy supply. DC circuit breaker between the PV modules and the inverter is used. Select DC circuit breaker with rate current is larger than designed PV short circuit current on each DC input.

SPD (Surge Protective Device) in DC side

SPD (Surge protective device) is used to protect the inverter against lightning surge voltage.

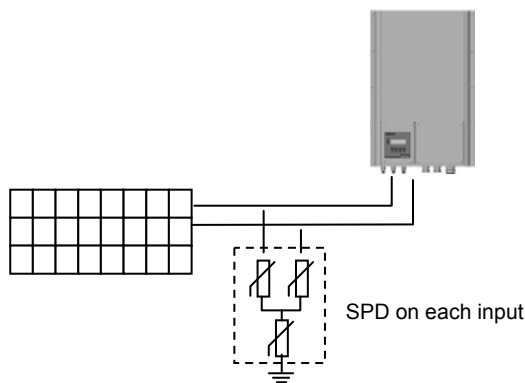

Example of SPD

- Class II
- PV voltage 1000 VDC
- Nominal discharge current (8/20us) I_n : 20 kA
- Maximum discharge current (8/20us) I_{max} : 40 kA
- Protection level: 4 kV

This is just example. Contact company of protection device for selection.

■ AC Grid side

AC breaker

For protection of AC over current, use a 20 A trip breaker with B or C or D trip characteristics.

If you use the transformer, install the breaker between the transformer and the KP100L as shown in the figure below.

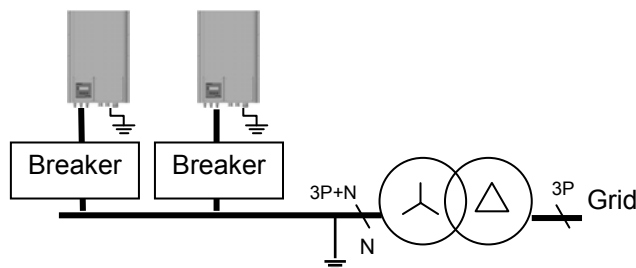

Ground fault breaker / RCD (Residual Current Device)

For KP100L, the use of RCDs type B is not indispensable and RCDs type A can be used. KP100L has built-in fault current protection function required in Germany standard of VDE V 0126-1-1:2006-02, so DC residual current can be detected and cannot flow to the grid.

Notice of selecting RCD

- The use of RCDs for each unit is recommended.
- $I_{\Delta n}$ (rated residual operating current of RCD) has to be selected according to the local regulations about the system configuration, and residual current caused by capacitive characteristic of cable and PV modules.
- In the systems which DC current detection of $I_{\Delta n} < 30\text{mA}$ is required, type B has to be used.
- KP100L has built-in fault current protection function but residual current is not zero, so the more KP100L installed units, the much residual current flows in the grid. When multiple KP100L are installed, downstream RCD(for KP100L) and upstream RCD has to be determined by consideration of increasing residual current.
- Ultimately, the selection of RCD depends on System Integrators' judgment. OMRON provide this information for selection of RCDs, but we are not responsible for the selection of RCD.

SPD in Grid side

SPD is used to protect the inverter against lightning surge voltage in AC line.

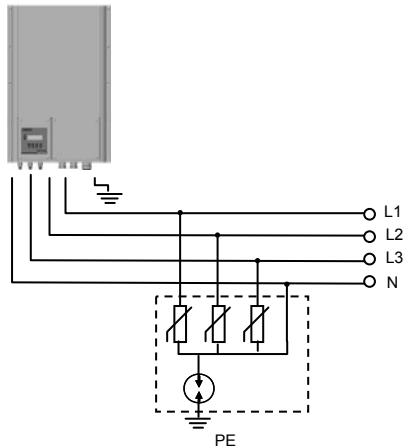

Example of SPD

- Class II
 - Nominal voltage 230/400 VAC
 - Nominal discharge current (8/20us) I_n : 20 kA
 - Maximum discharge current (8/20us) I_{max} : 40 kA
 - Protection level: 1.5 kV
- This is just example. Contact company of protection device for selection.

4. Installation

■ Dimensional Drawing

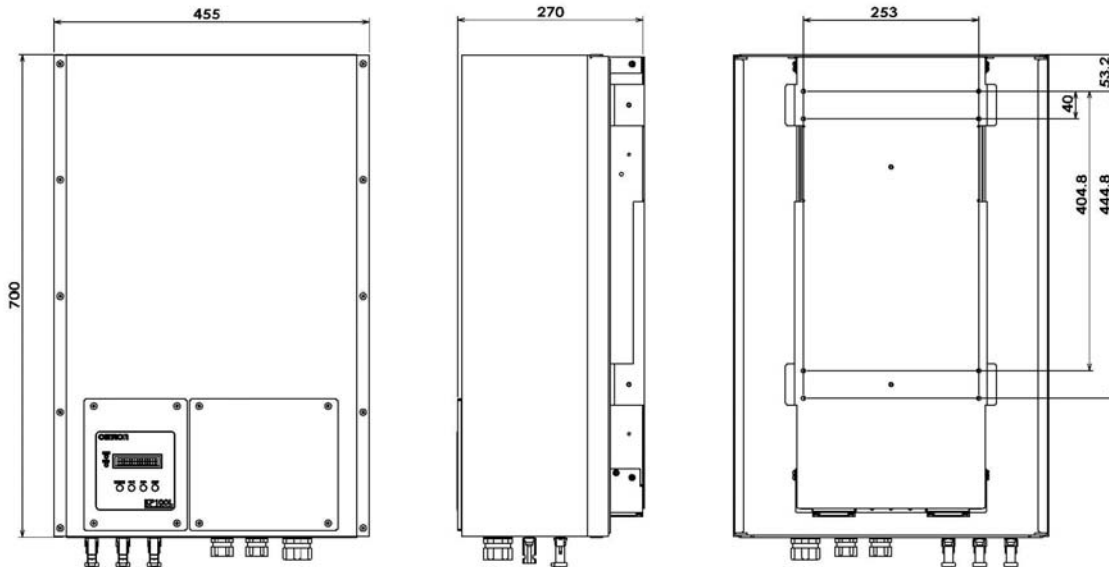

■ Installation Environment

- Leave specific space as shown in the figure below between the KP100L and the ceiling or eave, the floor or ground, and wall when you install the KP100L.
- When you install multiple Inverters, leave a space of 200mm the minimum to the side of the Inverter. Do not install multiple Inverters vertically.

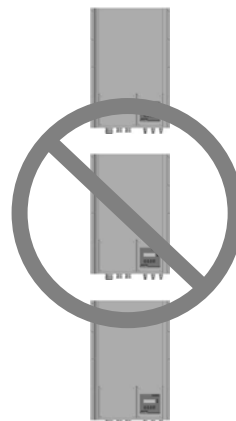
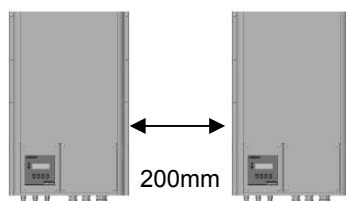
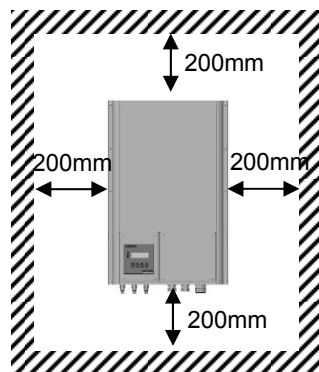



Mount Inverter Straight

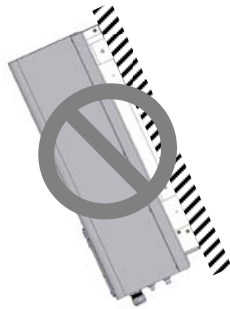

Never mount tilted to front

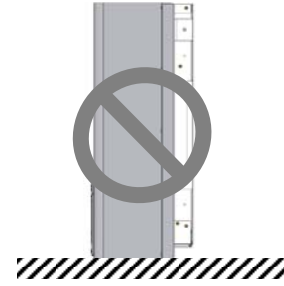

Never use in tower orientation

[Example of installation]

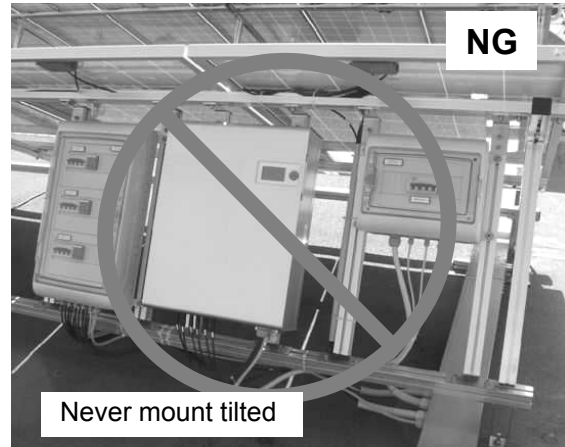

Never mount tilted

■ Installation

- (1) Set up "Mounting base plate" in the place where the weight (41.5kg) of KP100L can be endured. The installation location should endure the torque of 176N-m with each installation screw. Use the reinforced board when strength of the wall is insufficient. Please prepare the board to reinforce it .
- (2) Mark the positions of the 8 outer mounting holes onto the wall with the mounting base plate.
- (3) Drill the 8 marked holes in the wall, and then drive the 8 Snap Bushings by the hammer into the wall, when the wall is a hard wall like concrete.
- (4) Fix the mounting base plate to the wall by using 8 mounting screws of the attachment.

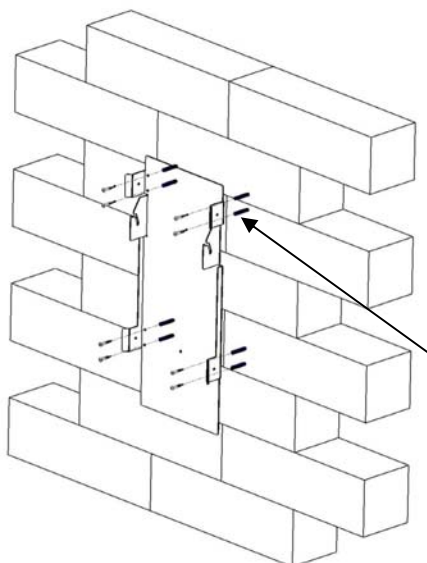

Use Snap Bushings when the wall is a hard wall like concrete

8mm diameter
55mm depth

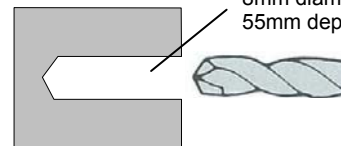

Snap bushing

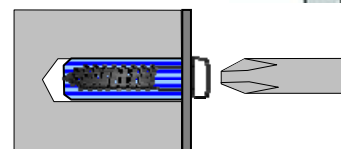
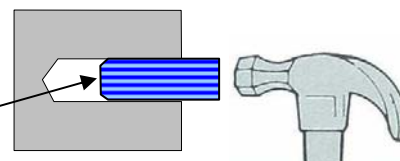

4. Installation

- (5) Set it in product so that 4 places in the part where both sides of the mounting base plate are curved may come outside of the heat sink
- (6) Set it up so that the 2 screws in the both sides of the heat sink may fall into the ditch of the mounting base plate.

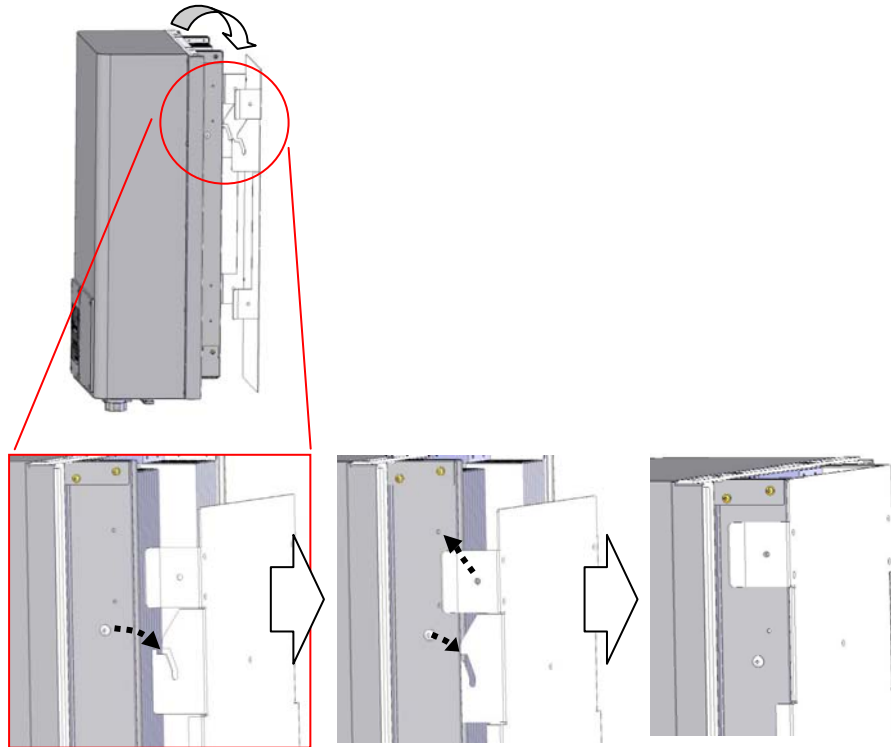

- (7) Fix the heat sink and the mounting base plate by using bundled M4X10 with plane washer and spring washer in 4 points. (Tightening torque: 1.5 to 1.7 N-m).

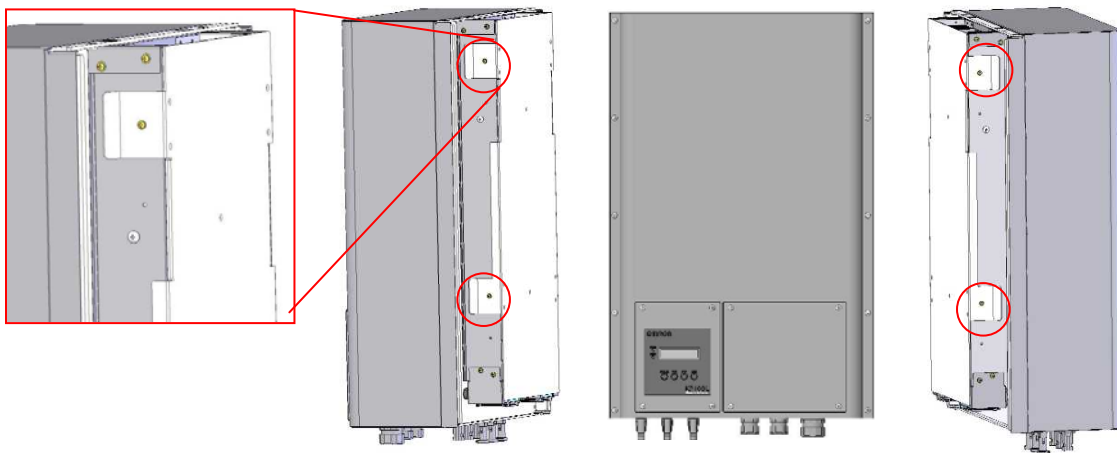

5. Wiring

■ Remove the cover foreside R.

Before wiring, remove the 4 screws, and the cover foreside R.

■ Connecting the AC Cable

Connect the AC cable to the KP100L as follow steps

(1) Remove the cap of the AC cable clamp, and take the rubber bush (none hole) out.

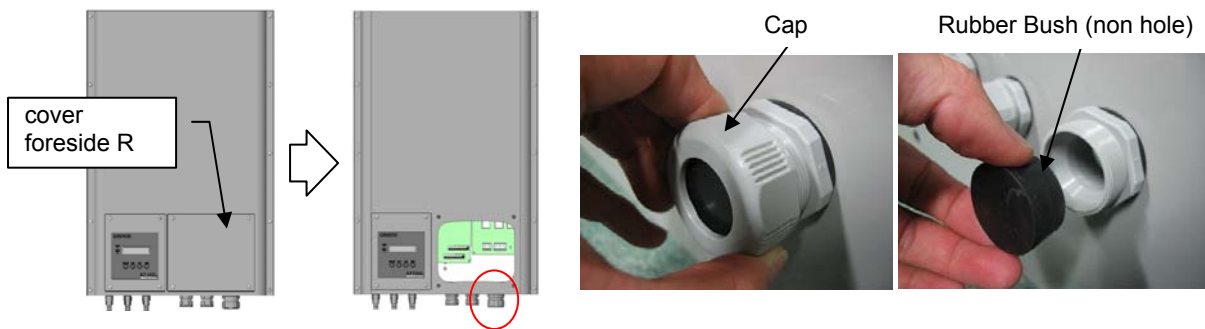

(2) Pass the AC cable through the cap and the rubber bush of the cable clamp.
Rubber bush (one hole type and five hole type) is bundled.

(2)-1 In the case of you use the rubber bush of the one hole type

The rubber bush of one hole is used for connection with multiple-cable.

(2)-2 In the case of you use the rubber bush of the five holes type

The rubber bush of five holes is used for connection with five individual cables.

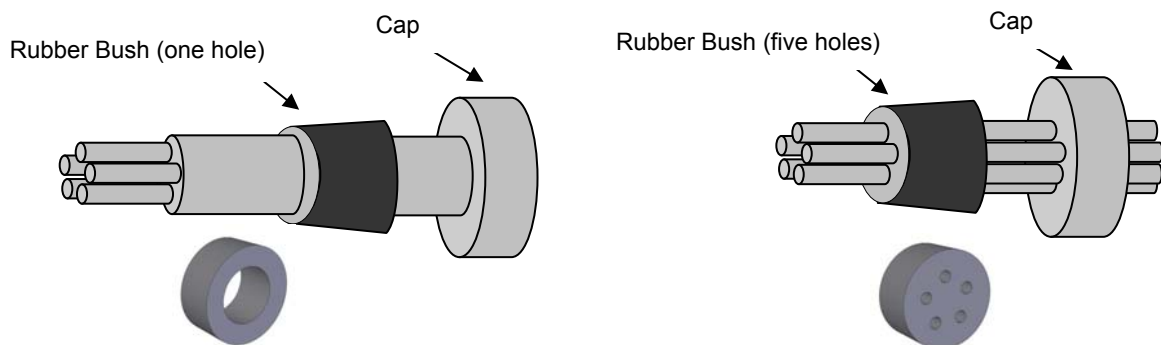

(2)-3 Use the cable and the wire in the table below.

	Diameter of cable	Cross-sectional area of wire
The rubber bush for one hole	φ18.5~20.5mm	4mm ² / AWG12 or more
The rubber bush for five holes	φ3.5~4.0mm	4mm ² / AWG12

Don't use cables that the loss is more than 1% of nominal power of the inverter.

Refer to the figure below to check possible cable lengths for the different cross-sectional area.

5. Wiring

(3) Use the rod terminal for AC wiring like the picture below when connected with KP100L.

wire	Rod terminal (Phoenix Contact)	crimping pliers (Phoenix Contact)
4 mm ²	Al 4-10 GY	CRIMFFOX 6, CRIMPFOX 10s
6 mm ²	Al 6-12 YE	CRIMFFOX 6, CRIMPFOX 10s
10 mm ²	Al 10-12 RD	CRIMPFOX 10s

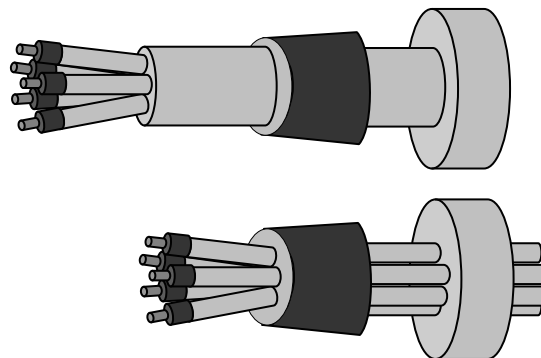

(4) Insert wire in the interior of AC terminal block, and tighten by a minus driver.

(Tightening torque :1.2 to1.8 N·m)

The AC cable edge must use the one that pressure was put on to Rod terminal.

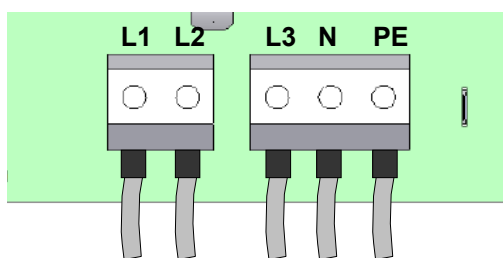

(5) Tighten the cap of the cable clamp surely.

When tightening the cable clamp is insufficient, the effect of the waterproof is not achieved.

■ Attachment of cover foreside R

Mount the cover foreside R by the 4screws surely(tightening torque : 1.5 to1.7N·m)

When tightening the screws is insufficient, the effect of the waterproof is not achieved.

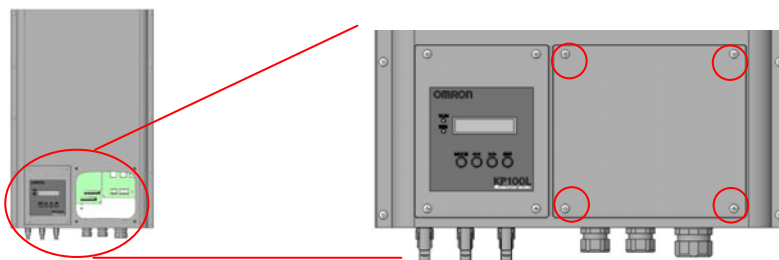

■ Connecting the Communication Cable and the AUX Cable

Refer to User's manual for wiring of the communication cable and the AUX cable.

■ Options

The screw of hexagon (For Italy)

The customer who uses KP100L in Italy must buy the following screw. And, fix Cover foreside R according to the following procedure. This is a requirements of ENEL Guideline.

Refer to User's manual for detail installation.

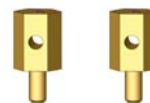

DC SWITCH

It is necessary to use DC switch or circuit breaker which complies to the installation standard for photovoltaic systems (VDE0100-712). When you install where you require the DC switch such as Germany, please consult your OMRON representative

■ Wiring the KP100L to the Solar Modules

- First make sure the maximum open circuit voltage V_{oc} of each PV string is below 850 VDC under any condition.
- Always connect solar module positive (+) terminal to KP100L DC positive (+) terminal, and the solar module negative (-) terminal to KP100L DC negative (-) terminal.
- KP100L has 3 MPPT. Usually solar modules are connected to 3 DC terminals as illustrated in figure below. Mount the enclosed MC caps onto MC connector that is not used. Each set of DC terminals takes a maximum DC input of 13A. 3 pairs of DC terminals can take a combined input of up to 33A. Maximum PV input power for each tracking is 5,500W.
- One PV-panel can be connected to 3 DC input as illustrated in figure below. To fully optimize the PV output set-up, use the following configuration guidelines:
 - (a) For PV output $\leq 13A$, use a single pair of DC terminals.
 - (b) For $13A \leq$ PV output $\leq 26A$, use 2 sets of DC terminals.
 - (c) For $26A \leq$ PV output $\leq 33A$, use 3 sets of DC terminals.

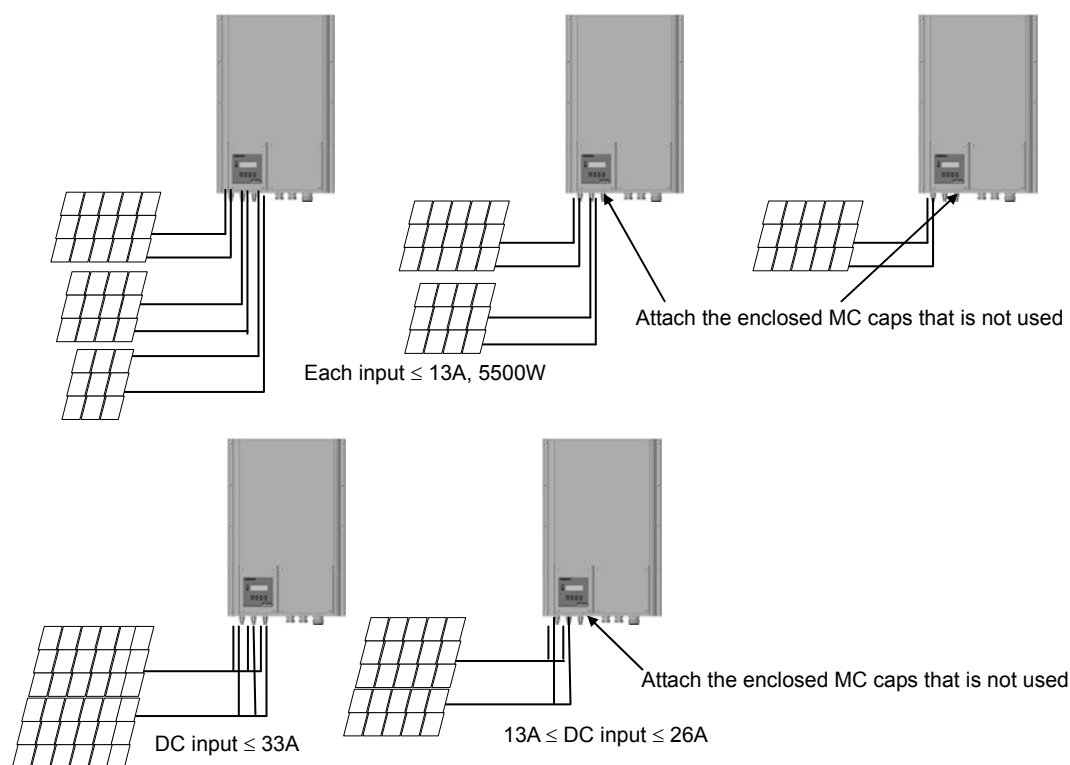

Be especially careful about electric shocks during the daytime, because that is when the solar modules are in the power generating mode. Confirm the polarity of the cable from the solar modules to ensure correct connection and make sure that there is no slackness of MC connectors.

For the DC terminal of the KP100L, use the standard MC4 connectors. Model type of connectors is shown below. If you use MC3 series in the solar module, refer to these conversion cable.

Solar module side (MC4 series)		KP100L side (MC4 series)	
			
PV-KST4	PV-KBT4	PV-ADBP4	PV-ADSP4

6. Check List

Each of the Inverter has been installed to be used in accordance with the instructions listed in the manual or the product specification; eg. ambient temperature, annual operation time, installation place, no direct exposure to sun light and direct rain fall, mounting distances and protection against toxic gas and other harmful gas environment, dust and other contamination.

Ensure that you have checked and verified the following points:

- The provided mounting base plate for the KP100L is attached and fixed securely and correctly.
- The inverter is mounted securely in the mounting base plate.
- There has been no use of parts or accessory other than Omron has provided and/ or specify.
- There has been no drop-off of the inverter or damage given when the inverter are installed and set up.
- There has been no mechanical stress, which applies continuously yet negligible, such as vibration or shock to the inverter.
- The heat sink of the inverters is purged to avoid any clog of air convection and do not place any objects close to the air duct.
- All the wires and cables are connected to correct polarity.
- MC connectors have been fastened and not deteriorated.
- "Screws of AC cable" has been fastened.
- Cover foreside R has been fastened and the cable clamps have been tightened correctly.
- Solar modules have been installed properly and they perform as designated.
- Open circuit voltage MUST not exceed 850 VDC under operating temperature (-20 to +60°C).
- Short-circuit DC current MUST not exceed 13 A DC per one DC input.
- Cables on AC side have low resistance enough to constrain an increase of grid voltage at the terminal of connection (or other side of grid transformer) and loss is less than 1% of rated power of the inverter.
- There has been a protection against lightening surge put on DC side of the inverter, in particular, in a place where it is often seen
- There has been a protection against surge noise (spike) and grid instability on AC grid lines to avoid any adverse influence from a nearby construction work or similar unusual event
- There has been a protection against a less quality grid connection, in particular, in an industrial estate or near one
- There has been no modifications performed by a party other than OMRON in a product specification.
- There has been no other apparatus without grounding (eg. washing machine) on the same grid lines.
- There has been no installation or set-up such as that cause the inverter to chatter repeatedly intervention and re-generation of power at startup and stop.

■ Preliminary Confirmations

Check the following items before wiring.

No.	Inspection Item	Procedure, Measurement or Confirmation	Check
1	Solar module installation condition	Visual confirmation: Refer to the technical manual for the solar modules.	
2	KP100L installation condition	Visual confirmation: Make sure none of the mounting screws are loose. Make sure that the KP100L and the mounting base plate are securely fixed with the mounting screws.	
3	Wiring, connection, and conductivity	Visual confirmation: Inspect for looseness in clamps and screws, proper wire connection, and conductivity.	
4	KP100L ground resistance	Measurement confirmation: Standard: 100 Ω max. KP100L actual measurement: _____ Ω	
5	Connect the Solar modules	High voltages exist when the Solar modules are exposed to the sun. Exposed terminals of the Solar modules are live, and can cause electric shock. Avoid making physical contact with live parts of the device.	
		After the Solar modules are connected to KP100L, the input voltage is greater than 200 VDC, the LCD displays the country setting at first time operation. Set a specified country. Refer to "Procedure at the First Time Operation" for detail.	
		After the Solar modules are connected to KP100L, the input voltage is greater than 200 VDC and the AC grid is not connected to the in KP100L, the Data Logger LCD displays. <div style="border: 1px solid black; padding: 5px; width: fit-content; margin: 5px auto;"> Fault: E1-0 No Utility </div>	
		Voltage measurement for each solar module string Measurement confirmation: <u>DC1</u> V <u>DC2</u> V <u>DC3</u> V	
6	Grid voltage confirmation	Measure to confirm that the grid voltage is about 230 V.	
		Actual measurement: <u>AC(L1)</u> V <u>AC(L2)</u> V <u>AC(L3)</u> V	
7	Power-ON delay time for grid-connected operation	Step 1: Check the connection between KP100L and AC Connection System. And then check the connection between the Grid and AC Connection unit. Close the AC breaker or fuse in the unit.	
		Step 2 Measure the time until operation resumes.	
		Step 3 Confirm that the displays the status "Normal" and that the KP100L performs the grid connect operation. <div style="border: 1px solid black; padding: 5px; width: fit-content; margin: 5px auto;"> Pac: 1.5kW 0.50/ 0.50/ 0.50kW </div>	
		The KP100L is feeding power to the grid, and the green LED displays.	
8	Confirm the wattmeter	The Wattmeter installed to count the injected electricity should work while the inverter displays that electricity is being injected.	

7. Descriptions of Operation

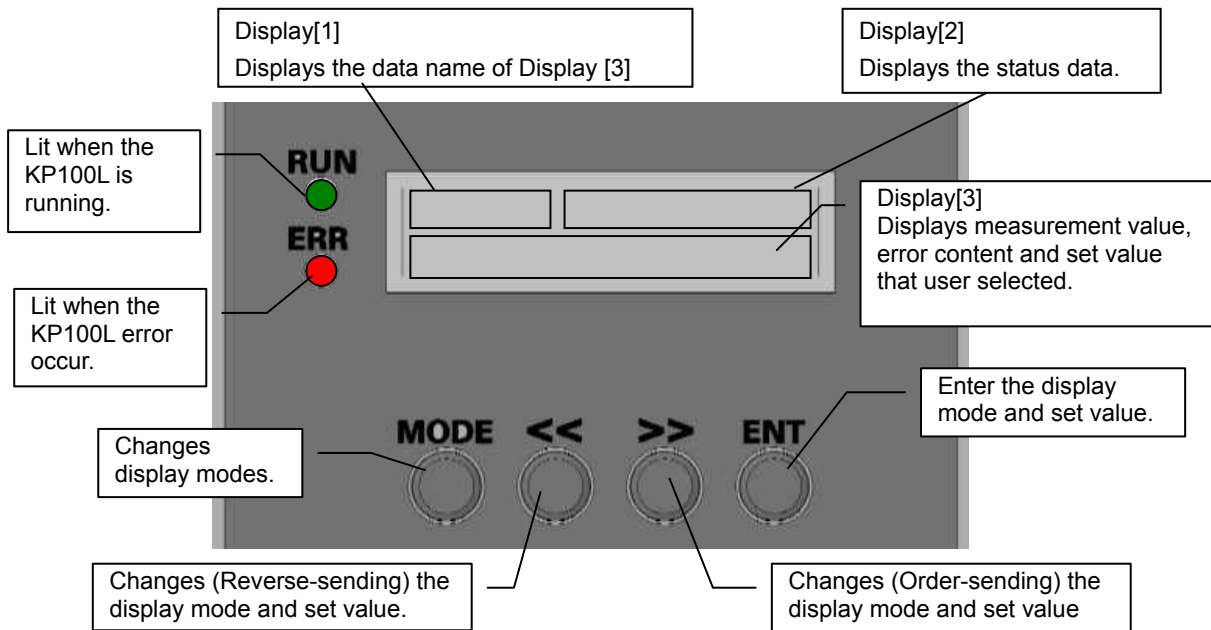

■ Procedure at the First Time Operation

The procedure at the first time operation shows below.

- (1) Connect the Solar modules to the KP100L.
- (2) After the LCD becomes the display of the country setting, set a specified country.
- (3) Make sure that the display of the country setting is correct.
- (4) After turning OFF the AC breaker, wire the AC to the KP100L.
- (5) Turn ON the AC breaker.
- (6) Make sure that the KP100L starts running as indicated by the LCD..

■ Country Setting

Procedure of the Country Setting

WARNING

After once setting the country setting, you can't change the country setting. Be careful when you set it. Significant property damage may possibly occur. Do not use the product with a mistake of the country setting. Contact store purchased when you fix the country setting by mistake.

The display moves to the display of the setting of the country when you start KP100L with Country Setting not fixed. Refer to the figure below for setup. Table shows the relation between the menu and the country. You can't set the country other than countries shown in the table. The KP100L complies with local and national standards when correct country is selected.

Refer to User's manual for the detect level in each country.

Menu	[GER]	[FRA]	[GRE]	[CZE]	[DEN]	[TUR]	[RSA]	[ESP]	[POR]	[ITA]
Country	Germany	France	Greece	Czech Republic	Denmark	Turkey	Republic of South Africa	Spain	Portugal	Italy

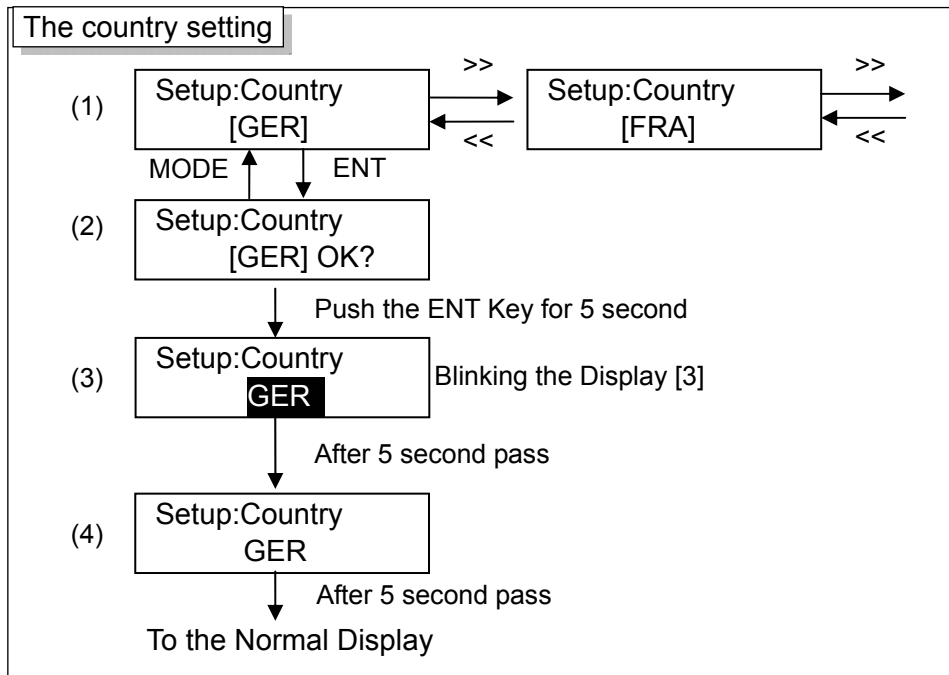

- (1) In the country selection display, select the items that you want to set by the “<<” and “>>” key and you decide the item by the ENT key.
- (2) In the last confirmation display of country setting, fix the country setting when you push the ENT key for 5 second. You can return to the country selection display, when you push the MODE key.
- (3) While the last confirmation display of country setting, the country name does the blinking display. The key operation becomes invalid. After 5 second, display change to next display.
- (4) In the last display of the setting country, the country name does the lighting display. The key operation becomes invalid. After 5 second, display change to next display.

Procedure of the country setting confirmation

Make sure that the country setting is correct. Refer to the below Figure about the setting.

- (1) In the normal display, if you press the MODE key for 5 second, display change to the selection display.
- (2) In the selection display, push >> and choose "Check".
- (3) After you choose “Check”, push the ENT key.
- (4) Display shows the country setting. Make sure the name of a country .
- (5) Push the MODE key to return the selection display. After that push the MODE key to return normal display

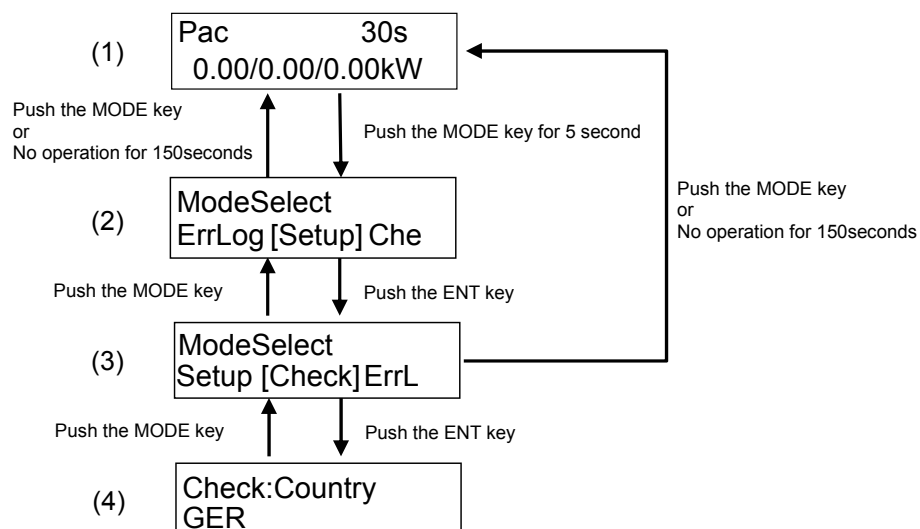

8. Display transition

The display according to the state of the KP100L and the key operation is done after the KP100L starts. The following show the image of the display transition. Refer to User's manual of the KP100L for more detail information.

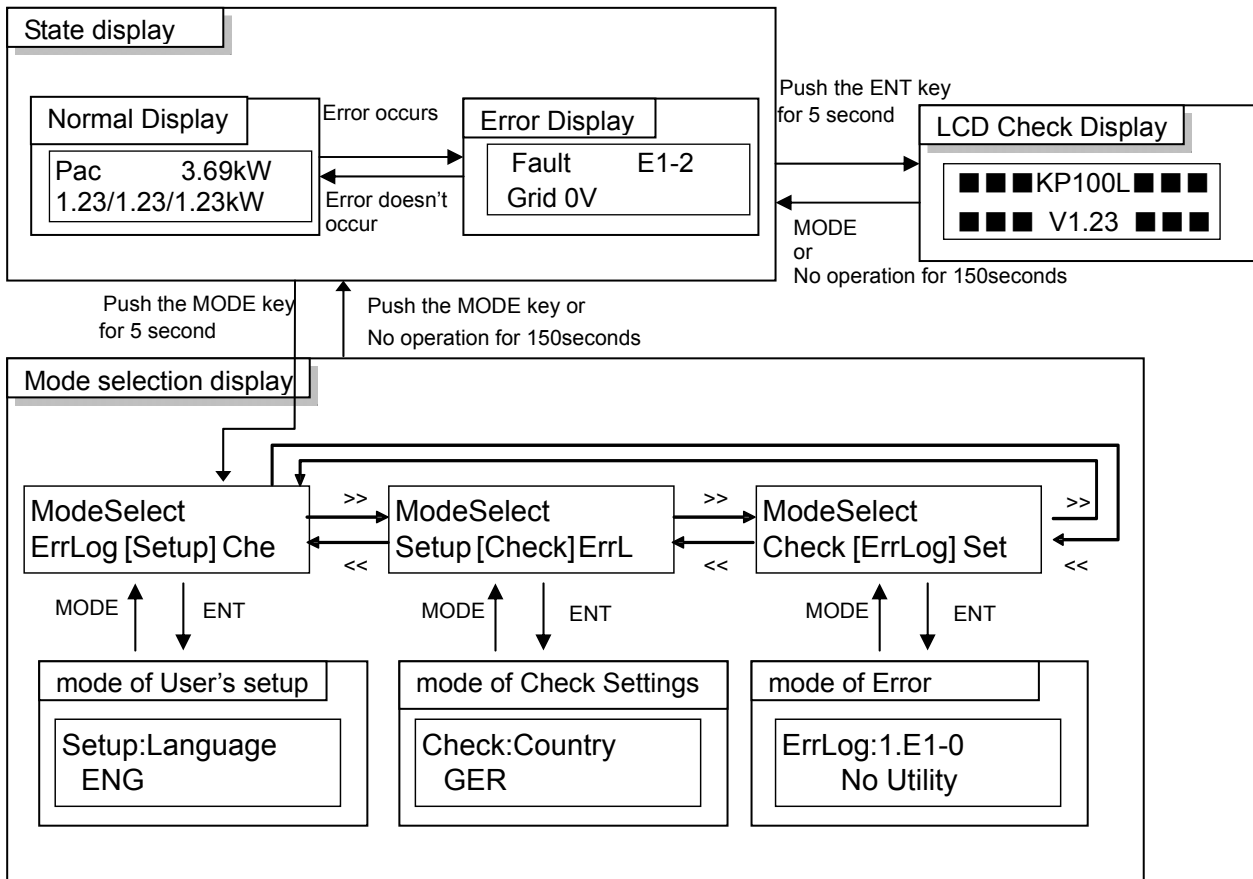

9. Contact

■ Contact Address

Regional Headquarters
OMRON EUROPE B.V.
Wegalaan 67-69-2132 JD Hoofddorp
The Netherlands
Tel: +31 (0)23-5681300/Fax: +31 (0)23-5681388

OMRON Corporation
Environmental Solutions Business Headquarters
Power Electronics Business Promotion Department
2-1-2, Nishikusatsu, Kusatsu-city, Shiga, Pref.,525-0035 Japan