

K3HB Digital Indicators

Communications User's Manual

Revised March 2005

Preface

OMRON products are manufactured for use according to proper procedures by a qualified operator and only for the purposes described in this manual.

This manual describes the functions, performance, and application methods needed for optimum use of the K3HB.

Please observe the following items when using the K3HB.

- This product is designed for use by qualified personnel with a knowledge of electrical systems.
- Read this manual carefully and make sure you understand it well to ensure that you are using the K3HB correctly.
- Keep this manual in a safe location so that it is available for reference when required.

Visual Aids

The following headings appear in the left column of the manual to help you locate different types of information.

Note Indicates information of particular interest for efficient and convenient operation of the product.

1,2,3... 1. Indicates lists of one sort or another, such as procedures, checklists, etc.

Trademarks

- DeviceNet is a registered trademark of the Open DeviceNet Vendors Association, Inc.
- Other product names and company names that appear in this manual are the trademarks or registered trademarks of the respective companies.

© OMRON, 2004

All rights reserved. No part of this publication may be reproduced, stored in a retrieval system, or transmitted, in any form, or by any means, mechanical, electronic, photocopying, recording, or otherwise, without the prior written permission of OMRON.

No patent liability is assumed with respect to the use of the information contained herein. Moreover, because OMRON is constantly striving to improve its high-quality products, the information contained in this manual is subject to change without notice. Every precaution has been taken in the preparation of this manual. Nevertheless, OMRON assumes no responsibility for errors or omissions. Neither is any liability assumed for damages resulting from the use of the information contained in this publication.

Read and Understand this Manual

Please read and understand this manual before using the product. Please consult your OMRON representative if you have any questions or comments.

Warranty and Limitations of Liability

WARRANTY

OMRON's exclusive warranty is that the products are free from defects in materials and workmanship for a period of one year (or other period if specified) from date of sale by OMRON. OMRON MAKES NO WARRANTY OR REPRESENTATION, EXPRESS OR IMPLIED, REGARDING NON-INFRINGEMENT, MERCHANTABILITY, OR FITNESS FOR PARTICULAR PURPOSE OF THE PRODUCTS. ANY BUYER OR USER ACKNOWLEDGES THAT THE BUYER OR USER ALONE HAS DETERMINED THAT THE PRODUCTS WILL SUITABLY MEET THE REQUIREMENTS OF THEIR INTENDED USE. OMRON DISCLAIMS ALL OTHER WARRANTIES, EXPRESS OR IMPLIED.

LIMITATIONS OF LIABILITY

OMRON SHALL NOT BE RESPONSIBLE FOR SPECIAL, INDIRECT, OR CONSEQUENTIAL DAMAGES, LOSS OF PROFITS OR COMMERCIAL LOSS IN ANY WAY CONNECTED WITH THE PRODUCTS, WHETHER SUCH CLAIM IS BASED ON CONTRACT, WARRANTY, NEGLIGENCE, OR STRICT LIABILITY.

In no event shall the responsibility of OMRON for any act exceed the individual price of the product on which liability is asserted.

IN NO EVENT SHALL OMRON BE RESPONSIBLE FOR WARRANTY, REPAIR, OR OTHER CLAIMS REGARDING THE PRODUCTS UNLESS OMRON'S ANALYSIS CONFIRMS THAT THE PRODUCTS WERE PROPERLY HANDLED, STORED, INSTALLED, AND MAINTAINED AND NOT SUBJECT TO CONTAMINATION, ABUSE, MISUSE, OR INAPPROPRIATE MODIFICATION OR REPAIR.

Application Considerations

SUITABILITY FOR USE

OMRON shall not be responsible for conformity with any standards, codes, or regulations that apply to the combination of products in the customer's application or use of the products.

At the customer's request, OMRON will provide applicable third party certification documents identifying ratings and limitations of use that apply to the products. This information by itself is not sufficient for a complete determination of the suitability of the products in combination with the end product, machine, system, or other application or use.

The following are some examples of applications for which particular attention must be given. This is not intended to be an exhaustive list of all possible uses of the products, nor is it intended to imply that the uses listed may be suitable for the products.

- Outdoor use, uses involving potential chemical contamination or electrical interference, or conditions or uses not described in this manual.
- Nuclear energy control systems, combustion systems, railroad systems, aviation systems, medical equipment, amusement machines, vehicles, safety equipment, and installations subject to separate industry or government regulations.
- Systems, machines, and equipment that could present a risk to life or property.

Please know and observe all prohibitions of use applicable to the products.

NEVER USE THE PRODUCTS FOR AN APPLICATION INVOLVING SERIOUS RISK TO LIFE OR PROPERTY WITHOUT ENSURING THAT THE SYSTEM AS A WHOLE HAS BEEN DESIGNED TO ADDRESS THE RISKS, AND THAT THE OMRON PRODUCTS ARE PROPERLY RATED AND INSTALLED FOR THE INTENDED USE WITHIN THE OVERALL EQUIPMENT OR SYSTEM.

PROGRAMMABLE PRODUCTS

OMRON shall not be responsible for the user's programming of a programmable product, or any consequence thereof.

Disclaimers

CHANGE IN SPECIFICATIONS

Product specifications and accessories may be changed at any time based on improvements and other reasons.

It is our practice to change model numbers when published ratings or features are changed, or when significant construction changes are made. However, some specifications of the products may be changed without any notice. When in doubt, special model numbers may be assigned to fix or establish key specifications for your application on your request. Please consult with your OMRON representative at any time to confirm actual specifications of purchased products.

DIMENSIONS AND WEIGHTS

Dimensions and weights are nominal and are not to be used for manufacturing purposes, even when tolerances are shown.

PERFORMANCE DATA

Performance data given in this manual is provided as a guide for the user in determining suitability and does not constitute a warranty. It may represent the result of OMRON's test conditions, and the users must correlate it to actual application requirements. Actual performance is subject to the OMRON Warranty and Limitations of Liability.

ERRORS AND OMISSIONS

The information in this document has been carefully checked and is believed to be accurate; however, no responsibility is assumed for clerical, typographical, or proofreading errors, or omissions.



Safety Precautions

■ Definition of Precautionary Information





The following notation is used in this manual to provide precautions required to ensure safe usage of the product.

The safety precautions that are provided are extremely important to safety. Always read and heed the information provided in all safety precautions.



The following notation is used.



 WARNING	<p>Indicates a potentially hazardous situation which, if not avoided, will result in minor or moderate injury, or may result in serious injury or death. Additionally there may be significant property damage.</p>
 CAUTION	<p>Indicates a potentially hazardous situation which, if not avoided, may result in minor or moderate injury or in property damage.</p>

■ Symbols

Symbol		Meaning
Caution		<p>General Caution Indicates non-specific general cautions, warnings, and dangers.</p>
		<p>Electrical Shock Caution Indicates possibility of electric shock under specific conditions.</p>
Prohibition		<p>General Prohibition Indicates non-specific general prohibitions.</p>
Mandatory Caution		<p>General Caution Indicates non-specific general cautions, warnings, and dangers.</p>

■ Precautions

 WARNING	
Do not touch the terminals while power is being supplied. Doing so may possibly result in electric shock. Make sure that the terminal cover is installed before using the product.	
Always provide protective circuits in the network. Without protective circuits, malfunctions may possibly result in accidents that cause serious injury or significant property damage. Provide double or triple safety measures in external control circuits, such as emergency stop circuits, interlock circuits, or limit circuits, to ensure safety in the system if an abnormality occurs due to malfunction of the product or another external factor affecting the product's operation.	

 CAUTION	
Do not allow pieces of metal, wire clippings, or fine metallic shavings or filings from installation to enter the product. Doing so may occasionally result in electric shock, fire, or malfunction.	
Do not use the product in locations where flammable or explosive gases are present. Doing so may occasionally result in minor or moderate explosion, causing minor or moderate injury, or property damage.	
Do not attempt to disassemble, repair, or modify the product. Doing so may occasionally result in minor or moderate injury due to electric shock.	
Do not use the equipment for measurements within Measurement Categories III and IV for K3HB-X and II, III, and IV for K3HB-S, K3HB-V, K3HB-H, K3HB-R, K3HB-P, and K3HB-C (according to IEC61010-1). Doing so may occasionally cause unexpected operation, resulting in minor or moderate injury, or damage to the equipment. Use the equipment for measurements only within the Measurement Category for which the product is designed.	
Perform correct setting of the product according to the application. Failure to do so may occasionally cause unexpected operation, resulting in minor or moderate injury, or damage to the equipment.	
Ensure safety in the event of product failure by taking safety measures, such as installing a separate monitoring system. Product failure may occasionally prevent operation of comparative outputs, resulting in damage to the connected facilities and equipment.	
Tighten the screws on the terminal block and the connector locking screws securely using a tightening torque within the following ranges. Loose screws may occasionally cause fire, resulting in minor or moderate injury, or damage to the equipment. Terminal block screws: 0.43 to 0.58 N·m Connector locking screws: 0.18 to 0.22 N·m	

 **CAUTION**

Make sure that the product will not be adversely affected if the DeviceNet cycle time is lengthened as a result of changing the program with online editing. Extending the cycle time may cause unexpected operation, occasionally resulting in minor or moderate injury, or damage to the equipment.

Before transferring programs to other nodes or changing I/O memory of other nodes, check the nodes to confirm safety. Changing the program or I/O memory of other nodes may occasionally cause unexpected operation, resulting in minor or moderate injury, or damage to the equipment.



Precautions for Safe Use

- (1) Do not use the product in the following locations.
 - Locations subject to direct radiant heat from heating equipment
 - Locations where the product may come into contact with water or oil
 - Locations subject to direct sunlight
 - Locations where dust or corrosive gases (in particular, sulfuric or ammonia gas) are present
 - Locations subject to extreme temperature changes
 - Locations where icing or condensation may occur
 - Locations subject to excessive shocks or vibration
- (2) Do not use the product in locations subject to temperatures or humidity levels outside the specified ranges or in locations prone to condensation. If the product is installed in a panel, ensure that the temperature around the product (not the temperature around the panel) does not go outside the specified range.
- (3) Provide sufficient space around the product for heat dissipation.
- (4) Use and store the product within the specified temperature and humidity ranges. If several products are mounted side-by-side or arranged in a vertical line, the heat dissipation will cause the internal temperature of the products to rise, shortening the service life. If necessary, cool the products using a fan or other cooling method.
- (5) The service life of the output relays depends on the switching capacity and switching conditions. Consider the actual application conditions and use the product within the rated load and electrical service life. Using the product beyond its service life may result in contact welding or burning.
- (6) Install the product horizontally.
- (7) Mount to a panel between 1 and 8-mm thick.
- (8) Use the specified size of crimp terminals (M3, width: 5.8 mm max.) for wiring. To connect bare wires, use AWG22 (cross section: 0.326 mm²) to AWG14 (cross section: 2.081 mm²) to wire the power supply terminals and AWG28 (cross section: 0.081 mm²) to AWG16 (cross section: 1.309 mm²) for other terminals. (Length of exposed wire: 6 to 8 mm)
- (9) In order to prevent inductive noise, wire the lines connected to the product separately from power lines carrying high voltages or currents. Do not wire in parallel with or in the same cable as power lines. Other measures for reducing noise include running lines along separate ducts and using shield lines.
- (10) Ensure that the rated voltage is achieved no longer than 2 s after turning the power ON.
- (11) Allow the product to operate without load for at least 15 minutes after the power is turned ON.
- (12) Do not install the product near devices generating strong high-frequency waves or surges. When using a noise filter, check the voltage and current and install it as close to the product as possible.
- (13) Do not use thinner to clean the product. Use commercially available alcohol.
- (14) Be sure to confirm the name and polarity for each terminal before wiring the

terminal block and connectors.

- (15) Use the product within the noted supply voltage and rated load.
- (16) Do not connect anything to unused terminals.
- (17) Output turns OFF when the mode is changed or settings are initialized. Take this into consideration when setting up the control system.
- (18) Install an external switch or circuit breaker that complies with applicable IEC60947-1 and IEC60947-3 requirements and label them clearly so that the operator can quickly turn OFF the power.
- (19) Use the specified cables for the communications lines and stay within the specified DeviceNet communications distances. Refer to the User's Manual (Cat. No. N129) for information on communications distances and cables.
- (20) Do not pull the DeviceNet communications cables with excessive force or bend them past their natural bending radius.
- (21) Do not connect or remove connectors while the DeviceNet power is being supplied. Doing so will cause product failure or malfunction.
- (22) Use cables with a heat resistance specification of 70°C min.

EC Directives

- EMC Directives

Concepts

EMC Directives

OMRON devices that comply with EC Directives also conform to the related EMC standards so that they can be more easily built into other devices or the overall machine. The actual products have been checked for conformity to EMC standards. Whether the products conform to the standards in the system used by the customer, however, must be checked by the customer.

EMC-related performance of the OMRON devices that comply with EC Directives will vary depending on the configuration, wiring, and other conditions of the equipment or control panel on which the OMRON devices are installed. The customer must, therefore, perform the final check to confirm that devices and the overall machine conform to EMC standards.

Conformance to EC Directives

The K3HB Digital Indicators comply with EC Directives. To ensure that the machine or device in which the Unit is used complies with EC Directives, the Unit must be installed as follows:

- 1,2,3...**
1. You must use reinforced insulation or double insulation for the DC power supplies used for the communications power supply, internal power supply, and I/O power supplies.
 2. Units complying with EC Directives also conform to the Common Emission Standard (EN61326). Radiated emission characteristics (10-m regulations) may vary depending on the configuration of the control panel used, other devices connected to the control panel, wiring, and other conditions. You must therefore confirm that the overall machine or equipment complies with EC Directives.

The following example shows one means of reducing noise.

- 1,2,3...**
1. Noise from the communications cable can be reduced by installing a ferrite core on the communications cable within 10 cm of the DeviceNet Master Unit.
Ferrite Core (Data Line Filter): 0443-164151 (manufactured by Fair-Rite Products Co., Ltd.)

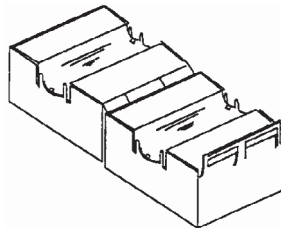

Impedance specifications	
25 MHz	105 Ω
100 MHz	190 Ω

2. Wire the control panel with as thick and short electric lines as possible and ground to 100 Ω min.
3. Keep DeviceNet communications cables as short as possible and ground to 100 Ω min.

Complying with Safety Standards

For the DeviceNet power supply, always use a power supply with reinforced or double insulation, that complies with EN/IEC standards.

Conformance to the standards is for indoor applications only.

Related Manuals

The following manuals are also related to the K3HB Digital Indicator. Refer to these manuals when using the K3HB.

K3HB Digital Indicators Communications User's Manual

(This manual)

Describes the models, communications functions, specifications, and application methods of K3HB Digital Indicators with communications.

K3HB-S/-X/-V/-H Digital Indicators User's Manual

(N128)

Describes the models, functions, specifications, and application methods of K3HB-S/-X/-V/-H Digital Indicators. Refer to this manual for information on specifications and functions other than DeviceNet.

K3HB-R/-P/-C Digital Indicators User's Manual

(N136)

Describes the models, functions, specifications, and application methods of K3HB-R/-P/-C Digital Indicators. Refer to this manual for information on specifications and functions other than DeviceNet.

DeviceNet Operation Manual

(W267)

Describes the configuration and connection forms for a DeviceNet network. Also describes connection methods and specifications for devices used to connect to the network, such as cables and connectors, as well as methods for supplying communications power. When using DeviceNet, obtain this manual in advance and be sure you understand its contents.

CVM1-DRM21-V1/C200HW-DRM21-V1 DeviceNet Master Units Operation Manual

(W379)

Describes the specifications, functions, and application methods for the DeviceNet Master Units for CVM1/CV-series, C200HS, and C200HX/HG/HE PLCs.

SYSMAC CS/CJ Series DeviceNet Units Operation Manual

(W380)

Describes the specifications, functions, and application methods for the DeviceNet Units for CS/CJ-series PLCs. (A CS/CJ-series DeviceNet Unit can function simultaneously as both a DeviceNet master and slave.)

DeviceNet Configurator Version 2 Operation Manual

(W382)

Describes the application methods of the DeviceNet Configurator. The DeviceNet Configurator is used to build, set, and manage DeviceNet networks on graphic displays. Refer to this manual as required.

TABLE OF CONTENTS

Part 1: CompoWay/F

SECTION 1

CompoWay/F Communications	1-1
1-1 Communications Method	1-2
1-2 Frames (CompoWay/F Communications)	1-5
1-3 FINS-mini Text	1-6
1-4 Variable Areas	1-8
1-5 Reading the Variable Area	1-9
1-6 Writing to the Variable Area	1-10
1-7 Operation Commands (CompoWay/F Communications)	1-11
1-8 Setting Areas	1-12
1-9 Commands and Responses (CompoWay/F Communications)	1-13
1-10 Program Example	1-23

SECTION 2

List of Settings	2-1
-------------------------------	------------

Part 2: DeviceNet

SECTION 1

Overview	3-1
1-1 Features	3-2
1-2 Specifications	3-5

SECTION 2

Operating Procedures	4-1
2-1 Introduction	4-2
2-2 Functions Supported Only by the K3HB-DRT	4-4

SECTION 3

Parts, Installation, and Wiring	5-1
3-1 Part Names and Functions	5-2
3-2 DeviceNet Communications Cables Wiring	5-4

SECTION 4

Remote I/O Communications	6-1
4-1 Overview	6-2
4-2 I/O Allocation	6-2
4-3 Ladder Programming Examples	6-7

TABLE OF CONTENTS

SECTION 5

Explicit Message Communications 7-1

- 5-1 Overview of Explicit Message Communications 7-2
- 5-2 Sending CompoWay/F Commands to the Digital Indicator 7-4
- 5-3 Explicit Messages Specific to DeviceNet-compatible Digital Indicators 7-6

SECTION 6

Communications Performance 8-1

- 6-1 Remote I/O Communications Performance. 8-2
- 6-2 Message Communications Performance 8-6

SECTION 7

Troubleshooting and Maintenance 9-1

- 7-1 Indicators and Error Processing. 9-2
- 7-2 Maintenance. 9-3

SECTION 8

Additional Information for DeviceNet 10-1

- 8-1 Detailed DeviceNet Specifications 10-2
- 8-2 Mounted Objects 10-3
- 8-3 DeviceNet Connection Hardware 10-7
- 8-4 Glossary 10-10

Part 3: BCD Output

SECTION 1

BCD Communications 11-1

- 1-1 Features 11-2
- 1-2 Specifications. 11-3
- 1-3 Accessories 11-6
- 1-4 Precautions for BCD Programming. 11-7
- 1-5 Programming Example 1: Connecting to a PLC 11-7
- 1-6 Programming Example 2: Connecting to a PLC 11-10

Index I-1

Revision History R-1

About this Manual:

This manual describes communications for the K3HB Digital Indicators and includes the sections described below divided into two parts according to the type of communications.

Please read this manual carefully and be sure you understand the information provided before attempting to setup or operate communications for a K3HB Digital Indicator.

Part 1: CompoWay/F

Section 1 describes CompoWay/F communications.

Section 2 provides a list of K3HB settings.

Part 2: DeviceNet

Section 1 introduces the features and specifications of K3HB-DRT Digital Indicators.

Section 2 outlines the basic operating procedures for the K3HB-DRT Digital Indicators.

Section 3 describes the methods used to install and wire K3HB-DRT Digital Indicators.

Section 4 describes the input (IN) areas and output (OUT) areas that K3HB-DRT Digital Indicators can use for remote I/O communications. The methods to allocate data for master communications are also described using sample programming.

Section 5 describes how to send explicit messages to the K3HB-DRT Digital Indicator, including how to send CompoWay/F commands using explicit messages.

Section 6 provides information on the time required for a complete communications cycle, for an output response to be made to an input, to start the system, and to send messages.

Section 7 describes error processing, periodic maintenance operations, and troubleshooting procedures needed to keep the DeviceNet Network operating properly. Details on resetting replaced Digital Indicators are also provided. Read through the error processing procedures in both this manual and the operation manual for the DeviceNet master being used before operation so that operating errors can be identified and corrected more quickly.

Section 8 provides DeviceNet specifications, tables of mounted objects, and tables of DeviceNet connection hardware.

Part 3: BCD Output

Section 1 describes BCD communications using K3HB Digital Indicators.



WARNING Failure to read and understand the information provided in this manual may result in personal injury or death, damage to the product, or product failure. Please read each section in its entirety and be sure you understand the information provided in the section and related sections before attempting any of the procedures or operations given.

Part 1: CompoWay/F

SECTION 1	CompoWay/F Communications	1-1
1-1	Communications Method	1-2
1-2	Frames (CompoWay/F Communications).....	1-5
1-3	FINS-mini Text	1-6
1-4	Variable Areas	1-8
1-5	Reading the Variable Area	1-9
1-6	Writing to the Variable Area	1-10
1-7	Operation Commands (CompoWay/F Communications).....	1-11
1-8	Setting Areas	1-12
1-9	Commands and Responses (CompoWay/F Communications)	1-13
1-10	Program Example	1-23
SECTION 2	List of Settings.....	2-1

Part 1: CompoWay/F

SECTION 1

CompoWay/F Communications

This section describes communications using CompoWay/F.

1-1	Communications Method	1-2
1-1-1	CompoWay/F Communications Protocol	1-2
1-1-2	Communications Specifications	1-2
1-1-3	Transfer Protocol (CompoWay/F Communications)	1-2
1-1-4	Cable Connections	1-3
1-2	Frames (CompoWay/F Communications)	1-5
1-2-1	Command Frame	1-5
1-2-2	Response Frame	1-5
1-3	FINS-mini Text	1-6
1-4	Variable Areas	1-8
1-5	Reading the Variable Area	1-9
1-6	Writing to the Variable Area	1-10
1-7	Operation Commands (CompoWay/F Communications)	1-11
1-8	Setting Areas	1-12
1-9	Commands and Responses (CompoWay/F Communications)	1-13
1-9-1	Monitor Value Read (CompoWay/F Communications)	1-13
1-9-2	Setting Data Read (CompoWay/F Communications)	1-13
1-9-3	Monitor Value/Setting Data Compound Read (CompoWay/F Communications)	1-14
1-9-4	Protect Level Setting Data Write	1-15
1-9-5	Setting Data Write (CompoWay/F Communications)	1-15
1-9-6	Setting Data Compound Write (CompoWay/F Communications)	1-16
1-9-7	Monitor Value/Setting Data Compound Read Store (Write)	1-16
1-9-8	Monitor Value/Setting Data Compound Read Store Check (Read)	1-17
1-9-9	Monitor Value/Setting Data Compound Store Read	1-17
1-9-10	Write via Communications	1-18
1-9-11	Reset	1-18
1-9-12	Bank Selection	1-18
1-9-13	Zero Execute/Cancel	1-19
1-9-14	Software Reset	1-19
1-9-15	Move to Setting Area 1	1-20
1-9-16	Move to Protect Level	1-20
1-9-17	Initialize Settings	1-20
1-9-18	Read Machine Attributes	1-21
1-9-19	Controller Status Read (CompoWay/F Communications)	1-21
1-9-20	Echo Back Test	1-22
1-10	Program Example	1-23

1-1 Communications Method

1-1-1 CompoWay/F Communications Protocol

CompoWay/F is OMRON's unified protocol for general purpose serial communications. Featuring a unified frame format and commands that are compliant with FINS, which has a record of successful use with OMRON programmable controllers, CompoWay/F makes communications easy between multiple components and a computer.

FINS (Factory Interface Network Service)

This is a protocol for message communications between controllers on an OMRON factory automation network.

Supplement

The communications function is used by creating a program on the host computer. As such, the explanations in this chapter are from the perspective of the host computer.

For example, "Read/Write" refers to the host computer reading or writing to the K3HB.

1-1-2 Communications Specifications

- Transfer connection: Multi-point
- Communications method: RS-485 or RS-232C (half duplex)
- Synchronization method: Start-stop
- Baud rate: 9.6k, 19.2k, 38.4k bit/s
- Send code: ASCII
- Data length: 7 or 8 bits
- Stop bit length: 1 or 2 bits
- Error detection: Vertical parity (none, even, or odd)
BCC (Block Check Character)
Start-stop synchronized data configuration
- Flow control: None
- Interface: RS-485 or RS-232C
- Retry function: None

Note Initial settings are shaded.

1-1-3 Transfer Protocol (CompoWay/F Communications)

The host computer sends a command frame, and the K3HB sends a response frame based on the content of the command frame. One response frame is sent in response to one command frame.

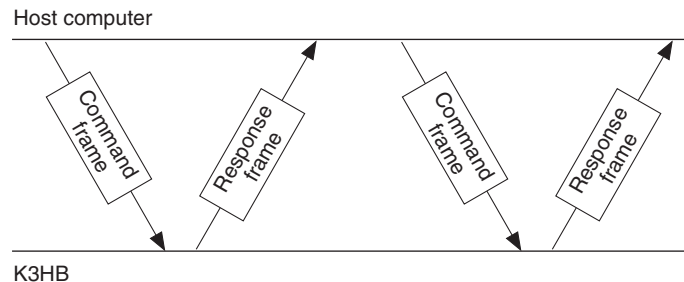

The exchange between the command frame and response frame is explained below.

After a receiving a response from the Digital Indicator, have the host computer wait at least 50 ms before sending the next command.

When writing multiple sets of setting data in a row, such as when writing to the variable area or performing a compound write, controllability may be affected. Pay attention to the following points:

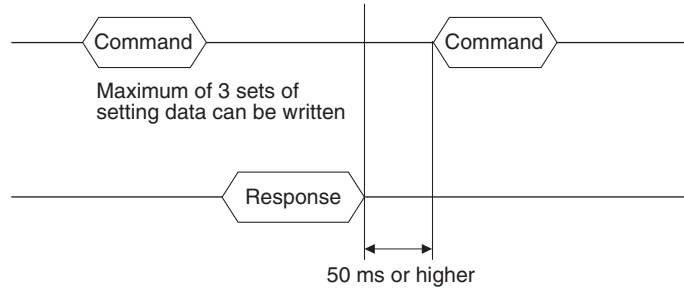

1-1-4 Cable Connections

RS-485

	A	B	C	D	E	
1		RS-485				1
2		RS-485				2
3		RS-485				3
4						4
5						5
6						6

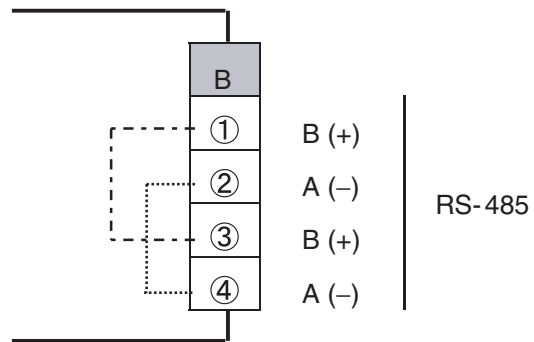

- Use terminals B1 through B4 to communicate with the host. The terminal layout is designed for cross-over wiring and thus the B1-B3 and B2-B4 terminals are connected internally.
- Wiring is configured either 1:1 or 1:N. A maximum of 32 Units, including the host computer can be connected with a 1:N configuration.
- The maximum total cable length is 500 m.
- Use shielded, twisted-pair wires of at least AWG28 to AWG16 for all cables.

Cable Diagram (Reference)

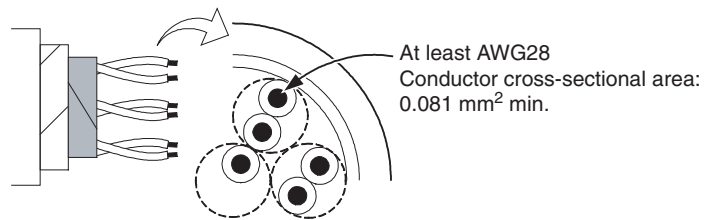

- Attach a terminator to each end of the transmission path, including the host computer. Use a 100- to 125-Ω (1/2 W) resistor for the terminator.
- Use an RS-232C/RS-485 Converter to connect RS-232C devices, such as personal computers.

Converter Example: RS-232C/RS-485 Converter

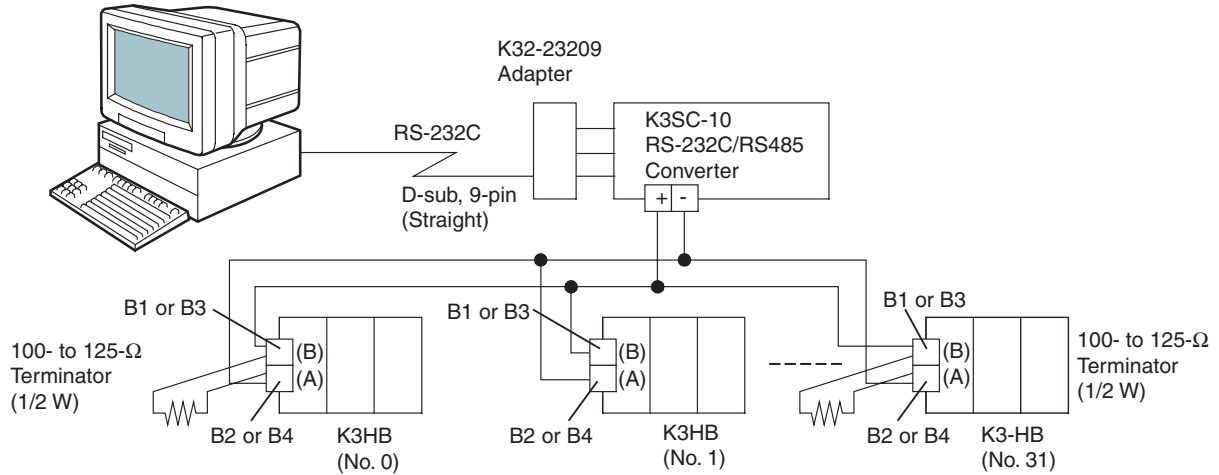

RS-232C

	A	B	C	D	E	
1						1
2		RS-232C				2
3						3
4						4
5						5
6						6

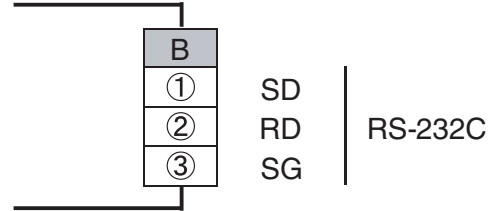

- Use terminals B1 through B3 to communicate with the host.
- Wiring is configured 1:1.
- The maximum cable length is 15 m. Use OMRON's Z3RN RS-232C Optical Interface to extend the wiring path.
- Use shielded, twisted-pair wires of at least AWG28 to AWG16 for all cables. (Same wire used for RS-485 cable.)

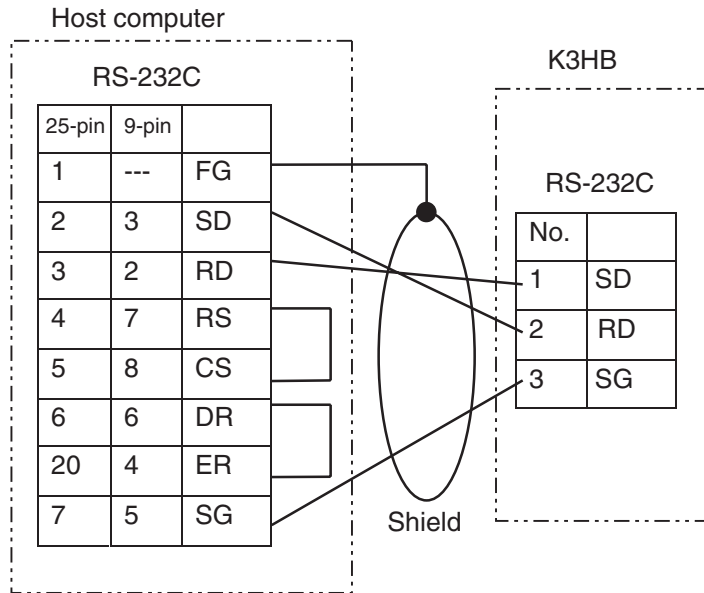

1-2 Frames (CompoWay/F Communications)

Based on CompoWay/F protocol, commands from the host computer and responses from the K3HB take the form of frames.

The data comprising command frames and response frames are explained below.

In the following explanation, an “H” following a numeric value (for example 02H) indicates that the value is a hexadecimal number. A number or letters enclosed in quotation marks (for example “00”) is an ASCII character.

1-2-1 Command Frame

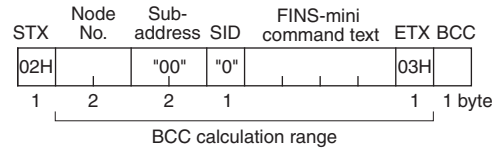

STX	Code that indicates the beginning of the communications frame (02H). Be sure to set this code in the leading byte.
Node No.	This number specifies the destination. Specify the Unit No. of the K3HB. When broadcasting to all units, specify “XX”. Responses are not sent to a broadcast.
Sub-address	Not used on the K3HB. Be sure to set to “00”.
SID (Service ID)	Not used on the K3HB. Be sure to set to “0”.
FINS-mini Command text	The text of the command.
ETX	Code that indicates the end of the text (03H).
BCC	Block Check Character. This stores the result of the BCC calculation from Node No. to EXT.

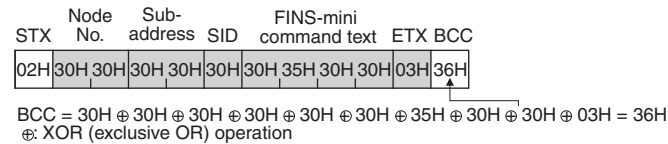

1-2-2 Response Frame

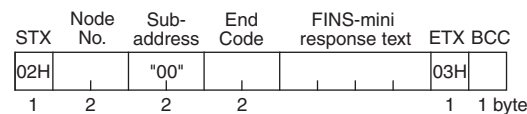

Supplement

A response is not sent to command frames that do not end with ETX.BCC characters.

STX	Code that indicates the beginning of the communications frame (02H). Be sure to set this code in the leading byte.
Node No.	The number that was specified in the command frame is repeated here. This is the Unit No. of the responding K3HB.
Sub-address	Not used on the K3HB. Set to “00”.

End code	Returns the result of the command executed as instructed by the command frame.
FINS-mini Response text	Text of the response
ETX	Code that indicates the end of the text (03H)
BCC	Block Check Character Stores the result of the BCC calculation from Node No. to EXT.

End Codes (CompoWay/F Communications)

End code	Name	Description	Error detection order of priority
"0F"	FINS command error	Could not execute the specified FINS command	8
"10"	Parity error	Sum of bits that are "1" in received data does not agree with the set communications parity value.	2
"11"	Framing error	Stop bit of command frame characters is "0".	1
"12"	Overrun error	Attempted to transfer new data because received data buffer is already full.	3
"13"	BCC error	Calculated BCC different from received BCC.	5
"14"	Format error	Characters other than "0" to "9" or "A" to "F" in FINS-mini command text. In the case of an echo-back test, when data other than the test data is sent. No SID and FINS-mini command text, or no FINS-mini command text. "MRC/SRC" not correct in FINS-mini command text.	7
"16"	Sub-address error	No sub-address, SID, or FINS-mini command text; or sub-address less than 2 characters and no SID and FINS-mini command text.	6
"18"	Frame length error	The received frame exceeds the required number of bytes.	4
"00"	Normal end	Command was executed normally without error.	None

1-3 FINS-mini Text

The FINS-mini command text and FINS-mini response text form the body of command/response communications.

FINS-mini command text and FINS-mini response text are configured as follows.

Command Text

FINS-mini command text consists of an MRC (main request code) and an SRC (sub request code), followed by the required data.

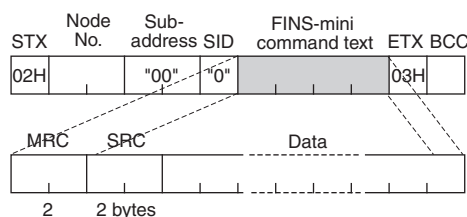

Response text

FINS-mini response text consists of the MRC and SRC, followed by an MRES (main response code) and SRES (sub response code), and then the required data.

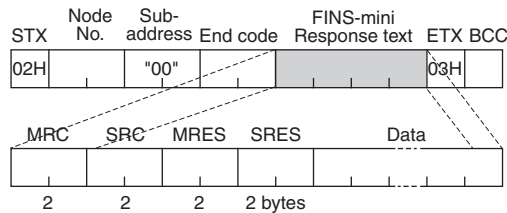

If the specified FINS-mini command was not successfully executed, the response will only contain the MRC, SRC, MRES and SRES.

List of FINS-mini Service Commands (CompoWay/F Communications)

MRC	SRC	Service name	Description
"01"	"01"	Monitor value/setting data read	Reads monitor values/setting data.
"01"	"02"	Monitor value/setting data write	Writes monitor values/setting data.
"01"	"04"	Monitor value/setting data compound read	Performs multiple reads of monitor values/setting data.
"01"	"13"	Monitor value/setting data compound write	Performs multiple writes of monitor values/setting data.
"01"	"10"	Monitor value/setting data compound stored read	Sequentially reads contents of addresses specified in "monitor value/setting data compound read store."
"01"	"11"	Monitor value/setting data compound read store (write)	Specifies addresses to be read using "monitor value/setting data compound stored read."
"01"	"12"	Monitor value/setting data compound read store check (read)	Reads the contents stored using "variable area compound read store."
"05"	"03"	Machine attribute read	Reads the model and other attributes.
"06"	"01"	Controller status read	Reads the operation status.
"08"	"01"	Echo-back test	Performs an echo-back test.
"30"	"05"	Operation command	Commands such as Run/Stop, AT Execute/Cancel, and "Move to setting area 1".

1-4 Variable Areas

The area used for data exchange when communicating with the K3HB is called the “variable area.” The PV is read and various setting data are read and written using the variable area of the K3HB.

Operation commands and reading of machine attributes do not use the variable area.

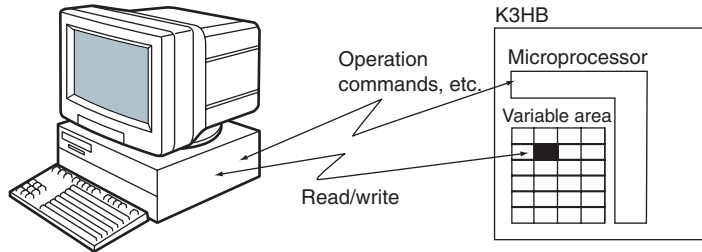

A variable area is accessed by specifying the position of a variable within the variable area using the variable type and address.

Variable Types

Variable types in variable areas are as follows:

Variable type	Description	Area
C0	Read-only parameters	Setting area 0 (during operation)
C1	Protect level	
C2	RUN level	
C4	Initial setting level	Setting area 1 (during stop)
C5	Input adjustment level	
C6	Display adjustment level	
C7	Scaling level	
C8	Comparative set value level	
C9	Linear output level	
CA	Communications setting level	
CB	Advanced function setting level	

Addresses (CompoWay/F Communications)

Each variable type has an address. Addresses are 2 bytes long and written in hexadecimal. Addresses are assigned according to units of access size.

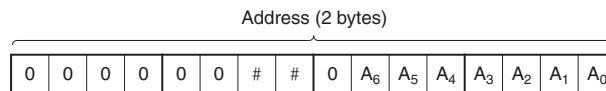

For more information on addresses, refer to *List of Settings* on page 2-1.

Number of Elements

The number of elements is expressed as a 2-byte hexadecimal number. The specification range for the number of elements varies depending on the command. See *1-9 Commands and Responses (CompoWay/F Communications)* (page 1-13) for more information.

For example, if the number of elements is 0010, the first 16 elements of data (H'10) from the address are specified.

Set Values

Values read and written to the variable area are expressed in hexadecimal and disregard the decimal point position (negative values are expressed as a two's complement).

Example: D'105.0 → H'0000041A

The variable is an 8-digit number in hexadecimal. Negative values are expressed as a two's complement. The decimal is disregarded.

For example, if the PV of the K3HB is 105.0, it will be read as H'0000041A (105.0 → 1050 → H'0000041A).

1-5 Reading the Variable Area

The data area is read by setting the required data in the following FINS-mini command text format.

Command

FINS-mini Command Text

MRC	SRC	Variable type	Read start address	Bit position	Number of elements
"01"	"01"			"00"	"0001" to "0019"
2	2	2	4	2	4

Data name	Explanation
MRC/SRC	Specifies the FINS-mini monitor value/setting data read command.
Variable type	Specify a variable type.
First address of read	Specify the address for the beginning of the read.
Bit position	Not used on the K3HB. Specify "00".
Number of elements	Specifies the number of variables to read (max. of 25 (H'19)). Not needed for a compound read.

Response

FINS-mini Response Text

MRC	SRC	Response code (MRES/SRES)	Data to be read
"01"	"01"		
2	2	4	Number of elements × 8 bytes (for compound read, number of elements × 10 bytes)

Data name	Explanation
MRC/SRC	The FINS-mini command text appears here.
Response code	Result of execution of the command.
Read data	Values for variables that were read.

Response Codes

Response code	Error name	Explanation
"1001"	Command length too long	The command is too long.
"1002"	Command length too short	The command is too short.
"1101"	Area type error	Incorrect variable type.
"110B"	Response length too long	Number of elements > 25 (H'0019).
"1100"	Parameter error	Specified bit position is other than "00".
"2203"	Operation error	Unit error, unit change, display unit error, internal non-volatile memory error
"0000"	Normal end	

1-6 Writing to the Variable Area

Write to the data area by setting the required data in the following FINS-mini command text format.

Command

FINS-mini Command Text

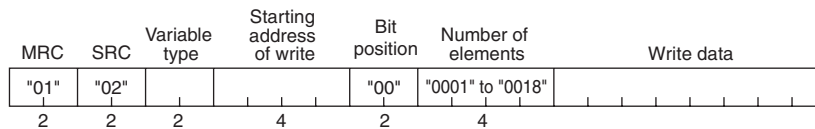

Data name	Explanation
MRC/SRC	Specifies the FINS-mini monitor value/setting data write command.
Variable type	Specify a variable type.
First address of write	Specify the address for the beginning of the write.
Bit position	Not used on the K3HB. Specify "00".
Number of elements	Specifies the number of variables to be written (max. of 24 (H'18)). Not needed for a compound write.
Write data	Enter data to be written.

Response

FINS-mini Response Text

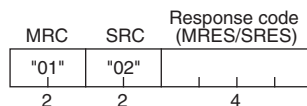

Data name	Explanation
MRC/SRC	FINS-mini command text appears here.
Response code	Result of execution of the command.

Response Codes

Response code	Error name	Explanation
"1002"	Command length too short	The command is too short.
"1101"	Area type error	Incorrect variable type.
"1003"	Number of elements/Data number do not agree	The specified number of elements does not agree with the actual number of data elements.
"1100"	Parameter error	Bit position specification other than "00". Written data was outside of setting range.
"2203"	Operation error	Write via communications is disabled. Write to setting area 1 was attempted from setting area 0. Write to setting data of protect level was attempted from other than protect level. Calibration level in progress. Unit error, unit change, display unit error, internal non-volatile memory error.
"0000"	Normal end	

1-7 Operation Commands (CompoWay/F Communications)

Operation commands are sent using the following FINS-mini command text format.

Command

FINS-mini Command Text

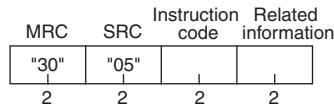

Data name	Explanation
MRC/SRC	Specify the FINS-mini operation command.
Operation code	Specify an operation code.
Related information	Specify information related to the command.

Operation commands for the K3HB are shown in the following table.

Operation code	Description	Related information
00	Write via communications	00: OFF (Disabled) 01: ON (Enabled)
01	Reset	00
02	Bank selection	00 to 07: Bank 0 to 7
03	Zero execute/cancel	00: Zero cancel 01: Zero execute
06	Software reset	00
07	Move to setting area 1	00
08	Move to protect level	00
0B	Initialize settings	00

Note A software reset will not respond (no service PDU response).

Response

FINS-mini Response Text

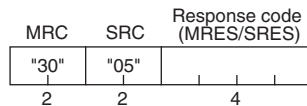

Data name	Explanation
MRC/SRC	FINS-mini command text appears here.
Response code	Result of execution of the command.

Response Codes

Response code	Error name	Explanation
"1001"	Command length too long	The command is too long.
"1002"	Command length too short	The command is too short.
"1100"	Parameter error	Operation code or related information is not correct.

Response code	Error name	Explanation
"2203"	Operation error	Unable to execute because write via communications is disabled. Unable to execute operation command. For more information, see corresponding operation command explanation in <i>1-9 Commands and Responses (CompoWay/F Communications)</i> . Unit error, unit change, display unit error, internal non-volatile memory error
"0000"	Normal end	

1-8 Setting Areas

The K3HB has two setting areas for communications: Setting area 0 and setting area 1.

In setting area 0, control continues.

As such, setting area 0 makes it possible to perform operations that require control to be in progress, such as reading the PV, writing an SP, and run/stop, as well as operations that do not interfere with control. On the other hand, operations that may change control such as writing initial setting data cannot be performed. (Note that setting data that cannot be written can still be read.)

In setting area 1, control is stopped.

This makes it possible to perform operations such as writing initial setting data which are not possible in setting area 0.

When the power is turned on, setting area 0 is selected. To access setting area 1, use the "Move to setting area 1" operation command. To return to setting area 0 from setting area 1, turn off the power or use the "Software reset" operation command.

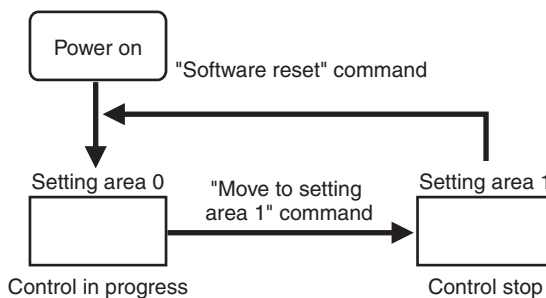

Variable type	Description	Area
C0	Read-only parameters	Setting area 0 (during control)
C1	Protect level	
C2	RUN level	
C4	Initial setting level	Setting area 1 (during stop)
C5	Input adjustment level	
C6	Display adjustment level	
C7	Scaling level	
C8	Comparative set value level	
C9	Linear output level	
CA	Communications setting level	
CB	Advanced function setting level	

1-9 Commands and Responses (CompoWay/F Communications)

The K3HB provides a set of applied commands that make use of variable area read/write commands, operation commands, and other services provided by the CompoWay/F communications protocol.

K3HB applied commands are explained below.

1-9-1 Monitor Value Read (CompoWay/F Communications)

Command

MRC	SRC	Variable type	Address	Bit position	Number of elements
"01"	"01"			"00"	"0001"

Variable type	Address	Monitor value (data name)
"C0"	"0000"	Version
	"0001"	Status
	"0002"	Measurement value
	"0003"	Maximum value
	"0004"	Minimum value

This command is used to read the PV, status, and other monitor values. The number of elements can be set from 0002 to 0019 to allow reading of monitor values in contiguous addresses.

Response

MRC	SRC	Response code	Data
"01"	"01"	"0000"	Monitor value

Response codes: The above indicates a normal end. For the response codes, see *1-5 Reading the Variable Area* (page 1-9).

1-9-2 Setting Data Read (CompoWay/F Communications)

Command

MRC	SRC	Variable type	Address	Bit position	Number of elements
"01"	"01"			"00"	"0001"

Variable type	Address	Setting data (explanation)
"C1" "C2"	"0000" to "0004"	Setting data of setting area 0 Protect level RUN level
"C4" "C5" "C6" "C7" "C8" "C9" "CA" "CB"	"0000" to "0027"	Setting data of setting area 1 Initial setting level Input adjustment level Display adjustment level Scaling level Comparison setting Linear output setting level Communications setting level Advanced function setting level

This command is used to read setting data. The number of elements can be set from 0002 to 0019 to allow successive reading of 2 to 25 items of setting data in contiguous addresses.

To specify the variable type or address, see *SECTION 2 List of Settings* (page 2-1). The upper limit of an address will vary depending on the variable type.

This command can be used in both setting area 0 and setting area 1.

Response

MRC	SRC	Response code	Data
"01"	"01"	"0000"	Setting data

Response codes: The above indicates a normal end. For the response codes, see *1-5 Reading the Variable Area* (page 1-9).

1-9-3 Monitor Value/Setting Data Compound Read (CompoWay/F Communications)

Command

MRC	SRC	Variable type	Address	Bit position	Variable type	Address	Bit position
"01"	"04"			"00"			"00"

Variable type	Address	Bit position
		"00"

Variable type	Address	Setting data (explanation)
"C0"	"0000" to "0004"	Monitor values
"C1" to "C2"	"0000" to "0004"	Setting data of setting area 0
"C4" to "CB"	"0000" to "0027"	Setting data of setting area 1

Multiple monitor values or setting data can be read by sending a single command. Up to 20 items can be read even if the addresses are not contiguous.

To specify the variable type or address, see *SECTION 2 List of Settings* (page 2-1). The upper limit of an address will vary depending on the variable type.

This command can be used in both setting area 0 and setting area 1.

If an area type error or a setting data error occurs in any of the data being read, no data will be read.

Response

MRC	SRC	Response code	Variable type	Data
"01"	"04"	"0000"	Type	Monitor value / Setting data

Variable type	Data
Type	Monitor value / Setting data

Response codes: The above indicates a normal end. For the response codes, see *1-5 Reading the Variable Area* (page 1-9).

1-9-4 Protect Level Setting Data Write

Command

MRC	SRC	Variable type	Address	Bit position	Number of elements	Data
"01"	"02"	"C5"		"00"	"0001"	Protect level setting data

Address	Setting data
"0000"	Operation adjustment protect
"0001"	Setting level protect
"0002"	Setting change protect
"0003"	Forced zero protect
"0004"	MAX/MIN protect

This command writes protect level setting data.

This command is used in setting area 0. An error will result if used in setting area 1.

To use this command, use the "Write via communications" operation command to enable "Write via communications," and then use the "Move to protect level" operation command to move to "Protect level."

Response

MRC	SRC	Response code
"01"	"02"	"0000"

Response codes: The above indicates a normal end. For the response codes, see 1-6 Writing to the Variable Area (page 1-10).

1-9-5 Setting Data Write (CompoWay/F Communications)

Command

MRC	SRC	Variable type	Address	Bit position	Number of elements	Data
"01"	"02"			"00"	"0001"	Setting data

Variable type	Address	Setting data (explanation)
"C1" "C2"	"0000" to "0004"	Setting data of setting area 0 Protect level RUN level
"C4" "C5" "C6" "C7" "C8" "C9" "CA" "CB"	"0000" to "0027"	Setting data of setting area 1 Initial setting level Input adjustment level Scaling level Display adjustment level Comparison setting Linear output setting level Communications setting level Advanced function setting level

The above setting data is written. The number of elements can be set from 2 to 24 to write setting data of contiguous addresses.

To specify an address, see SECTION 2 List of Settings (page 2-1).

Setting data of setting area 1 can be written in setting area 1. An error will result if written in setting area 0.

To use this command, "Write via communications" must be enabled using the "Write via communications" operation command.

Response

MRC	SRC	Response code
"01"	"02"	"0000"

Response codes: The above indicates a normal end. For the response codes, see 1-6 Writing to the Variable Area (page 1-10).

1-9-6 Setting Data Compound Write (CompoWay/F Communications)

Command

MRC	SRC	Variable type	Address	Bit position	Data
"01"	"13"			"00"	Setting data

Variable type	Address	Bit position	Data
		"00"	Setting data

Variable type	Address	Setting data (explanation)
"C1" to "C2"	"0000" to "0004"	Setting data of setting area 0
"C4" to "CB"	"0000" to "0027"	Setting data of setting area 1

Multiple setting data items can be written by sending a single command. Up to 12 items can be written even if the addresses are not contiguous.

To specify the variable type or address, see SECTION 2 List of Settings (page 2-1).

Setting data of setting area 1 is written in setting area 1. An error will result if written in setting area 0.

To use this command, "Write via communications" must be enabled using the "Write via communications" operation command.

Response

MRC	SRC	Response code
"01"	"13"	"0000"

Response codes: The above indicates a normal end. For the response codes, see 1-6 Writing to the Variable Area (page 1-10).

1-9-7 Monitor Value/Setting Data Compound Read Store (Write)

Command

MRC	SRC	Variable type	Read address	Bit position	Variable type	Read address	Bit position
"01"	"11"			"00"			"00"

Variable type	Read address	Bit position
		"00"

Variable type	Address	Setting data (explanation)
"C0"	"0000" to "0004"	Monitor values
"C1" to "C2"	"0000" to "0004"	Setting data of setting area 0
"C4" to "CB"	"0000" to "0027"	Setting data of setting area 1

This command is used to store the addresses of multiple monitor values or setting data that you wish to read.

The stored monitor values or setting data can be read by sending a single "Monitor value/setting data compound store read" command. Up to 20 items can be stored, even if the addresses are not continuous.

To specify the variable type or address, see *SECTION 2 List of Settings* (page 2-1). The upper limit of an address will vary depending on the variable type.

This command can be used in both setting area 0 and setting area 1.

Response

MRC	SRC	Response code
"01"	"11"	"0000"

Response codes: The above indicates a normal end. For the response codes, see *1-5 Reading the Variable Area* (page 1-9).

1-9-8 Monitor Value/Setting Data Compound Read Store Check (Read)

Command

MRC	SRC
"01"	"12"

This is used to check the contents that were stored using "Monitor value/setting data compound read store."

Response

MRC	SRC	Response code	Variable type	Read address
"01"	"12"	"0000"	Type	

Variable type	Read address	Bit position
Type		"00"

Response codes: The above indicates a normal end. For the response codes, see *1-5 Reading the Variable Area* (page 1-9).

1-9-9 Monitor Value/Setting Data Compound Store Read

Command

MRC	SRC
"01"	"10"

This is used to read by a single command the multiple monitor values or setting data items that were stored using "Monitor value/setting data compound read store (write)."

This command can be used in both setting area 0 and setting area 1.

If an area type error or a setting data error occurs in any of the data being read, no data will be read.

Response

MRC	SRC	Response code	Variable type	Data
"01"	"10"	"0000"	Type	Monitor value / Setting data

Variable type	Data
Type	Monitor value / Setting data

Response codes: The above indicates a normal end. For the response codes, see *1-5 Reading the Variable Area* (page 1-9).

1-9-10 Write via Communications

Command

MRC	SRC	Command code	Related information
"30"	"05"	"00"	

Related information	Description
"00"	Write via communications disabled
"01"	Write via communications enabled

This command is used to enable or disable "Write via communications." When sent, it changes the set value of "Write via communications."

When write via communications is disabled, communications cannot be used to write setting data or send operation commands.

The initial setting is "disabled."

This command can be used in both setting area 0 and setting area 1.

Response

MRC	SRC	Response code
"30"	"05"	"0000"

Response codes: The above indicates a normal end. For the response codes, see 1-7 Operation Commands (CompoWay/F Communications) (page 1-11).

1-9-11 Reset

Command

MRC	SRC	Command code	Related information
"30"	"05"	"01"	

Related information	Description
"00"	Reset

This command resets the system to no-measurement status. It can only be used in setting area 0.

Response

MRC	SRC	Response code
"30"	"05"	"0000"

Response codes: The above indicates a normal end. For the response codes, see 1-7 Operation Commands (CompoWay/F Communications) (page 1-11).

1-9-12 Bank Selection

Command

MRC	SRC	Command code	Related information
"30"	"05"	"02"	

Related information	Bank No. selected
"00" to "07"	0 to 7

This command can be used only when "Bank Selection" is set to "Key."

This command is used to change between comparative set values preset in banks. There are 8 banks numbered 0 to 7.

This command can be used in both setting area 0 and setting area 1.

Response

MRC	SRC	Response code
"30"	"05"	"0000"

Response codes: The above indicates a normal end. For the response codes, see 1-7 Operation Commands (CompoWay/F Communications) (page 1-11).

1-9-13 Zero Execute/Cancel

Command

MRC	SRC	Command code	Related information
"30"	"05"	"03"	

Related information	Description
"00"	Zero cancel
"01"	Zero execute

This command is used to execute/cancel the forced zero and tare zero functions. The results of the command will depend on the status of the tare zero setting, as shown below.

Tare zero	Commands executed in order left to right.			
	Zero execute	Zero execute	Zero cancel	Zero cancel
OFF	Forced zero ON	Forced zero ON	Forced zero OFF	Forced zero OFF
ON	Forced zero ON	Tare zero ON	Tare zero OFF	Forced zero OFF

This command can be used only in setting area 0. An operation error will occur in the following situations.

- When there is no-measurement status, there is an input error, or a measurement is outside the display range (but zero cancel is possible.)
- When a RESET or HOLD input is ON
- When the command is used in setting area 1

Response

MRC	SRC	Response code
"30"	"05"	"0000"

Response codes: The above indicates a normal end. For the response codes, see 1-7 Operation Commands (CompoWay/F Communications) (page 1-11).

1-9-14 Software Reset

Command

MRC	SRC	Command code	Related information
"30"	"05"	"06"	"00"

A software reset causes the same operation as turning the power off and on.

This command can be used in both setting area 0 and setting area 1.

To use this command, "Write via communications" must be enabled using the "Write via communications" operation command.

Response

(No response)

A response is not returned to this operation command.

1-9-15 Move to Setting Area 1

Command

MRC	SRC	Command code	Related information
"30"	"05"	"07"	"00"

Use this command to move to setting area 1.

The command is used in setting area 0. Nothing happens if the command is used in setting area 1.

If the command is used when "Initial setting protect" is set to 2 (Disable move to input initial setting level), an operation error will result.

To use this command, "Write via communications" must be enabled using the "Write via communications" operation command.

Response

MRC	SRC	Response code
"30"	"05"	"0000"

Response codes: The above indicates a normal end. For the response codes, see 1-7 Operation Commands (CompoWay/F Communications) (page 1-11).

1-9-16 Move to Protect Level

Command

MRC	SRC	Command code	Related information
"30"	"05"	"08"	"00"

Use this command to move to protect level.

This command is used in setting area 0. If used in setting area 1, an operation error will result.

To use this command, "Write via communications" must be enabled using the "Write via communications" operation command.

Response

MRC	SRC	Response code
"30"	"05"	"0000"

Response codes: The above indicates a normal end. For the response codes, see 1-7 Operation Commands (CompoWay/F Communications) (page 1-11).

1-9-17 Initialize Settings

Command

MRC	SRC	Command code	Related information
"30"	"05"	"0B"	"00"

This returns all settings to the initial settings.

This command is used in setting area 1. If used in setting area 0, an operation error will result.

To use this command, "Write via communications" must be enabled using the "Write via communications" operation command.

Response

MRC	SRC	Response code
"30"	"05"	"0000"

Response codes: The above indicates a normal end. For the response codes, see 1-7 Operation Commands (CompoWay/F Communications) (page 1-11).

1-9-18 Read Machine Attributes

Command

MRC	SRC
"05"	"03"

This command reads the K3HB model and communications buffer size. The command can be used in any state of the K3HB.

Response

MRC	SRC	Response code	Format	Buffer size
"05"	"03"	"0000"		"00D9"

Response codes: The above indicates a normal end. For the response codes, see 1-7 Operation Commands (CompoWay/F Communications) (page 1-11).

Model

K	3	H	B	-	①	②	③		
---	---	---	---	---	---	---	---	--	--

*Bytes 8 and 9 are blank

①		②	
Symbol	Series	Symbol	Input
X	Analog input	VD	DC voltage
		AD	AC voltage
		VA	DC current
		AA	AC current
V	mV input	LC	mV
S	Linear Sensor input	SD	Linear Sensor
H	Temperature input	TA	Temperature
R	Rotary pulse input	NB	NPN/voltage pulse input
		PB	PNP input
P	Time interval input	NB	NPN/voltage pulse input
		PB	PNP input
C	Up/Down counting pulse input	NB	NPN/voltage pulse input
		PB	PNP input

1-9-19 Controller Status Read (CompoWay/F Communications)

Command

MRC	SRC
"06"	"01"

This command reads the operation state of the K3HB. The command can be used in any state of the K3HB.

Response

MRC	SRC	Response code	Operation state	Related information
"06"	"01"	"0000"		

Response codes: The above indicates a normal end. For the response codes, see 1-7 Operation Commands (CompoWay/F Communications) (page 1-11).

Operation State

Operation state	Description
00	Operating (no errors in setting area 0, see note)
01	Stopped (all other situations)

Note Measurements outside the display range and no-measurement status do not generate errors and thus may be possible even for an operation state of 00.

Related Information

Bit position	Status
7	Not used
6	Not used
5	Not used
4	Not used
3	Input error B
2	Input error A
1	Measurement outside the display range
0	No-measurement status

Note (1) The bit will be ON (1) or when an error occurs and otherwise will be OFF (0).
 (2) Information is in the same order as status information.

1-9-20 Echo Back Test

Command

MRC	SRC	Test data
"08"	"01"	0 to 200 bytes

This command is used to perform an echo back test. The command can be used in any state of the K3HB. Keep the test data within the following ranges depending on the communications data length.

Communications data length	Description
7 bits	ASCII code H'20 to H'7E
8 bits	ASCII code H'20 to H'7E or H'A1 to H'FE

Response

MRC	SRC	Response code	Test data
"08"	"01"	"0000"	0 to 200 bytes

Response codes: The above indicates a normal end. For the response codes, see 1-7 Operation Commands (CompoWay/F Communications) (page 1-11).

1-10 Program Example

N88Basic

This program displays the response from the K3HB on the screen when command data is entered from the keyboard.

Command data from the unit number to the number of elements must be entered.

The program was created in N88BASIC.

```

1000 '-----
1010 'PROGRAM: E5AR/ER Communication Sample Program(CompoWay/F)
1020 'VERSION:1.00
1030 '(c)Copyright OMRON Corporation 2003
1040 All Rights Reserved
1050 '-----
1060 '
1070 '====Communication port (PARITY=EVEN, DATA=7, STOP=2) ====='
1080 '
1090 OPEN "COM:E73" AS #1
1100 '
1110 *SENDDATA
1120 '
1130 ===== Communication routine=====
1140 '
1150 -----Communication data input-----
1160 INPUT "SEND DATA:",SEND$
1170 '
1180 -----If no input, jump to end routine-----
1190 IF SEND$ = " " THEN *EXITSEND
1200 '
1210 -----BCC calculation-----
1220 BCC = 0
1230 SEND$ = SEND$+CHR$(3)
1240 FOR I=1 TO LEN(SEND$)
1250   BCC = BCC XOR ASC(MID$(SEND$, I, 1))
1260 NEXT I
1270 BCC$ = CHR$(BCC)
1280 '
1290 -----Send-----
1300 SDATA$ = CHR$(2)+SEND$+BCC$
1310 PRINT #1, SDATA$;
1320 '
1330 ===== Receive routine =====
1340 '
1350 RDATA$ = " "
1360 TIMEOUT = 0
1370 *RCVLOOP
1380 -----No response detection-----
1390 TIMEOUT = TIMEOUT+1
1400 IF TIMEOUT > 2000 THEN RESP$ = "No Response":GOTO *RCVEND
1410 IF LOC(1) = 0 THEN *RCVLOOP
1420 '
1430 -----Check for end character (if no end character, continue reading)
1440 RDATA$ = RDATA$+INPUT$(LOC(1),#1)
1450 IF LEN(RDATA$) <2 THEN *RCVLOOP
1460 IF MID$(RDATA$,LEN(RDATA$)-1,1) <> CHR$(3) THEN *RCVLOOP
1470 RESP$ = MID$(RDATA$,2,LEN(RDATA$)-2)
1480 *RCVEND
1490 '
1500 -----Display received data-----
1510 PRINT "RESPONSE: ";RESP$
1520 GOTO *SENDDATA
1530 '
1540 *EXITSEND
1550 =====End routine=====
1560 CLOSE #1
1570 END

```

Operation Example

Reading the present value of Unit No.01.

```

RUN
SEND DATA:010000101C00002000001
RESPONSE:010000010100000000014F

```

SEND DATA: [STX] 01 00 0 0101 C0 0002 00 0001 [ETX] [BCC]

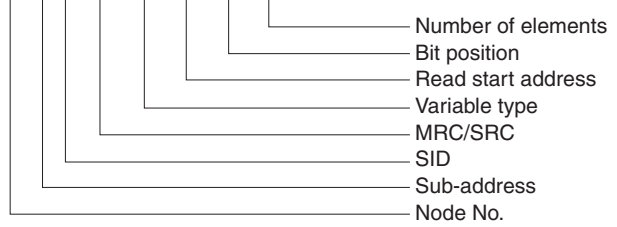

RESPONSE: [STX] 01 00 00 0101 0000 0000014F [ETX] [BCC]

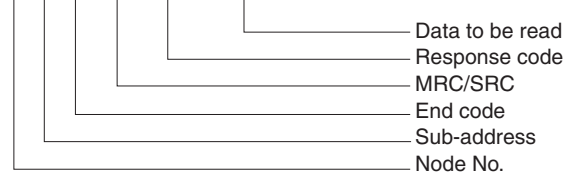

SECTION 2

List of Settings

This list of settings shows addresses for CompoWay/F communications. Refer to the address for the communications protocol that is used.

Status (K3HB)

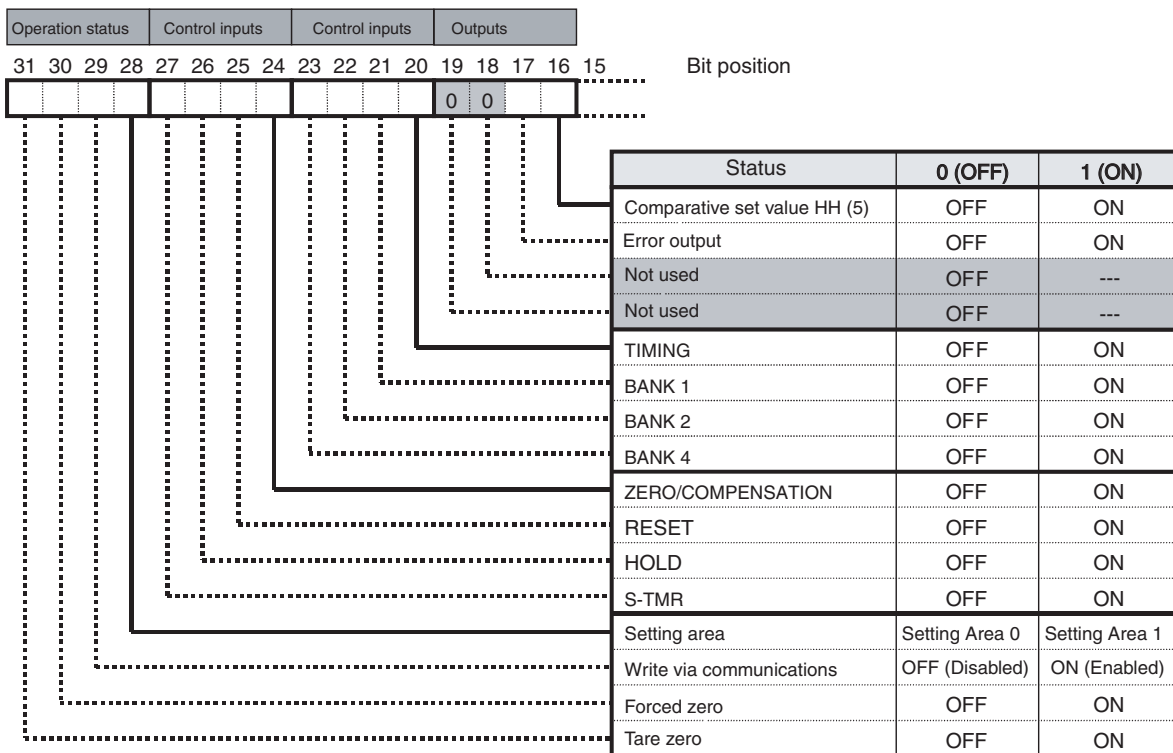
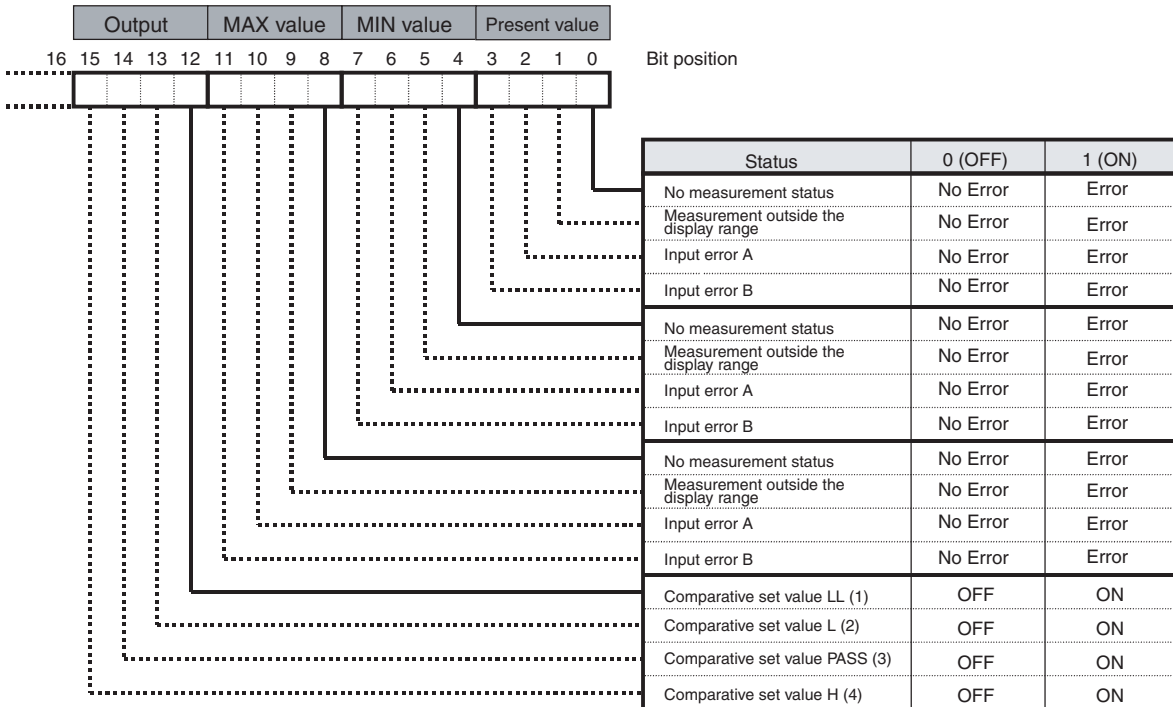

Note The output status turns ON and OFF whether or not an Output Unit is mounted. The output status is undefined if there is no output terminal when Unit 3 outputs a two-relay comparative output pattern. If the output is a two-relay plus one-relay comparative output pattern, LL turns ON when PASS turns ON (output and display colors are not changed in communications status). A 5-output judgement is performed internally regardless of the number of output points. The LL output is always ON in the above configuration so the PASS output does not turn ON. To avoid this situation, the HH/LL status is ignored when Unit 3 uses a two-relay output pattern. The PASS judgement is performed with just H and L for operations like that described.

Communications Monitoring Settings

Variable type	Address	Setting data	Character	Monitor/Setting range	Character	Default setting	Decimal point	Unit	Model				
									X	V	S	H	
C0	0000	Version	---	---	---	---	---	---					
	0001	Status	---	---	---	---	---	---					
	0002	Measurement value	---	H'FFFFB1E1 to H'0001869F (-19,999 to 99,999)	---	---	---	---					
	0003	MAX value	---	H'FFFFB1E1 to H'0001869F (-19,999 to 99,999)	---	---	---	---					
	0004	MIN value	---	H'FFFFB1E1 to H'0001869F (-19,999 to 99,999)	---	---	---	---					

Note The values beginning with H' in the *Monitor/Setting range* column are used when setting or monitoring data via communications.

Protect Level

Variable type	Address	Parameter name	Character	Monitor/Setting range	Character	Default setting	Decimal point	Unit	Model				
									X	V	S	H	
C1	0000	RUN/Adjustment protect	run.Pk	H'00000000 to H'00000002: (0 to 2)	0 to 2	0	---	---					
	0001	Setting level protect	Set.Pk	H'00000000 to H'00000002: (0 to 2)	0 to 2	1	---	---					
	0002	Setting change protect	Yk.Pk	H'00000000: OFF(0) H'00000001: ON(1)	OFF, ON	OFF	---	---					
	0003	Forced zero protect	Zr.Pk	H'00000000: OFF(0) H'00000001: ON(1)	OFF, ON	OFF	---	---					x
	0004	MAX/MIN protect	nan.Pk	H'00000000 to H'00000002: (0 to 2)	0 to 2	0	---	---					

Note The values beginning with H' in the *Monitor/Setting range* column are used when setting or monitoring data via communications.

RUN Level

Variable type	Address	Parameter name	Character	Monitor/Setting range	Character	Default setting	Decimal point	Unit	Model				
									X	V	S	H	
C2	0000	Comparative set value HH	---	H'FFFFB1E1 to H'0001869F (-19,999 to 99,999)	19999 to 99999	99999	According to the decimal position setting	---					
	0001	Comparative set value H	---	H'FFFFB1E1 to H'0001869F (-19,999 to 99,999)	19999 to 99999	99999	According to the decimal position setting	---					
	0002	Comparative set value L	---	H'FFFFB1E1 to H'0001869F (-19,999 to 99,999)	19999 to 99999	19999	According to the decimal position setting	---					
	0003	Comparative set value LL	---	H'FFFFB1E1 to H'0001869F (-19,999 to 99,999)	19999 to 99999	19999	According to the decimal position setting	---					

Note The values beginning with H' in the *Monitor/Setting range* column are used when setting or monitoring data via communications.

Initial Setting Level

Variable type	Address	Parameter name	Character	Monitor/Setting range	Character	Default setting	Decimal point	Unit	Model			
									X	V	S	H
C4	0000	Calculation	εRL	H'00000000: A(0), H'00000001: B(1), H'00000002: K-A(2), H'00000003: A+B(3), H'00000004: A-B(4), H'00000005: K-(A+B)(5), H'00000006: B/A×1000(6), H'00000007: (B/A-1) × 1000(7)	0, 1, 2, 3, 4, 5, 6, 7	0	---	---	x	x		x
	0001	Input type A	εn-εR	X(VD): H'00000000: ±199.99 V(0), H'00000001: ±19.999 V(1), H'00000002: ±1.9999 V(2), H'00000003: 1.0000 to 5.0000 V(3) X(AD): H'00000000: ±199.99 mA(0), H'00000001: ±19.999 mA(1), H'00000002: ±1.9999 mA(2), H'00000003: 4.000 to 20.000 mA(3) X(VA): H'00000000: 0.0 to 400.0 V(0), H'00000001: 0.00 to 199.99 V(1), H'00000002: 0.000 to 19.999 V(2), H'00000003: 0.0000 to 1.9999 V(3) X(AA): H'00000000: 0.000 to 10.000 A(0), H'00000001: 0.0000 to 1.9999 A(1), H'00000002: 0.00 to 199.99 mA(2), H'00000003: 0.000 to 19.999 m(3) V: H'00000000: 0.00 to 199.99 mV(0), H'00000001: 0.000 to 19.999 mV(1), H'00000002: ±100.00 mV(2), H'00000003: ±199.99 mV(3) S: H'00000000: 0 to 20 mA(0) H'00000001: 4 to 20 mA(1), H'00000002: 0 to 5 V(2), H'00000003: 1 to 5 V(3), H'00000004: ±5 V(4), H'00000005: ±10 V(5) H: H'00000000: 0-Pt100(0), H'00000001: 1-Pt100(1), H'00000002: 2-K(2), H'00000003: 3-K(3), H'00000004: 4-J(4), H'00000005: 5-J(5), H'00000006: 6-T(6), H'00000007: 7-E(7), H'00000008: 8-L(8), H'00000009: 9-V(9), H'0000000A: 10-N(10), H'0000000B: 11-R(11), H'0000000C: 12-S(12), H'0000000D: 13-B(13), H'0000000E: 14-W(14)	X(VD): R ud, b ud, ε ud, d ud, X(AD): R Rd, b Rd, ε Rd, d Rd, X(VA): R uR, b uR, ε uR, d uR, X(AA): R RR, b RR, ε RR, d RR, V: R Lε, b Lε, ε Lε, d Lε, S: 0-20, 4-20, 0-5, 1-5, 5, 10 H: 0-Pt, 1-Pt, 2-V, 3-V, 4- J, 5-J, 6-E, 7-E, 8-L, 9- U, 10-N, 11- R, 12-S, 13- B, 14-W	X(VD): R ud X(AD): R Rd X(VA): R uR X(AA): R RR V: R Lε S: 4 to 20 H: 2-V	---	---				
	0002	Power supply frequency	Fε	H'00000000: 50(0), H'00000001: 60(1)	50, 60	50	---	Hz			x	
	0003	Scaling input value A1	εnPR!	H'FFFFB1E1 to H'0001869F (-19,999 to 99,999)	-99999 to 99999	X(VD): -99.99 X(AD): -99.99 X(VA): 0.0 X(AA): 0.000 V: 0.00 S: 4.000	According to the input type	According to the input type				x
0004	Scaling display value A1	d5P.R!	H'FFFFB1E1 to H'0001869F (-19,999 to 99,999)	-99999 to 99999	X(VD): -99999 X(AD): -99999 X(VA): 0 X(AA): 0 V: 0 S: 4000	---	---				x	

List of Settings

Variable type	Address	Parameter name	Character	Monitor/Setting range	Character	Default setting	Decimal point	Unit	Model			
									X	V	S	H
C4	0005	Scaling input value A2	ᄀᄀP.R2	H'FFFFB1E1 to H'0001869F (-19,999 to 99,999)	19999 to 99999	X (VD): 199.99 X (AD): 199.99 X (VA): 400.00 X (AA): 10.000 V: 199.99 S: 20.000	According to the input type	According to the input type				x
	0006	Scaling display value A2	d5P.R2	H'FFFFB1E1 to H'0001869F (-19,999 to 99,999)	19999 to 99999	X (VD): 19999 X (AD): 19999 X (VA): 4000 X (AA): 10000 V: 19999 S: 20000	---	---				x
	0007	Input type B	ᄀᄀ-ᄀᄀ	H'00000000: 0 to 20 mA(0), H'00000001: 4 to 20 mA(1), H'00000002: 0 to 5 V(2), H'00000003: 1 to 5 V(3), H'00000004: ±5 V(4), H'00000005: ±10(5)	0-20, 4-20, 0-5, 1-5, 5, 10	4-20	---	---	x	x		x
	0008	Scaling input value B1	ᄀᄀP.b1	H'FFFFB1E1 to H'0001869F (-19,999 to 99,999)	19999 to 99999	20.000	According to the input type	According to the input type	x	x		x
	0009	Scaling display value B1	d5P.b1	H'FFFFB1E1 to H'0001869F (-19,999 to 99,999)	19999 to 99999	4000	---	---	x	x		x
	000A	Scaling input value B2	ᄀᄀP.b2	H'FFFFB1E1 to H'0001869F (-19,999 to 99,999)	19999 to 99999	20.000	According to the input type	According to the input type	x	x		x
	000B	Scaling display value B2	d5P.b2	H'FFFFB1E1 to H'0001869F (-19,999 to 99,999)	19999 to 99999	20000	---	---	x	x		x
	000C	Constant K	μ	H'FFFFB1E1 to H'0001869F (-19,999 to 99,999)	19999 to 99999	0	---	---	x	x		x
	000D	Decimal point position	dP	H'00000000 to H'00000004: 0 to 4	00000, 0000.0, 00.000, 0.0000	X (VD): 000.00 X (AD): 000.00 X (VA): 000.00 X (AA): 00.000 V: 000.0 S: 00.000	---	---				x
	000F	Temperature units	d-U	H'00000000: °C(0), H'00000001: F(1)	℃, F	℃	---	---	x	x	x	
	000E	Comparative output pattern	ᄀᄀᄀ-P	H'00000000: standard output(0), H'00000001: zone output(1), H'00000002: zone output(2)	ᄀᄀᄀRL, ᄀᄀᄀE, ᄀᄀᄀEᄀ	ᄀᄀᄀRL	---	---				

Note The values beginning with H' in the *Monitor/Setting range* column are used when setting or monitoring data via communications.

Input Adjustment Level

Variable type	Address	Parameter name	Character	Monitor/Setting range	Character	Default setting	Decimal point	Unit	model			
									X	V	S	H
C5	0000	Timing hold	ㄷㄴ-ㄏ	H'00000000: Normal(0), H'00000001: sampling(1), H'00000002: peak(2), H'00000003: bottom(3), H'00000004: peak to peak(4)	ㄴㄴㄴㄴ, 5-ㄏ, ㄱ-ㄏ, ㄴ-ㄱ	ㄴㄴㄴㄴ	---	---				
	0001	ON timing delay	ㄴㄴ-ㄷ	H'00000000 to H'00001387: (0 to 4999)	0 to 4999	0	---	S: ms Others: 100 ms				
	0002	OFF timing delay	ㄴㄴㄴ-ㄷ	H'00000000 to H'00001387: (0 to 4999)	0 to 4999	0	---	S: ms Others: 100 ms				
	0003	Zero limit	ㄷ-ㄷㄴ	H'00000000: OFF(0) H'00000001: ON(1)	ㄴㄴㄴ, ㄴㄴ	ㄴㄴㄴ	---	---				
	0004	Zero limit value	ㄷㄴ-ㄱ	H'00000000 to H'00000063: (0 to 99)	0 to 99	0	---	According to the decimal position setting				
	0005	Step value	5ㄷㄴ	H'00000000: OFF(0), H'00000001: 2(1), H'00000002: 5(2), H'00000003: 10(3)	ㄴㄴㄴ, 2, 5, 10	ㄴㄴㄴ	---	digit				
	0006	Average type	ㄴㄴㄴ-ㄷ	H'00000000: Simple average(0), H'00000001: move average(1)	5ㄴㄴㄴ, ㄴㄴㄴㄴ	5ㄴㄴㄴ	---	---				
	0007	Averaging times	ㄴㄴㄴ-ㄴ	H'00000000: 1(0)/H'00000001: 2(1)/ H'00000002: 4(2)/ H'00000003: 8(3)/ H'00000004: 16(4)/ H'00000005: 32(5)/ H'00000006: 64(6)/ H'00000007: 128(7)/ H'00000008: 256(8)/ H'00000009: 512(9)/ H'00000000A: 1024(10) times	1, 2, 4, 8, 16, 32, 64, 128, 256, 512, 1024	1	---	---				
	0008	Input shift input 1	ㄷㄴ. 1	H'FFFFB1E1 to H'0001869F (-19,999 to 99,999)	-99999 to 99999	-200.0	---	According to the input type	x	x	x	
	0009	Input shift value 1	ㄷㄴ. 1	H'FFFFB1E1 to H'0001869F (-19,999 to 99,999)	-99.99 to 99.99	0.00	2	---	x	x	x	
000A	Input shift input 2	ㄷㄴ. 2	H'FFFFB1E1 to H'0001869F (-19,999 to 99,999)	-99999 to 99999	1000.0	---	According to the input type	x	x	x		
000B	Input shift value 2	ㄷㄴ. 2	H'FFFFB1E1 to H'0001869F (-199.99 to 99.999)	-99.99 to 99.999	0.00	2	---	x	x	x		
0010	Power interruption memory	ㄴㄴㄴ	H'00000000: OFF(0), H'00000001: ON(1)	ㄴㄴㄴ, ㄴㄴ	ㄴㄴㄴ	---	---					

Note The values beginning with H' in the *Monitor/Setting range* column are used when setting or monitoring data via communications.

Display Adjustment Level

Variable type	Address	Parameter name	Character	Monitor/Setting range	Character	Default setting	Decimal point	Unit	Model			
									X	V	S	H
C6	0000	Comparative set value display	S _{udSP}	H'00000000: OFF(0), H'00000001: ON(1)	āFF, ān	āFF	---	---				
	0001	Display refresh period	d _{rEF}	H'00000000: OFF(0), H'00000001: 0.5 s(1), H'00000002: 1 s(2), H'00000003: 2 s(3), H'00000004: 4 s(4)	āFF, ā.5, 1, 2, 4	āFF	---	s				
	0002	Display color selection	ēāēā	H'00000000: Green (red)(0), H'00000001: green(1), H'00000002: red (green)(2), H'00000003: red(3)	ērā-r, ērā, rēd-ē, rēd	ērā-r	---	---				
	0003	Display value selection	d _{LS} P	H'00000000: PV(0), H'00000001: MAX(1), H'00000002: MIN (2)	P _u , āP _u , āēn	P _u	---	---				
	0004	Automatic display return	r _{Et}	H'00000000 to H'00000063: (0 to 99)	ā to 99	ā	---	s				
	0005	Position meter type	P _{āS} -ē	H'00000000: OFF(0), H'00000001: increase(1), H'00000002: increase (inverted)(2), H'00000003: deviation (3), H'00000004: deviation, (inverted)(4)	āFF, ēnē, ēnē-r, dēu, dēu-r	ēnē	---	---				
	0006	Position meter upper limit	P _{āS} -H	H'FFFFB1E1 to H'0001869F (-19,999 to 99,999)	-9999 to 99999	X (VD): 9999 X (AD): 9999 X (VA): 4000 X (AA): 10000 V: 9999 S: 99999 H: 1300.0	According to the decimal position setting	---				
	0007	Position meter lower limit	P _{āS} -L	H'FFFFB1E1 to H'0001869F (-19,999 to 99,999)	-9999 to 99999	X (VD): -9999 X (AD): -9999 X (VA): ā X (AA): ā V: ā S: -9999 H: -200.0	According to the decimal position setting	---				
0008	PV decimal point indication	P _{udP}	H'00000000: OFF(0) H'00000001: ON(1)	āFF, ān	ān	---	---	x	x	x		

Note The values beginning with H' in the *Monitor/Setting range* column are used when setting or monitoring data via communications.

Comparative Set Value Level

Variable type	Address	Parameter name	Character	Monitor/Setting range	Character	Default setting	Decimal point	Unit	Model			
									X	V	S	H
C8	0000	Comparative set value 0 HH	S _{uQH}	H'FFFFB1E1 to H'0001869F (-19,999 to 99,999)	-9999 to 99999	99999	According to the decimal position setting	---				
	0001	Comparative set value 0 H	S _{uH}	H'FFFFB1E1 to H'0001869F (-19,999 to 99,999)	-9999 to 99999	99999	According to the decimal position setting	---				
	0002	Comparative set value 0 L	S _{uL}	H'FFFFB1E1 to H'0001869F (-19,999 to 99,999)	-9999 to 99999	-99999	According to the decimal position setting	---				
	0003	Comparative set value 0 LL	S _{uLL}	H'FFFFB1E1 to H'0001869F (-19,999 to 99,999)	-9999 to 99999	-99999	According to the decimal position setting	---				

Variable type	Address	Parameter name	Character	Monitor/Setting range	Character	Default setting	Decimal point	Unit	Model			
									X	V	S	H
C8	0004	Comparative set value 1 HH	5u 1HH	H'FFFFB1E1 to H'0001869F (-19,999 to 99,999)	19999 to 99999	99999	According to the decimal position setting	---				
	0005	Comparative set value 1 H	5u 1H	H'FFFFB1E1 to H'0001869F (-19,999 to 99,999)	19999 to 99999	99999	According to the decimal position setting	---				
	0006	Comparative set value 1 L	5u 1L	H'FFFFB1E1 to H'0001869F (-19,999 to 99,999)	19999 to 99999	19999	According to the decimal position setting	---				
	0007	Comparative set value 1 LL	5u 1LL	H'FFFFB1E1 to H'0001869F (-19,999 to 99,999)	19999 to 99999	19999	According to the decimal position setting	---				
	0008	Comparative set value 2 HH	5u 2HH	H'FFFFB1E1 to H'0001869F (-19,999 to 99,999)	19999 to 99999	99999	According to the decimal position setting	---				
	0009	Comparative set value 2H	5u 2H	H'FFFFB1E1 to H'0001869F (-19,999 to 99,999)	19999 to 99999	99999	According to the decimal position setting	---				
	000A	Comparative set value 2 L	5u 2L	H'FFFFB1E1 to H'0001869F (-19,999 to 99,999)	19999 to 99999	19999	According to the decimal position setting	---				
	000B	Comparative set value 2 LL	5u 2LL	H'FFFFB1E1 to H'0001869F (-19,999 to 99,999)	19999 to 99999	19999	According to the decimal position setting	---				
	000C	Comparative set value 3 HH	5u 3HH	H'FFFFB1E1 to H'0001869F (-19,999 to 99,999)	19999 to 99999	99999	According to the decimal position setting	---				
	000D	Comparative set value 3 H	5u 3H	H'FFFFB1E1 to H'0001869F (-19,999 to 99,999)	19999 to 99999	99999	According to the decimal position setting	---				
	000E	Comparative set value 3 L	5u 3L	H'FFFFB1E1 to H'0001869F (-19,999 to 99,999)	19999 to 99999	19999	According to the decimal position setting	---				
	000F	Comparative set value 3 LL	5u 3LL	H'FFFFB1E1 to H'0001869F (-19,999 to 99,999)	19999 to 99999	19999	According to the decimal position setting	---				
	0010	Comparative set value 4 HH	5u 4HH	H'FFFFB1E1 to H'0001869F (-19,999 to 99,999)	19999 to 99999	99999	According to the decimal position setting	---				
	0011	Comparative set value 4 H	5u 4H	H'FFFFB1E1 to H'0001869F (-19,999 to 99,999)	19999 to 99999	99999	According to the decimal position setting	---				
	0012	Comparative set value 4 L	5u 4L	H'FFFFB1E1 to H'0001869F (-19,999 to 99,999)	19999 to 99999	19999	According to the decimal position setting	---				
	0013	Comparative set value 4 LL	5u 4LL	H'FFFFB1E1 to H'0001869F (-19,999 to 99,999)	19999 to 99999	19999	According to the decimal position setting	---				
0014	Comparative set value 5 HH	5u 5HH	H'FFFFB1E1 to H'0001869F (-19,999 to 99,999)	19999 to 99999	99999	According to the decimal position setting	---					
0015	Comparative set value 5 H	5u 5H	H'FFFFB1E1 to H'0001869F (-19,999 to 99,999)	19999 to 99999	99999	According to the decimal position setting	---					

Variable type	Address	Parameter name	Character	Monitor/Setting range	Character	Default setting	Decimal point	Unit	Model			
									X	V	S	H
C8	0016	Comparative set value 5 L	5.5L	H'FFFFB1E1 to H'0001869F (-19,999 to 99,999)	19999 to 99999	19999	According to the decimal position setting	---				
	0017	Comparative set value 5 LL	5.5LL	H'FFFFB1E1 to H'0001869F (-19,999 to 99,999)	19999 to 99999	19999	According to the decimal position setting	---				
	0018	Comparative set value 6 HH	5.6HH	H'FFFFB1E1 to H'0001869F (-19,999 to 99,999)	19999 to 99999	99999	According to the decimal position setting	---				
	0019	Comparative set value 6 H	5.6H	H'FFFFB1E1 to H'0001869F (-19,999 to 99,999)	19999 to 99999	99999	According to the decimal position setting	---				
	001A	Comparative set value 6 L	5.6L	H'FFFFB1E1 to H'0001869F (-19,999 to 99,999)	19999 to 99999	19999	According to the decimal position setting	---				
	001B	Comparative set value 6 LL	5.6LL	H'FFFFB1E1 to H'0001869F (-19,999 to 99,999)	19999 to 99999	19999	According to the decimal position setting	---				
	001C	Comparative set value 7 HH	5.7HH	H'FFFFB1E1 to H'0001869F (-19,999 to 99,999)	19999 to 99999	99999	According to the decimal position setting	---				
	001D	Comparative set value 7 H	5.7H	H'FFFFB1E1 to H'0001869F (-19,999 to 99,999)	19999 to 99999	99999	According to the decimal position setting	---				
	001E	Comparative set value 7 L	5.7L	H'FFFFB1E1 to H'0001869F (-19,999 to 99,999)	19999 to 99999	19999	According to the decimal position setting	---				
	001F	Comparative set value 7 LL	5.7LL	H'FFFFB1E1 to H'0001869F (-19,999 to 99,999)	19999 to 99999	19999	According to the decimal position setting	---				

Note The values beginning with H' in the *Monitor/Setting range* column are used when setting or monitoring data via communications.

Linear Output Level

Variable type	Address	Parameter name	Character	Monitor/Setting range	Character	Default setting	Decimal point	Unit	Model			
									X	V	S	H
C9	0000	Linear current type	L5EtL	H'00000000: 0 to 20 mA(0), H'00000001: 4 to 20 mA(1)	0-20, 4-20	4-20	---	---				
	0001	Linear voltage type	L5EtV	H'00000000: 0 to 5 V(0), H'00000001: 1 to 5 V(1), H'00000002: 0 to 10 V(2)	0-5, 1-5, 0-10	1-5	---	---				
	0002	Linear output upper limit	L5EtH	H'FFFFB1E1 to H'0001869F (-19,999 to 99,999)	19999 to 99999	X (VD): 19999 X (AD): 19999 X (VA): 40000 X (AA): 10000 V: 19999 S: 99999 H: 1300.0	According to the decimal position setting	---				
	0003	Linear output lower limit	L5EtL	H'FFFFB1E1 to H'0001869F (-19,999 to 99,999)	19999 to 99999	X (VD): 19999 X (AD): 19999 X (VA): 0 X (AA): 0 V: 0 S: 19999 H: -200.0	According to the decimal position setting	---				

Note The values beginning with H' in the *Monitor/Setting range* column are used when setting or monitoring data via communications.

Communications Setting Level

Variable type	Address	Parameter name	Character	Monitor/Setting range	Character	Default setting	Decimal point	Unit	Model			
									X	V	S	H
CA	0000	Unit No.	U-nō	H'00000000 to H'00000063: (0 to 99)	U to 99	!	---	---				
	0001	Baud rate	bPS	H'00000000: 9.6(0), H'00000001: 19.2(1), H'00000002: 38.4(2)	9.6, 19.2, 38.4	9.6	---	kbps				
	0002	Data length	LEN	H'00000000: 7(0), H'00000001: 8(1)	7, 8	7	---	bit				
	0003	Stop bit length	SbL	H'00000000: 1(0), H'00000001: 2(1)	1, 2	2	---	bit				
	0004	Parity	PrL	H'00000000: None (0), H'00000001: Even (1), H'00000002: Odd (2)	nōnE, Euen, odd	Euen	---	---				
	0005	Send wait time	SdWt	H'00000000 to H'00000063 (0 to 99)	U to 99	2U	---	ms				

Note The values beginning with H' in the *Monitor/Setting range* column are used when setting or monitoring data via communications.

Advanced Function Setting Level

Variable type	Address	Parameter name	Character	Monitor/Setting range	Character	Default setting	Decimal point	Unit	Model			
									X	V	S	H
CB	0000	PASS-output change	PR55	H'00000000: LL(0), H'00000001: L(1), H'00000002: PASS(2), H'00000003: H(3), H'00000004: HH(4), H'00000005: ERR(5)	LL, L, PR55, H, HH, Err	PR55	---	---				
	0001	Hysteresis	HY5	H'00000000 to H'0000270F: (0 to 9,999)	U to 9999	!	According to the decimal position setting	---				
	0002	Output OFF delay	OFF-d	H'00000000 to H'000007CF (0 to 1,999)	U to 1999	U	---	S: ms Others: 100 ms				
	0003	Shot output	SHōt	H'00000000 to H'000007CF (0 to 1,999)	U to 1999	U	---	S: ms Others: 100 ms				
	0004	Output logic	ōtL-n	H'00000000: Close in alarm(0), H'00000001: Open in alarm(1)	n-ō, n-L	n-ō	---	---				
	0005	Output refresh stop	ō-SōP	H'00000000: OFF(0), H'00000001: OUT(1), H'00000002: ALL(2)	ōFF, ōtL, RL L	ōFF	---	---				
	0006	Tare zero	t-zō	H'00000000: OFF(0) H'00000001: ON(1)	ōFF, ōn	ōFF	---	---				x
	0007	Zero trimming	z-tōn	H'00000000: OFF(0) H'00000001: ON(1)	ōFF, ōn	ōFF	---	---				x
	0008	Previous average value comparison	HP-F	H'00000000: OFF(0) H'00000001: ON(1)	ōFF, ōn	ōFF	---	---				
	0009	Bank selection	bōn-P-L	H'00000000: OFF(0), H'00000001: KEY(1), H'00000002: EV(2)	ōFF, PLY, E u	ōFF (See note.)	---	---				
	000A	Startup compensation timer	S-tōn	H'00000000 to H'0000270F: (0 to 99.9)	U . U to 99 . 9	U . U	1	s				
	000B	Input error enable	SErr	H'00000000: Disable(0), H'00000001: overflow(1), H'00000002: input error(2)	ōFF, ōuEr, SErr	SErr	---	---				
	000C	Standby sequence	Sōt dōbL	H'00000000: OFF(0) H'00000001: ON(1)	ōFF, ōn	ōFF	---	---				
	000D	Cold junction compensating circuit	L-L	H'00000000: OFF(0) H'00000001: ON(1)	ōFF, ōn	ōn	---	---	x	x	x	

Note (1) The values beginning with H' in the *Monitor/Setting range* column are used when setting or monitoring data via communications.

(2) If the event connector is provided as a standard feature or an event connector is added, use EV for the "bank selection" setting.

K3HB-R/P

Communications Monitoring Settings

Variable type	Address	Parameter name	Character	Monitor/Setting range	Character	Default setting	Decimal point	Unit
C0	0000	Version	---	---	---	---	---	---
	0001	Status	---	---	---	---	---	---
	0002	Measurement value	---	H'FFFFB1E1 to H'0001869F: -19999 to 99999 (Time limit is OFF. Lower limit of P is 0.) H'00000000 to H'0001869F: 0 to 99999 (Time unit is min.) H'00000000 to H'000176D7: 0.00.00 to 9.59.59 (Time unit is hr:min:s.) H'00000000 to H'0001850F: 00.00.0 to 99.59.9 (Time unit is min:s.ms.)	---	---	---	---
	0003	Max. value	---	Same as above	---	---	---	---
	0004	Min. value	---	Same as above	---	---	---	---

Note The values beginning with H' in the *Monitor/Setting range* column are used when setting or monitoring data via communications.

Protect Level

Variable type	Address	Parameter name	Character	Monitor/Setting range	Character	Default setting	Decimal point	Unit
C1	0000	RUN/adjustment protect	~Δ.Pk	H'00000000 to H'00000002: (0 to 2)	0 to 2	0	---	---
	0001	Setting level protect	SE.Pk	H'00000000 to H'00000002: (0 to 2)	0 to 2	1	---	---
	0002	Setting change protect	Δ.Pk	H'00000000: OFF (0) H'00000001: ON (1)	0FF, 0n	0FF	---	---
	0003	Max/Min protect	ΔΔ.Pk	H'00000000 to H'00000002: (0 to 2)	0 to 2	0	---	---

Note The values beginning with H' in the *Monitor/Setting range* column are used when setting or monitoring data via communications.

RUN Level

Variable type	Address	Parameter name	Character	Monitor/Setting range	Character	Default setting	Decimal point	Unit
C2	0000	Measurement value/comparative set value HH	---	H'FFFFB1E1 to H'0001869F: -19999 to 99999 (Time limit is OFF. Lower limit of P is 0.) H'00000000 to H'0001869F: 0 to 99999 (Time unit is min.) H'00000000 to H'000176D7: 0.00.00 to 9.59.59 (Time unit is hr:min:s.) H'00000000 to H'0001850F: 00.00.0 to 99.59.9 (Time unit is min:s.ms.)	19999 to 99999 0.00.00 to 99999 0.00.00 to 9.59.59 0.00.00 to 99.59.9	99999	According to the decimal position setting. The time unit, however, is indicated as *.*.* for hr:min:s and as *.*.* for min:s.ms.	---
	0001	Measurement value/comparative set value H	---	Same as above	Same as above	99999	Same as above	---
	0002	Measurement value/comparative set value L	---	Same as above	Same as above	R: 19999 P: 0	Same as above	---
	0003	Measurement value/comparative set value LL	---	Same as above	Same as above	R: 19999 P: 0	Same as above	---

Note The values beginning with H' in the *Monitor/Setting range* column are used when setting or monitoring data via communications.

Display Adjustment Level

Variable type	Address	Parameter name	Character	Monitor/Setting range	Character	Default setting	Decimal point	Unit
C6	0000	Comparative set value display	Su.d5P	H'00000000: OFF (0), H'00000001: ON (1)	oFF, on	oFF	---	---
	0001	Display refresh period	d.rEF	H'00000000: OFF (0), H'00000001: 0.5 s (1), H'00000002: 1 s (2), H'00000003: 2 s (3), H'00000004: 4 s (4)	oFF, 0.5, 1, 2, 4	oFF	---	s
	0002	Display color selection	Eol.or	H'00000000: Green (red) (0), H'00000001: Green (1), H'00000002: Red (green) (2), H'00000003: Red (3)	Grn-r, Grn, rEd-G, rEd	Grn-r	---	---
	0003	Display value selection	d.SP	H'00000000: PV (0), H'00000001: Max (1), H'00000002: Min (2)	Pu, nPu, nLn	Pu	---	---
	0004	Automatic display return	rEt	H'00000000 to H'00000063: (0 to 99)	0 to 99	!0	---	s
	0005	Position meter type	Po5-t	H'00000000: OFF (0), H'00000001: Incremental (1), H'00000002: Incremental (reversed) (2), H'00000003: Deviation (3), H'00000004: Deviation (reversed) (4)	oFF, LnL, LnL-r, dEu, dEu-r	LnL	---	---
	0006	Position meter upper limit	Po5-H	H'FFFFB1E1 to H'0001869F: -19999 to 99999 (Time limit is OFF. Lower limit of P is 0.) H'00000000 to H'0001869F: 0 to 99999 (Time unit is min.) H'00000000 to H'000176D7: 0.00.00 to 9.59.59 (Time unit is hr:min:s.) H'00000000 to H'0001850F: 00.00.0 to 99.59.9 (Time unit is min:s.ms.)	-9999 to 99999 0.00.00 to 99999 0.00.00 to 9.59.59 00.00.0 to 99.59.9	99999	According to the decimal position setting. The time unit, however, is indicated as *.**.* for hr:min:s and as **.**. for min:s.ms.	---
	0007	Position meter lower limit	Po5-L	Same as above	Same as above	R: 9999 P: 0	Same as above	---

Note The values beginning with H' in the *Monitor/Setting range* column are used when setting or monitoring data via communications.

Prescale Level

Variable type	Address	Parameter name	Character	Monitor/Setting range	Character	Default setting	Decimal point	Unit
C7	0000	Prescale 0AX	P50.R0	H'00000000 to H'0001869F: (0.0000 to 9.9999)	0.0000 to 9.9999	1.0000	4	---
	0001	Prescale 0AY	P50.R1	H'FFFFFFF7 to H'00000009: (-9 to 9)	10 -9 to 10 9	10 0	---	---
	0002	Prescale 0BX	P50.b0	H'00000000 to H'0001869F: (0.0000 to 9.9999)	0.0000 to 9.9999	1.0000	4	---
	0003	Prescale 0BY	P50.b1	H'FFFFFFF7 to H'00000009: (-9 to 9)	10 -9 to 10 9	10 0	---	---
	0004	Decimal point position 0	dP0	H'00000000 to H'00000004: (0 to 4)	0.0000, 0.000.0, 0.00.00, 0.0.000, 0.0000	0.0000	---	---
	0005	Prescale 1AX	P51.R0	H'00000000 to H'0001869F: (0.0000 to 9.9999)	0.0000 to 9.9999	1.0000	4	---
	0006	Prescale 1AY	P51.R1	H'FFFFFFF7 to H'00000009: (-9 to 9)	10 -9 to 10 9	10 0	---	---
	0007	Prescale 1BX	P51.b0	H'00000000 to H'0001869F: (0.0000 to 9.9999)	0.0000 to 9.9999	1.0000	4	---
	0008	Prescale 1BY	P51.b1	H'FFFFFFF7 to H'00000009: (-9 to 9)	10 -9 to 10 9	10 0	---	---
	0009	Decimal point position 1	dP1	H'00000000 to H'00000004: (0 to 4)	0.0000, 0.000.0, 0.00.00, 0.0.000, 0.0000	0.0000	---	---
	000A	Prescale 2AX	P52.R0	H'00000000 to H'0001869F: (0.0000 to 9.9999)	0.0000 to 9.9999	1.0000	4	---
	000B	Prescale 2AY	P52.R1	H'FFFFFFF7 to H'00000009: (-9 to 9)	10 -9 to 10 9	10 0	---	---
	000C	Prescale 2BX	P52.b0	H'00000000 to H'0001869F: (0.0000 to 9.9999)	0.0000 to 9.9999	1.0000	4	---
	000D	Prescale 2BY	P52.b1	H'FFFFFFF7 to H'00000009: (-9 to 9)	10 -9 to 10 9	10 0	---	---
	000E	Decimal point position 2	dP2	H'00000000 to H'00000004: (0 to 4)	0.0000, 0.000.0, 0.00.00, 0.0.000, 0.0000	0.0000	---	---
	000F	Prescale 3AX	P53.R0	H'00000000 to H'0001869F: (0.0000 to 9.9999)	0.0000 to 9.9999	1.0000	4	---
	0010	Prescale 3AY	P53.R1	H'FFFFFFF7 to H'00000009: (-9 to 9)	10 -9 to 10 9	10 0	---	---
	0011	Prescale 3BX	P53.b0	H'00000000 to H'0001869F: (0.0000 to 9.9999)	0.0000 to 9.9999	1.0000	4	---
	0012	Prescale 3BY	P53.b1	H'FFFFFFF7 to H'00000009: (-9 to 9)	10 -9 to 10 9	10 0	---	---
	0013	Decimal point position 3	dP3	H'00000000 to H'00000004: (0 to 4)	0.0000, 0.000.0, 0.00.00, 0.0.000, 0.0000	0.0000	---	---
	0014	Prescale 4AX	P54.R0	H'00000000 to H'0001869F: (0.0000 to 9.9999)	0.0000 to 9.9999	1.0000	4	---
	0015	Prescale 4AY	P54.R1	H'FFFFFFF7 to H'00000009: (-9 to 9)	10 -9 to 10 9	10 0	---	---
	0016	Prescale 4BX	P54.b0	H'00000000 to H'0001869F: (0.0000 to 9.9999)	0.0000 to 9.9999	1.0000	4	---
	0017	Prescale 4BY	P54.b1	H'FFFFFFF7 to H'00000009: (-9 to 9)	10 -9 to 10 9	10 0	---	---
	0018	Decimal point position 4	dP4	H'00000000 to H'00000004: (0 to 4)	0.0000, 0.000.0, 0.00.00, 0.0.000, 0.0000	0.0000	---	---
	0019	Prescale 5AX	P55.R0	H'00000000 to H'0001869F: (0.0000 to 9.9999)	0.0000 to 9.9999	1.0000	4	---
	001A	Prescale 5AY	P55.R1	H'FFFFFFF7 to H'00000009: (-9 to 9)	10 -9 to 10 9	10 0	---	---
001B	Prescale 5BX	P55.b0	H'00000000 to H'0001869F: (0.0000 to 9.9999)	0.0000 to 9.9999	1.0000	4	---	
001C	Prescale 5BY	P55.b1	H'FFFFFFF7 to H'00000009: (-9 to 9)	10 -9 to 10 9	10 0	---	---	
001D	Decimal point position 5	dP5	H'00000000 to H'00000004: (0 to 4)	0.0000, 0.000.0, 0.00.00, 0.0.000, 0.0000	0.0000	---	---	
001E	Prescale 6AX	P56.R0	H'00000000 to H'0001869F: (0.0000 to 9.9999)	0.0000 to 9.9999	1.0000	4	---	
001F	Prescale 6AY	P56.R1	H'FFFFFFF7 to H'00000009: (-9 to 9)	10 -9 to 10 9	10 0	---	---	
0020	Prescale 6BX	P56.b0	H'00000000 to H'0001869F: (0.0000 to 9.9999)	0.0000 to 9.9999	1.0000	4	---	
0021	Prescale 6BY	P56.b1	H'FFFFFFF7 to H'00000009: (-9 to 9)	10 -9 to 10 9	10 0	---	---	
0022	Decimal point position 6	dP6	H'00000000 to H'00000004: (0 to 4)	0.0000, 0.000.0, 0.00.00, 0.0.000, 0.0000	0.0000	---	---	
0023	Prescale 7AX	P57.R0	H'00000000 to H'0001869F: (0.0000 to 9.9999)	0.0000 to 9.9999	1.0000	4	---	
0024	Prescale 7AY	P57.R1	H'FFFFFFF7 to H'00000009: (-9 to 9)	10 -9 to 10 9	10 0	---	---	
0025	Prescale 7BX	P57.b0	H'00000000 to H'0001869F: (0.0000 to 9.9999)	0.0000 to 9.9999	1.0000	4	---	
0026	Prescale 7BY	P57.b1	H'FFFFFFF7 to H'00000009: (-9 to 9)	10 -9 to 10 9	10 0	---	---	
0027	Decimal point position 7	dP7	H'00000000 to H'00000004: (0 to 4)	0.0000, 0.000.0, 0.00.00, 0.0.000, 0.0000	0.0000	---	---	

Note The values beginning with H' in the *Monitor/Setting range* column are used when setting or monitoring data via communications.

Comparative Set Value Level

Variable type	Address	Parameter name	Character	Monitor/Setting range	Character	Default setting	Decimal point	Unit
C8	0000	Comparative set value 0HH	5u0.HH	H'FFFFB1E1 to H'0001869F: -19999 to 99999 (Time limit is OFF. Lower limit of P is 0.) H'00000000 to H'0001869F: 0 to 99999 (Time unit is min.) H'00000000 to H'000176D7: 0.00.00 to 9.59.59 (Time unit is hr:min:s.) H'00000000 to H'0001850F: 00.00.0 to 99.59.9 (Time unit is min:s.ms.)	19999 to 99999 0.00.00 to 99999 0.00.00 to 9.59.59 0.00.00 to 99.59.9	99999	According to the decimal position setting. The time unit, however, is indicated as **.* for hr:min:s and as *.*.* for min:s.ms.	---
	0001	Comparative set value 0H	5u0.H	Same as above	Same as above	99999	Same as above	---
	0002	Comparative set value 0L	5u0.L	Same as above	Same as above	R: 19999 P: 0	Same as above	---
	0003	Comparative set value 0LL	5u0.LL	Same as above	Same as above	R: 19999 P: 0	Same as above	---
	0004	Comparative set value 1HH	5u1.HH	Same as above	Same as above	99999	Same as above	---
	0005	Comparative set value 1H	5u1.H	Same as above	Same as above	99999	Same as above	---
	0006	Comparative set value 1L	5u1.L	Same as above	Same as above	R: 19999 P: 0	Same as above	---
	0007	Comparative set value 1LL	5u1.LL	Same as above	Same as above	R: 19999 P: 0	Same as above	---
	0008	Comparative set value 2HH	5u2.HH	Same as above	Same as above	99999	Same as above	---
	0009	Comparative set value 2H	5u2.H	Same as above	Same as above	99999	Same as above	---
	000A	Comparative set value 2L	5u2.L	Same as above	Same as above	R: 19999 P: 0	Same as above	---
	000B	Comparative set value 2LL	5u2.LL	Same as above	Same as above	R: 19999 P: 0	Same as above	---
	000C	Comparative set value 3HH	5u3.HH	Same as above	Same as above	99999	Same as above	---
	000D	Comparative set value 3H	5u3.H	Same as above	Same as above	99999	Same as above	---
	000E	Comparative set value 3L	5u3.L	Same as above	Same as above	R: 19999 P: 0	Same as above	---
	000F	Comparative set value 3LL	5u3.LL	Same as above	Same as above	R: 19999 P: 0	Same as above	---
	0010	Comparative set value 4HH	5u4.HH	Same as above	Same as above	99999	Same as above	---
	0011	Comparative set value 4H	5u4.H	Same as above	Same as above	99999	Same as above	---
	0012	Comparative set value 4L	5u4.L	Same as above	Same as above	R: 19999 P: 0	Same as above	---
	0013	Comparative set value 4LL	5u4.LL	Same as above	Same as above	R: 19999 P: 0	Same as above	---
	0014	Comparative set value 5HH	5u5.HH	Same as above	Same as above	99999	Same as above	---
	0015	Comparative set value 5H	5u5.H	Same as above	Same as above	99999	Same as above	---
	0016	Comparative set value 5L	5u5.L	Same as above	Same as above	R: 19999 P: 0	Same as above	---
	0017	Comparative set value 5LL	5u5.LL	Same as above	Same as above	R: 19999 P: 0	Same as above	---
	0018	Comparative set value 6HH	5u6.HH	Same as above	Same as above	99999	Same as above	---
	0019	Comparative set value 6H	5u6.H	Same as above	Same as above	99999	Same as above	---
	001A	Comparative set value 6L	5u6.L	Same as above	Same as above	R: 19999 P: 0	Same as above	---
	001B	Comparative set value 6LL	5u6.LL	Same as above	Same as above	R: 19999 P: 0	Same as above	---
001C	Comparative set value 7HH	5u7.HH	Same as above	Same as above	99999	Same as above	---	
001D	Comparative set value 7H	5u7.H	Same as above	Same as above	99999	Same as above	---	
001E	Comparative set value 7L	5u7.L	Same as above	Same as above	R: 19999 P: 0	Same as above	---	
001F	Comparative set value 7LL	5u7.LL	Same as above	Same as above	R: 19999 P: 0	Same as above	---	

Linear Output Level

Variable type	Address	Parameter name	Character	Monitor/Setting range	Character	Default setting	Decimal point	Unit
C9	0000	Linear current type	ᐱ5ᐸᐸ.ᐸ	H'00000000: 0-20 mA (0), H'00000001: 4-20 mA (1)	ᐸ-2ᐸ, 4-2ᐸ	4-2ᐸ	---	---
	0001	Linear voltage type	ᐱ5ᐸᐸ.ᐸ	H'00000000: 0-5 V (0), H'00000001: 1-5 V (1), H'00000002: 0-10 V (2)	ᐸ-5, 1-5, ᐸ-1ᐸ	1-5	---	---
	0002	Linear output upper limit	ᐱ5ᐸᐸ.ᐸ	H'FFFFB1E1 to H'0001869F: -19999 to 99999 (Time limit is OFF. Lower limit of P is 0.) H'00000000 to H'0001869F: 0 to 99999 (Time unit is min.) H'00000000 to H'000176D7: 0.00.00 to 9.59.59 (Time unit is hr:min:s.) H'00000000 to H'0001850F: 00.00.0 to 99.59.9 (Time unit is min:s.ms.)	19999 to 99999 ᐸ.ᐸᐸ.ᐸᐸ to 99999 ᐸ.ᐸᐸ.ᐸᐸ to 9.59.59 ᐸ.ᐸᐸ.ᐸᐸ to 99.59.9	99999	According to the decimal position setting. The time unit, however, is indicated as *.*.* for hr:min:s and as *.*.*.* for min:s.ms.	---
	0003	Linear output lower limit	ᐱ5ᐸᐸ.ᐱ	Same as above	Same as above	R: 19999 P: ᐸ	Same as above	---

Note The values beginning with H' in the *Monitor/Setting range* column are used when setting or monitoring data via communications.

Communications Setting Level

Variable type	Address	Parameter name	Character	Monitor/Setting range	Character	Default setting	Decimal point	Unit
CA	0000	Communications unit number	ᐱ-ᐱᐸ	H'00000000 to H'00000063: (0 to 99)	ᐸ to 99	1	---	---
	0001	Baud rate	ᐱᐸ5	H'00000000: 9.6 (0), H'00000001: 19.2 (1), H'00000002: 38.4 (2)	ᐸ.6, 19.2, 38.4	ᐸ.6	---	kbps
	0002	Communications data length	ᐱᐸᐱ	H'00000000: 7 (0), H'00000001: 8 (1)	7, 8	7	---	bit
	0003	Communications stop bits	ᐱᐸᐸ	H'00000000: 1 (0), H'00000001: 2 (1)	1, 2	2	---	bit
	0004	Communications parity	ᐱᐸᐸᐸ	H'00000000: None (0), H'00000001: Even (1), H'00000002: Odd (2)	ᐱᐸᐱᐸ, ᐸᐸᐸᐸ, ᐸᐸᐸᐸ	ᐸᐸᐸᐸ	---	---
	0005	Send wait time	ᐱᐸᐸᐸ	H'00000000 to H'00000063: (0 to 99)	ᐸ to 99	2ᐸ	---	ms

Note The values beginning with H' in the *Monitor/Setting range* column are used when setting or monitoring data via communications.

Advanced Function Setting Level

Variable type	Address	Parameter name	Character	Monitor/Setting range	Character	Default setting	Decimal point	Unit
CB	0000	PASS output change	ᐱᐸ55	H'00000000: LL (0), H'00000001: L (1), H'00000002: PASS (2), H'00000003: H (3), H'00000004: HH (4)	ᐱ.ᐱ, ᐱ, ᐱᐸ55, ᐸ, ᐸᐸ	ᐱᐸ55	---	---
	0001	Hysteresis	ᐼᐸ5	H'00000000 to H'0000270F: 0 to 9999 (Time limit is OFF. Lower limit of P is 0.) H'00000000 to H'00001747: 0.00.00 to 0.59.59 (Time unit is hr:min:s.) H'00000000 to H'0000257F: 00.00.0 to 09.59.9 (Time unit is min:s.ms.)	ᐸ to 9999 ᐸ.ᐸᐸ.ᐸᐸ to ᐸ.59.59 ᐸᐸ.ᐸᐸ.ᐸ to ᐸ9.59.9	1	According to the decimal position setting. The time unit, however, is indicated as *.*.*.* for hr:min:s and as *.*.*.*.* for min:s.ms.	---
	0002	Output OFF delay	ᐼᐸᐸ-ᐸ	H'00000000 to H'000007CF: (0 to 1999)	ᐸ to 1999	ᐸ	---	R: 100 ms P: ms
	0003	Shot output	ᐼᐸᐸᐸ	H'00000000 to H'000007CF: (0 to 1999)	ᐸ to 1999	ᐸ	---	R: 100 ms P: ms
	0004	Output logic	ᐼᐸᐸ-ᐱ	H'00000000: Close in alarm (0), H'00000001: Open in alarm (1)	ᐱ-ᐼ, ᐱ-ᐸ	ᐱ-ᐼ	---	---
	0005	Output refresh stop	ᐼ-5ᐸᐸᐸ	H'00000000: OFF (0), H'00000001: OUT (1), H'00000002: ALL (2)	ᐼᐸᐸᐸ, ᐼᐸᐸᐸ, ᐼᐱᐱ	ᐼᐸᐸᐸ	---	---
	0009	Bank selection	ᐼᐱᐸ-ᐸ	H'00000000: OFF (0), H'00000001: KEY (1), H'00000002: EV (2)	ᐼᐸᐸᐸ, ᐼᐸᐸᐸ, ᐸᐸ	ᐼᐸᐸᐸ (See note 1.)	---	---
	000A	Startup compensation timer	ᐼ-ᐸᐼᐼ	H'00000000 to H'0000270F: (0.0 to 99.9)	ᐸ.ᐸ to 99.9	ᐸ.ᐸ	1	s
	000C	Standby sequence	ᐼᐸᐸᐸᐸ	H'00000000: OFF (0), H'00000001: ON (1)	ᐼᐸᐸᐸ, ᐼᐱ	ᐼᐸᐸᐸ	---	---

Note (1) If the event connector is provided as a standard feature or an event connector is added, use EV for the “bank selection” set.
(2) The values beginning with H' in the *Monitor/Setting range* column are used when setting or monitoring data via communications.

K3HB-C**Communications Monitoring Settings**

Variable type	Address	Parameter name	Character	Monitor/Setting range	Character	Default setting	Decimal point	Unit
C0	0000	Version	---	---	---	---	---	---
	0001	Status	---	---	---	---	---	---
	0002	Measurement value	---	H'FFFFFFB1E1 to H'0001869F: (-19999 to 99999)	---	---	---	---
	0003	Max. value	---	H'FFFFFFB1E1 to H'0001869F: (-19999 to 99999)	---	---	---	---
	0004	Min. value	---	H'FFFFFFB1E1 to H'0001869F: (-19999 to 99999)	---	---	---	---

Note The values beginning with H' in the *Monitor/Setting range* column are used when setting or monitoring data via communications.

Protect Level

Variable type	Address	Parameter name	Character	Monitor/Setting range	Character	Default setting	Decimal point	Unit
C1	0000	RUN/adjustment protect	rUn. PŁ	H'00000000 to H'00000002: (0 to 2)	0 to 2	0	---	---
	0001	Setting level protect	SEŁ. PŁ	H'00000000 to H'00000002: (0 to 2)	0 to 2	1	---	---
	0002	Setting change protect	YŁ. PŁ	H'00000000: OFF (0) H'00000001: ON (1)	0FF, 0n	0FF	---	---
	0003	Max/Min protect	nŁ. PŁ	H'00000000 to H'00000002: (0 to 2)	0 to 2	0	---	---

Note The values beginning with H' in the *Monitor/Setting range* column are used when setting or monitoring data via communications.

RUN Level

Variable type	Address	Parameter name	Character	Monitor/Setting range	Character	Default setting	Decimal point	Unit
C2	0000	Measurement value/comparative set value 5	---	H'FFFFFFB1E1 to H'0001869F: (-19999 to 99999)	+9999 to 99999	99999	According to the decimal position setting.	---
	0001	Measurement value/comparative set value 4	---	H'FFFFFFB1E1 to H'0001869F: (-19999 to 99999)	+9999 to 99999	99999	According to the decimal position setting.	---
	0004	Measurement value/comparative set value 3	---	H'FFFFFFB1E1 to H'0001869F: (-19999 to 99999)	+9999 to 99999	99999	According to the decimal position setting.	---
	0002	Measurement value/comparative set value 2	---	H'FFFFFFB1E1 to H'0001869F: (-19999 to 99999)	+9999 to 99999	99999	According to the decimal position setting.	---
	0003	Measurement value/comparative set value 1	---	H'FFFFFFB1E1 to H'0001869F: (-19999 to 99999)	+9999 to 99999	99999	According to the decimal position setting.	---

Note The values beginning with H' in the *Monitor/Setting range* column are used when setting or monitoring data via communications.

Initial Setting Level

Variable type	Address	Parameter name	Character	Monitor/Setting range	Character	Default setting	Decimal point	Unit
C4	0010	Function	F _{UN}	H'00000000: Individual inputs (0), H'00000001: Phase differential inputs (1), H'00000002: Pulse counting input (2)	F 1, F2, F3	F3	---	---
	0001	Input type A	UN- _{AR}	H'00000000: No-contact (NO), H'00000001: No-contact (NC), H'00000002: Contact (NO), H'00000003: Contact (NC)	00, 0 1, 10, 11	00	---	---
	0007	Input type B	UN- _{BR}	H'00000000: No-contact (NO), H'00000001: No-contact (NC), H'00000002: Contact (NO), H'00000003: Contact (NC)	00, 0 1, 10, 11	00	---	---
	0011	Prescale X	P5. _{RU}	H'00000000 to H'0001869F: (0.0000 to 9.9999)	0.0000 to 9.9999	1.0000	4	---
	0012	Prescale Y	P5. _{RY}	H'FFFFFFF7 to H'00000009: (-9 to 9)	10 -9 to 10 9	10 0	---	---
	000D	Decimal point position	dP	H'00000000 to H'00000004: (0 to 4)	00000, 0000.0, 000.00, 00.000, 0.0000	00000	---	---
	000E	Comparative output pattern	o _{UT} -P	H'00000001: Zone outputs (1), H'00000002: Level outputs (2)	o _{onE} , i _{EvE} L	i _{EvE} L	---	---

Note The values beginning with H' in the *Monitor/Setting range* column are used when setting or monitoring data via communications.

Input Adjustment Level

Variable type	Address	Parameter name	Character	Monitor/Setting range	Character	Default setting	Decimal point	Unit
C5	000E	Compensation value	E _o nP _n	H'FFFFFFB1E1 to H'0001869F: (-19999 to 99999)	-19999 to 99999	0	---	---
	000F	Compensation conditions	E _o n-P	H'00000000: None (0), H'00000001: When input is addition (1)	no _{nE} , P _L U5	no _{nE}	---	---
	0010	Power supply memory	n _E o _n	H'00000000: OFF (0), H'00000001: ON (1)	oFF, o _n	oFF	---	---

Note The values beginning with H' in the *Monitor/Setting range* column are used when setting or monitoring data via communications.

Display Adjustment Level

Variable type	Address	Parameter name	Character	Monitor/Setting range	Character	Default setting	Decimal point	Unit
C6	0000	Comparative set value display	S _u . dSP	H'00000000: OFF (0), H'00000001: ON (1)	oFF, o _n	oFF	---	---
	0001	Display refresh period	d. rEF	H'00000000: OFF (0), H'00000001: 0.5 s (1), H'00000002: 1 s (2), H'00000003: 2 s (3), H'00000004: 4 s (4)	oFF, 0.5, 1, 2, 4	oFF	---	s
	0002	Display color selection	E _o i. o _r	H'00000000: Green (red) (0), H'00000001: Green (1), H'00000002: Red (green) (2), H'00000003: Red (3)	o _r o _r -r, o _r o _n , rEd-o _r , rEd	o _r o _r -r	---	---
	0003	Display value selection	d _U S _P	H'00000000: PV (0), H'00000001: Max (1), H'00000002: Min (2)	P _u , n _{RU} , n _U n	P _u	---	---
	0004	Automatic display return	rEt	H'00000000 to H'00000063: (0 to 99)	0 to 99	10	---	s
	0005	Position meter type	P _o S-t	H'00000000: OFF (0), H'00000001: Incremental (1), H'00000002: Incremental (reversed) (2), H'00000003: Deviation (3), H'00000004: Deviation (reversed) (4)	oFF, i _n E, i _n E-r, dE _u , dE _u -r	i _n E	---	---
	0006	Position meter upper limit	P _o S-H	H'FFFFFFB1E1 to H'0001869F: (-19999 to 99999)	-19999 to 99999	99999	---	---
	0007	Position meter lower limit	P _o S-L	H'FFFFFFB1E1 to H'0001869F: (-19999 to 99999)	-19999 to 99999	-19999	---	---

Note The values beginning with H' in the *Monitor/Setting range* column are used when setting or monitoring data via communications.

Prescale Level

Variable type	Address	Parameter name	Character	Monitor/Setting range	Character	Default setting	Decimal point	Unit
C7	0000	Prescale 0X	P50.R	H'00000000 to H'0001869F: (0.0000 to 9.9999)	0.0000 to 9.9999	1.0000	4	---
	0001	Prescale 0Y	P50.RY	H'FFFFFFF7 to H'00000009: (-9 to 9)	10 -9 to 10 9	10 0	---	---
	0004	Decimal point position 0	dP0	H'00000000 to H'00000004: (0 to 4)	0.0000, 0.000.0, 0.00.00, 0.0.000, 0.0000	0.0000	---	---
	0005	Prescale 1X	P51.R	H'00000000 to H'0001869F: (0.0000 to 9.9999)	0.0000 to 9.9999	1.0000	4	---
	0006	Prescale 1Y	P51.RY	H'FFFFFFF7 to H'00000009: (-9 to 9)	10 -9 to 10 9	10 0	---	---
	0009	Decimal point position 1	dP1	H'00000000 to H'00000004: (0 to 4)	0.0000, 0.000.0, 0.00.00, 0.0.000, 0.0000	0.0000	---	---
	000A	Prescale 2X	P52.R	H'00000000 to H'0001869F: (0.0000 to 9.9999)	0.0000 to 9.9999	1.0000	4	---
	000B	Prescale 2Y	P52.RY	H'FFFFFFF7 to H'00000009: (-9 to 9)	10 -9 to 10 9	10 0	---	---
	000E	Decimal point position 2	dP2	H'00000000 to H'00000004: (0 to 4)	0.0000, 0.000.0, 0.00.00, 0.0.000, 0.0000	0.0000	---	---
	000F	Prescale 3X	P53.R	H'00000000 to H'0001869F: (0.0000 to 9.9999)	0.0000 to 9.9999	1.0000	4	---
	0010	Prescale 3Y	P53.RY	H'FFFFFFF7 to H'00000009: (-9 to 9)	10 -9 to 10 9	10 0	---	---
	0013	Decimal point position 3	dP3	H'00000000 to H'00000004: (0 to 4)	0.0000, 0.000.0, 0.00.00, 0.0.000, 0.0000	0.0000	---	---
	0014	Prescale 4X	P54.R	H'00000000 to H'0001869F: (0.0000 to 9.9999)	0.0000 to 9.9999	1.0000	4	---
	0015	Prescale 4Y	P54.RY	H'FFFFFFF7 to H'00000009: (-9 to 9)	10 -9 to 10 9	10 0	---	---
	0018	Decimal point position 4	dP4	H'00000000 to H'00000004: (0 to 4)	0.0000, 0.000.0, 0.00.00, 0.0.000, 0.0000	0.0000	---	---
	0019	Prescale 5X	P55.R	H'00000000 to H'0001869F: (0.0000 to 9.9999)	0.0000 to 9.9999	1.0000	4	---
	001A	Prescale 5Y	P55.RY	H'FFFFFFF7 to H'00000009: (-9 to 9)	10 -9 to 10 9	10 0	---	---
	001D	Decimal point position 5	dP5	H'00000000 to H'00000004: (0 to 4)	0.0000, 0.000.0, 0.00.00, 0.0.000, 0.0000	0.0000	---	---
	001E	Prescale 6X	P56.R	H'00000000 to H'0001869F: (0.0000 to 9.9999)	0.0000 to 9.9999	1.0000	4	---
	001F	Prescale 6Y	P56.RY	H'FFFFFFF7 to H'00000009: (-9 to 9)	10 -9 to 10 9	10 0	---	---
0022	Decimal point position 6	dP6	H'00000000 to H'00000004: (0 to 4)	0.0000, 0.000.0, 0.00.00, 0.0.000, 0.0000	0.0000	---	---	
0023	Prescale 7X	P57.R	H'00000000 to H'0001869F: (0.0000 to 9.9999)	0.0000 to 9.9999	1.0000	4	---	
0024	Prescale 7Y	P57.RY	H'FFFFFFF7 to H'00000009: (-9 to 9)	10 -9 to 10 9	10 0	---	---	
0027	Decimal point position 7	dP7	H'00000000 to H'00000004: (0 to 4)	0.0000, 0.000.0, 0.00.00, 0.0.000, 0.0000	0.0000	---	---	

Note The values beginning with H' in the *Monitor/Setting range* column are used when setting or monitoring data via communications.

Comparative Set Value Level

Variable type	Address	Parameter name	Character	Monitor/Setting range	Character	Default setting	Decimal point	Unit
C8	0000	Comparative set value 05	5005	H'FFFFB1E1 to H'0001869F (-19999 to 99999)	19999 to 99999	99999	According to the decimal position setting.	---
	0001	Comparative set value 04	5004	H'FFFFB1E1 to H'0001869F (-19999 to 99999)	19999 to 99999	99999	According to the decimal position setting.	---
	0020	Comparative set value 03	5003	H'FFFFB1E1 to H'0001869F (-19999 to 99999)	19999 to 99999	99999	According to the decimal position setting.	---
	0002	Comparative set value 02	5002	H'FFFFB1E1 to H'0001869F (-19999 to 99999)	19999 to 99999	99999	According to the decimal position setting.	---
	0003	Comparative set value 01	5001	H'FFFFB1E1 to H'0001869F (-19999 to 99999)	19999 to 99999	99999	According to the decimal position setting.	---
	0004	Comparative set value 15	5015	H'FFFFB1E1 to H'0001869F (-19999 to 99999)	19999 to 99999	99999	According to the decimal position setting.	---
	0005	Comparative set value 14	5014	H'FFFFB1E1 to H'0001869F (-19999 to 99999)	19999 to 99999	99999	According to the decimal position setting.	---
	0021	Comparative set value 13	5013	H'FFFFB1E1 to H'0001869F (-19999 to 99999)	19999 to 99999	99999	According to the decimal position setting.	---
	0006	Comparative set value 12	5012	H'FFFFB1E1 to H'0001869F (-19999 to 99999)	19999 to 99999	99999	According to the decimal position setting.	---
	0007	Comparative set value 11	5011	H'FFFFB1E1 to H'0001869F (-19999 to 99999)	19999 to 99999	99999	According to the decimal position setting.	---
	0008	Comparative set value 25	5025	H'FFFFB1E1 to H'0001869F (-19999 to 99999)	19999 to 99999	99999	According to the decimal position setting.	---
	0009	Comparative set value 24	5024	H'FFFFB1E1 to H'0001869F (-19999 to 99999)	19999 to 99999	99999	According to the decimal position setting.	---
	0022	Comparative set value 23	5023	H'FFFFB1E1 to H'0001869F (-19999 to 99999)	19999 to 99999	99999	According to the decimal position setting.	---
	000A	Comparative set value 22	5022	H'FFFFB1E1 to H'0001869F (-19999 to 99999)	19999 to 99999	99999	According to the decimal position setting.	---
	000B	Comparative set value 21	5021	H'FFFFB1E1 to H'0001869F (-19999 to 99999)	19999 to 99999	99999	According to the decimal position setting.	---
	000C	Comparative set value 35	5035	H'FFFFB1E1 to H'0001869F (-19999 to 99999)	19999 to 99999	99999	According to the decimal position setting.	---
	000D	Comparative set value 34	5034	H'FFFFB1E1 to H'0001869F (-19999 to 99999)	19999 to 99999	99999	According to the decimal position setting.	---
	0023	Comparative set value 33	5033	H'FFFFB1E1 to H'0001869F (-19999 to 99999)	19999 to 99999	99999	According to the decimal position setting.	---
	000E	Comparative set value 32	5032	H'FFFFB1E1 to H'0001869F (-19999 to 99999)	19999 to 99999	99999	According to the decimal position setting.	---
	000F	Comparative set value 31	5031	H'FFFFB1E1 to H'0001869F (-19999 to 99999)	19999 to 99999	99999	According to the decimal position setting.	---
	0010	Comparative set value 45	5045	H'FFFFB1E1 to H'0001869F (-19999 to 99999)	19999 to 99999	99999	According to the decimal position setting.	---
	0011	Comparative set value 44	5044	H'FFFFB1E1 to H'0001869F (-19999 to 99999)	19999 to 99999	99999	According to the decimal position setting.	---
	0024	Comparative set value 43	5043	H'FFFFB1E1 to H'0001869F (-19999 to 99999)	19999 to 99999	99999	According to the decimal position setting.	---
	0012	Comparative set value 42	5042	H'FFFFB1E1 to H'0001869F (-19999 to 99999)	19999 to 99999	99999	According to the decimal position setting.	---
	0013	Comparative set value 41	5041	H'FFFFB1E1 to H'0001869F (-19999 to 99999)	19999 to 99999	99999	According to the decimal position setting.	---
	0014	Comparative set value 55	5055	H'FFFFB1E1 to H'0001869F (-19999 to 99999)	19999 to 99999	99999	According to the decimal position setting.	---

Variable type	Address	Parameter name	Character	Monitor/Setting range	Character	Default setting	Decimal point	Unit	
C8	0015	Comparative set value 54	5.5.4	H'FFFFB1E1 to H'0001869F (-19999 to 99999)	19999 to 99999	99999		According to the decimal position setting.	---
	0025	Comparative set value 53	5.5.3	H'FFFFB1E1 to H'0001869F (-19999 to 99999)	19999 to 99999	99999		According to the decimal position setting.	---
	0016	Comparative set value 52	5.5.2	H'FFFFB1E1 to H'0001869F (-19999 to 99999)	19999 to 99999	99999		According to the decimal position setting.	---
	0017	Comparative set value 51	5.5.1	H'FFFFB1E1 to H'0001869F (-19999 to 99999)	19999 to 99999	99999		According to the decimal position setting.	---
	0018	Comparative set value 65	5.5.5	H'FFFFB1E1 to H'0001869F (-19999 to 99999)	19999 to 99999	99999		According to the decimal position setting.	---
	0019	Comparative set value 64	5.5.4	H'FFFFB1E1 to H'0001869F (-19999 to 99999)	19999 to 99999	99999		According to the decimal position setting.	---
	0026	Comparative set value 63	5.5.3	H'FFFFB1E1 to H'0001869F (-19999 to 99999)	19999 to 99999	99999		According to the decimal position setting.	---
	001A	Comparative set value 62	5.5.2	H'FFFFB1E1 to H'0001869F (-19999 to 99999)	19999 to 99999	99999		According to the decimal position setting.	---
	001B	Comparative set value 61	5.5.1	H'FFFFB1E1 to H'0001869F (-19999 to 99999)	19999 to 99999	99999		According to the decimal position setting.	---
	001C	Comparative set value 75	5.7.5	H'FFFFB1E1 to H'0001869F (-19999 to 99999)	19999 to 99999	99999		According to the decimal position setting.	---
	001D	Comparative set value 74	5.7.4	H'FFFFB1E1 to H'0001869F (-19999 to 99999)	19999 to 99999	99999		According to the decimal position setting.	---
	0027	Comparative set value 73	5.7.3	H'FFFFB1E1 to H'0001869F (-19999 to 99999)	19999 to 99999	99999		According to the decimal position setting.	---
	001E	Comparative set value 72	5.7.2	H'FFFFB1E1 to H'0001869F (-19999 to 99999)	19999 to 99999	99999		According to the decimal position setting.	---
	001F	Comparative set value 71	5.7.1	H'FFFFB1E1 to H'0001869F (-19999 to 99999)	19999 to 99999	99999		According to the decimal position setting.	---

Note The values beginning with H' in the *Monitor/Setting range* column are used when setting or monitoring data via communications.

Linear Output Level

Variable type	Address	Parameter name	Character	Monitor/Setting range	Character	Default setting	Decimal point	Unit
C9	0000	Linear current type	1.5E.L	H'00000000: 0-20 mA (0), H'00000001: 4-20 mA (1)	0-20, 4-20	4-20	---	---
	0001	Linear voltage type	1.5E.V	H'00000000: 0-5 V (0), H'00000001: 1-5 V (1), H'00000002: 0-10 V (2)	0-5, 1-5, 0-10	1-5	---	---
	0002	Linear output upper limit	1.5E.H	H'FFFFB1E1 to H'0001869F (-19999 to 99999)	19999 to 99999	99999		---
	0003	Linear output lower limit	1.5E.L	H'FFFFB1E1 to H'0001869F (-19999 to 99999)	19999 to 99999	19999		---

Note The values beginning with H' in the *Monitor/Setting range* column are used when setting or monitoring data via communications.

Communications Setting Level

Variable type	Address	Parameter name	Character	Monitor/Setting range	Character	Default setting	Decimal point	Unit
CA	0000	Communications unit number	ሀ-ገፅ	H'00000000 to H'00000063: (0 to 99)	0 to 99	1	---	---
	0001	Baud rate	ቅፆ	H'00000000: 9.6 (0), H'00000001: 19.2 (1), H'00000002: 38.4 (2)	9.6, 19.2, 38.4	9.6	---	kbps
	0002	Communications data length	፲፭ገ	H'00000000: 7 (0), H'00000001: 8 (1)	7, 8	7	---	bit
	0003	Communications stop bits	፩፡፪	H'00000000: 1 (0), H'00000001: 2 (1)	1, 2	2	---	bit
	0004	Communications parity	የገፅ	H'00000000: None (0), H'00000001: Even (1), H'00000002: Odd (2)	ገፅ, የሀፀገ, ፅፅፅ	የሀፀገ	---	---
	0005	Send wait time	፩፡፪	H'00000000 to H'00000063: (0 to 99)	0 to 99	20	---	ms

Note The values beginning with H' in the *Monitor/Setting range* column are used when setting or monitoring data via communications.

Advanced Function Setting Level

Variable type	Address	Parameter name	Character	Monitor/Setting range	Character	Default setting	Decimal point	Unit
CB	0002	Output OFF delay	ፅፆፍ	H'00000000 to H'000007CF: (0 to 1999)	0 to 1999	0	---	ms
	0003	Shot output	፩፡፪	H'00000000 to H'000007CF: (0 to 1999)	0 to 1999	0	---	ms
	0004	Output logic	ፅፅፅ-ገ	H'00000000: Close in alarm (0), H'00000001: Open in alarm (1)	ገ-ፅ, ገ-፭	ገ-ፅ	---	---
	0009	Bank selection	ቅፆ-፭	H'00000000: OFF (0), H'00000001: KEY (1), H'00000002: EV (2)	ፅፆፍ, የፀፀ, የሀ	ፅፆፍ (See note 2.)	---	---

Note (1) The values beginning with H' in the *Monitor/Setting range* column are used when setting or monitoring data via communications.
 (2) If the event connector is provided as a standard feature or an event connector is added, use EV for the "bank selection" setting.

Part 2: DeviceNet

SECTION 1 Overview	3-1
1-1 Features	3-2
1-2 Specifications	3-5
SECTION 2 Operating Procedures	4-1
2-1 Introduction	4-2
2-2 Functions Supported Only by the K3HB-DRT	4-4
SECTION 3 Parts, Installation, and Wiring	5-1
3-1 Part Names and Functions	5-2
3-2 DeviceNet Communications Cables Wiring	5-4
SECTION 4 Remote I/O Communications	6-1
4-1 Overview	6-2
4-2 I/O Allocation	6-2
4-3 Ladder Programming Examples	6-7
SECTION 5 Explicit Message Communications	7-1
5-1 Overview of Explicit Message Communications	7-2
5-2 Sending CompoWay/F Commands to the Digital Indicator	7-4
5-3 Explicit Messages Specific to DeviceNet-compatible Digital Indicators	7-6
SECTION 6 Communications Performance	8-1
6-1 Remote I/O Communications Performance	8-2
6-2 Message Communications Performance	8-6
SECTION 7 Troubleshooting and Maintenance	9-1
7-1 Indicators and Error Processing	9-2
7-2 Maintenance	9-3
SECTION 8 Additional Information for DeviceNet ...	10-1
8-1 Detailed DeviceNet Specifications	10-2
8-2 Mounted Objects	10-3
8-3 DeviceNet Connection Hardware	10-7
8-4 Glossary	10-10

SECTION 1

Overview

This section introduces the features and specifications of K3HB-DRT Digital Indicators.

1-1	Features	3-2
1-1-1	Outline	3-2
1-1-2	Communications Connection Example	3-2
1-1-3	Using DeviceNet	3-3
1-1-4	Default Communications Settings	3-3
1-1-5	Data Allocation	3-3
1-1-6	Remote I/O Communications	3-4
1-2	Specifications	3-5
1-2-1	DeviceNet Communications Specifications	3-5
1-2-2	DeviceNet General Specifications	3-6

1-1 Features

In this manual, the DeviceNet-compatible K3HB Digital Indicator is abbreviated as K3HB-DRT.

1-1-1 Outline

The K3HB-DRT Digital Indicators are slaves that connect to the DeviceNet open field network. DeviceNet communications enable controlling operation, collecting measurement data, and writing settings from a host computer or PLC. The K3HB-DRT support both remote I/O communications and explicit message communications.

Remote I/O communications allow the master and the K3HB-DRT to automatically share data via high-speed I/O without any special programming of the master. Remote I/O communications are particularly suited to operation control, error warnings, and monitoring applications.

Explicit messages use a communications protocol for sending commands and receiving responses. The main application for explicit message communications is for changing K3HB-DRT settings data.

1-1-2 Communications Connection Example

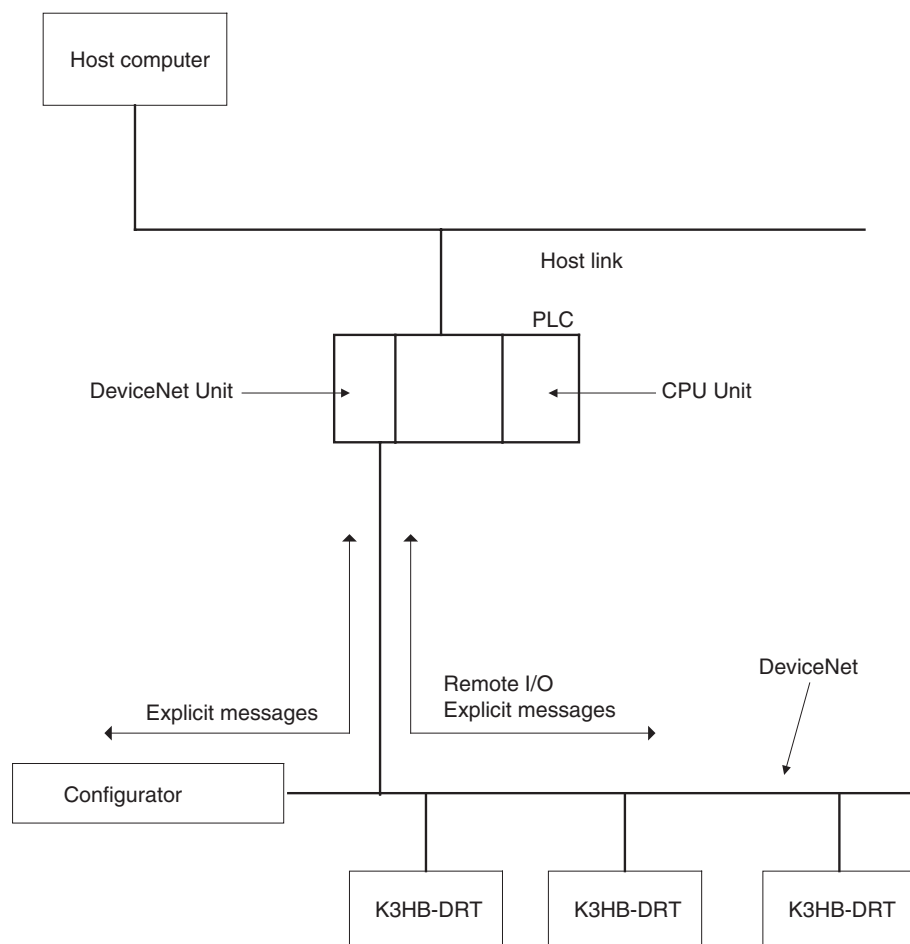

1-1-3 Using DeviceNet

Remote I/O Communications

The master and K3HB-DRT Digital Indicators can share I/O by using remote I/O communications. Data in the K3HB-DRT Digital Indicators, such as measurement values and comparative set values, can be allocated for communications with the master to enable sending and receiving the allocated data via remote I/O communications without requiring special programming.

- User-set Data Allocations with a Configurator

The specific data required for communications with the master can be allocated by using I/O allocations from the DeviceNet Configurator.

Explicit Message Communications

By sending commands from a PLC, various operations can be performed, including reading/writing specific monitor values and parameters, such as reading measurement values or writing comparative set values, and performing operations using operation commands. CompoWay/F communications commands can also be executed using explicit message communications.

Automatically Detects Baud Rate

Previously, the baud rate had to be set for each slave, but the K3HB-DRT Digital Indicators automatically detect and match the baud rate of the master, so this setting is not required. (If the master's baud rate is changed, turn OFF the communications power supply to the Digital Indicator and then turn it ON again.)

1-1-4 Default Communications Settings

The default settings required for communications when K3HB-DRT are used as DeviceNet slaves are listed in the following diagram.

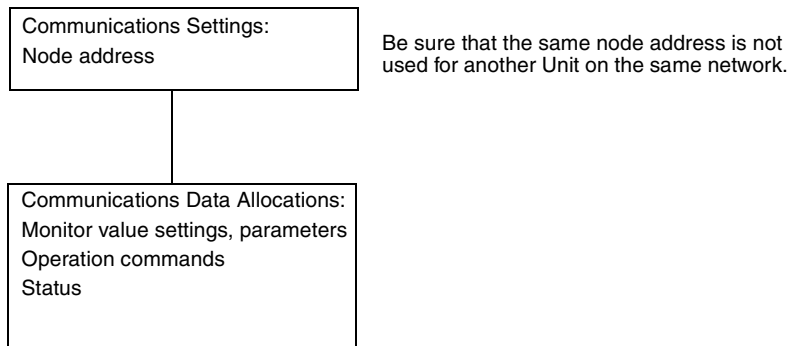

Refer to the *DeviceNet Operation Manual* (Cat. No. W267) for information such as the order for turning ON power to the master and slaves and master I/O tables.

1-1-5 Data Allocation

K3HB-DRT communications data must be allocated for the Read and Write Areas for communications with the master. Up to 30 items can be allocated for the Read Area and up to 15 items can be allocated for the Write Area. The data for each word is allocated using the parameters write data 1 to 15 and read data 1 to 15.

Unused words can be specified to reserve space according to data types or to otherwise reduce the number of words.

Refer to 4-2 I/O Allocation on page 6-2 for details on allocation methods.

1-1-6 Remote I/O Communications

Read/write table data is automatically read and written when communications start. The Communications Write setting must be set to ON to write data from the master to the K3HB-DRT. Data will not be written to the Digital Indicator if the Communications Write setting is OFF. The following diagram shows communications with the default data allocation parameters.

Note The Communications Write setting is ON by default.

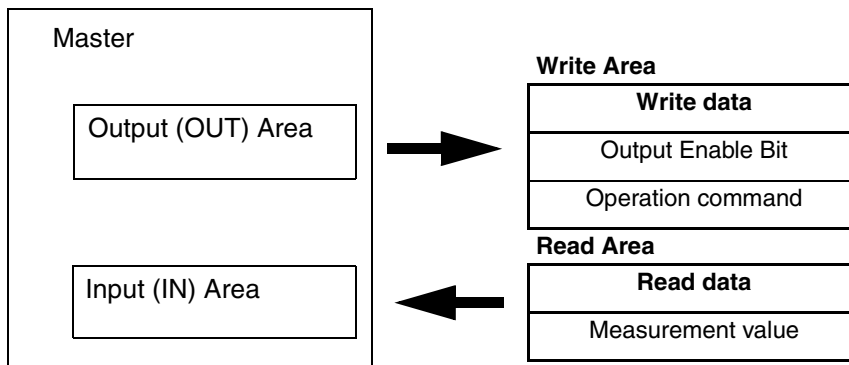

1-2 Specifications

1-2-1 DeviceNet Communications Specifications

Item		Specifications			
Communications protocol		Conforms to DeviceNet			
Communications functions	Remote I/O communications	<ul style="list-style-type: none"> • Master-slave connections (polling, bit-strobe, COS, or cyclic) • Conform to DeviceNet specifications. 			
	I/O allocations	<ul style="list-style-type: none"> • Can allocate any I/O data from the Configurator. • Can allocate any data, such parameters specific to the DeviceNet and the Digital Indicator variable area. • Up to 2 blocks for the IN Area, up to a total of 60 words (See note 1.) • One block for the OUT Area, up to 29 words (The first word is always allocated to Output Enable Bits.) (See note 2.) 			
	Message communications	<ul style="list-style-type: none"> • Explicit message communications • CompoWay/F communications commands can be sent (commands are sent in explicit message format). 			
Connection format		Combination of multidrop and T-branch connections (for trunk and drop lines)			
Baud rate		DeviceNet: 500, 250, or 125 kbps, or automatic detection of master baud rate			
Communications media		Special 5-wire cable (2 signal lines, 2 power lines, and 1 shield line)			
Communications distance	Baud rate	Network length	Drop line length	Total drop line length	
	500 kbps	100 m max. (100 m max.)	6 m max.	39 m max.	
	250 kbps	100 m max. (250 m max.)	6 m max.	78 m max.	
	125 kbps	100 m max. (500 m max.)	6 m max.	156 m max.	
	The values in parentheses apply when Thick Cables are used.				
Communications power supply		11 to 25 VDC			
Maximum number of nodes that can be connected		64 (includes Configurator when used)			
Maximum number of slaves that can be connected		63			
Error control		CRC error detection			
Power supply		Power supplied from DeviceNet communications connector			

- Note**
- (1) The IN Area can be divided into two blocks only when a CS/CJ-series DeviceNet Unit is used as the master. (The connection type can also be selected.) If a CVM1, CV, or C200HX/HG/HE DeviceNet Master Unit is used as the master, the IN Area must be in 1 block with a maximum 100 words (200 bytes). (Polling connection only.)
 - (2) If a CVM1, CV, or C200HX/HG/HE DeviceNet Master Unit used, only up to 32 words can be allocated per node.

1-2-2 DeviceNet General Specifications

Item	Specifications
Supply voltage	DeviceNet power supply: 24 VDC (internal circuit)
Allowable voltage range	DeviceNet power supply: 11 to 25 VDC
Current consumption	DeviceNet power supply: 50 mA max. (24 VDC)
Vibration resistance	Vibration: 10 to 55 Hz Acceleration: 50 m/s ²
Shock resistance	150 m/s ² max. 3 times each in 3 axes, 6 directions
Dielectric strength	2,300 VAC for 1 min. between all the external terminals and case
Insulation resistance	20 MΩ min. (at 500 VDC)
Ambient temperature	−10 to 55°C (with no condensation or icing)
Ambient humidity	25% to 85%
Storage temperature	−25 to 65°C (with no condensation or icing)
Enclosure rating	IP00 (connector)
Memory protection	EEPROM (100,000 write operations)
Weight	DeviceNet connector: Approx. 8 g Crimp terminals: Approx 1 g (each)

SECTION 2

Operating Procedures

This section outlines the basic operating procedures for the K3HB-DRT Digital Indicators.

- 2-1 Introduction 4-2
 - 2-1-1 Setup Procedure 4-2
 - 2-1-2 Startup Procedure 4-2
 - 2-1-3 Setting Node Addresses 4-3
- 2-2 Functions Supported Only by the K3HB-DRT 4-4
 - 2-2-1 Network Power Monitor Function 4-4
 - 2-2-2 Unit Conduction Time Monitor Function 4-4

2-1 Introduction

Use the procedures in the following sections to prepare the K3HB-DRT Digital Indicators for use. Refer to the following reference pages/sections provided for detailed information on each step.

2-1-1 Setup Procedure

Step	Item	Details	Reference
1	Mount the Digital Indicator.	Mount the Digital Indicator to the panel.	page 5-2
2	Wire the Digital Indicator.	Wire the temperature inputs and comparative outputs to the Digital Indicator terminals. Note Do not turn ON the power supply to the peripheral devices at this time.	---
3	Turn ON the power to the Digital Indicator.	Turn ON the power connected to the Digital Indicator. Note The Digital Indicator will start.	---
4	Set the DeviceNet node address.	Set the DeviceNet node address (0 to 63) for the Digital Indicator on the front panel. Set a unique node address for each slave connected to the same master.	page 4-3
5	Turn OFF the power to the Digital Indicator.	Turn OFF the power connected to the Digital Indicator.	---

2-1-2 Startup Procedure

Prepare the master, DeviceNet communications power supply, and Configurator that will be used in the system. Use the Configurator to allocate Digital Indicator data in the IN and OUT Areas. Refer to the *DeviceNet Operation Manual (W267)* for information on related connection devices.

Note Up to 30 items can be allocated in the IN Area and up to 15 items can be allocated in the OUT Area for remote I/O communications. To read and write larger amounts of data, use explicit messages. Use explicit messages also for reading and writing data only when required.

Step	Item	Details	Reference
6	Connect the DeviceNet communications connector.	Connect the DeviceNet communications connector. Note Do not turn ON the communications power supply at this time. This power supply is also used as the internal circuit power supply for DeviceNet communications.	page 5-4
7	Turn ON the power to the Digital Indicator.	Turn ON the power connected to the Digital Indicator. Note The Digital Indicator will start.	---
8	Turn ON the DeviceNet communications power (V+, V-).	Turn ON the communications power supply to DeviceNet. Note The DeviceNet communications will start.	---
9	Check the MS/NS indicators	Check that the status of the MS and NS indicators is as follows: MS: Operating normally when lit green. NS: Operating normally when lit green. (DeviceNet online or communications connected.)	page 5-3

Step	Item	Details	Reference
10	Operate from the Configurator.	Set from the Configurator when changing data allocated in the IN and OUT Areas from the default values. To split the IN Area used by the K3HB-DRT into two areas, select K3HB-DRT in the master's Edit Device Parameters Window and set the connection in the detailed settings. When the IN Area is split into two areas, for example, operating parameters, such as measurement values and comparative set values, can be allocated in IN Area 1, and status values can be allocated in IN Area 2. For example, IN Area 1 can be allocated in the DM Area and IN Area 2 can be allocated in the CIO Area.	SECTION 4 Remote I/O Communications
11	Start remote I/O communications.	Enable the master's scan list and change the PLC to RUN Mode. Remote I/O communications will start, and the contents of the IN and OUT Areas in the master and K3HB-DRT Digital Indicator will be synchronized.	---
12	Use explicit message communications.	Send explicit messages from the master. Explicit messages can be used to perform control and monitoring that cannot be achieved using the IN and OUT Areas alone, by sending explicit messages to the K3HB-DRT Digital Indicator.	SECTION 5 Explicit Message Communications

- Note**
- (1) When changing the baud rate of the master after starting the K3HB-DRT Digital Indicator, turn ON the communications power supply of the Digital Indicator again, and restart the Digital Indicator.
When setting the Configurator only, without a master, the baud rate of the Configurator will be automatically detected.
 - (2) The following points are important when editing device parameters using the Configurator.
 - It is recommended that device default values are uploaded before the parameters are edited because the EDS parameter defaults and the device defaults are different.
 - The setting for some parameters are different for the list of settings provided in the *CompoWay/F SECTION 2 List of Settings*. For example, the parameter setting for input type A is different for each model.
 - Set the unit number in the Communications Setting Level parameter group to change the node address.

2-1-3 Setting Node Addresses

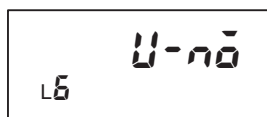

(U-NO)

DeviceNet node addresses are set in the communications setting level. Set the node addresses on the front panel of the K3HB-DRT.

Parameter	Setting value	Meaning
Unit No. U-NO	0 to 99	0 to 99 (See note.)

Note The node address will be 0 if an address between 64 and 99 is set.

Setting Parameters



A. Press the LEVEL Key for at least 3 s to move to the input initial setting level.

- The initial setting level is indicated by L6 being displayed in the level/bank display.

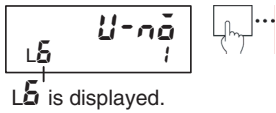

B. Press the LEVEL Key several times to move to the communications setting level.

- The communications setting level is indicated by L5 being displayed in the level/bank display.

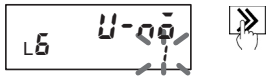

C. Press the SHIFT Key so that the SV display flashes.

- The SV will flash to indicate that it can be changed.

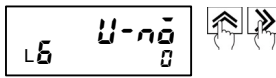

D. Press the UP and SHIFT Keys to change the Unit No. (DeviceNet node address) setting.

The number of words allocated will depend on the K3HB-DRT communications data allocations. The following points are important when setting node addresses or allocating I/O memory.

- Do not allocate the same words to other slaves.
- Make sure the I/O area does not exceed the valid range.

2-2 Functions Supported Only by the K3HB-DRT

A Configurator is used to make settings for the network power monitor function and Unit conduction time monitor function.

2-2-1 Network Power Monitor Function

The K3HB-DRT has a network power monitor function that turns ON the Communications Power Voltage Monitor Error Flag in the General Status when the communications power voltage drops below the set monitor value. The monitor value for the network power voltage is set using the Configurator and is found in the General Setting parameter group.

2-2-2 Unit Conduction Time Monitor Function

The K3HB-DRT has a Unit conduction time monitor function that records internally the total time communications power is supplied to the Digital Indicator. The Unit Maintenance Flag in the General Status will turn ON if the Unit conduction time exceeds a set monitor value.

The Detection Time (Unit conduction time monitor value) is set using a Configurator and is found in the General Setting parameter group.

The Unit conduction time monitor can be used as a guide for replacing the K3HB-DRT Digital Indicator.

Measurement unit: 0.1 h

Measurement range: 0 to 429496729.5 h (Stored data: 00000000 to FFFFFFFF hex).

Note

- (1) The conduction time is held even when the power is turned OFF.
- (2) The conduction time will not be measured if communications power is not supplied to the K3HB-DRT.
- (3) The K3HB-DRT Digital Indicator checks the ON status of the target channel approximately every 0.1 h (6 min).

SECTION 3

Parts, Installation, and Wiring

This section describes the methods used to install and wire K3HB-DRT Digital Indicators.

3-1	Part Names and Functions.	5-2
3-1-1	Part Names	5-2
3-1-2	External Dimensions.	5-2
3-1-3	MS and NS Indicators.	5-3
3-2	DeviceNet Communications Cables Wiring	5-4
3-2-1	Preparing DeviceNet Communications Cables	5-4
3-2-2	Attaching the DeviceNet Communications Unit Connector	5-6

3-1 Part Names and Functions

3-1-1 Part Names

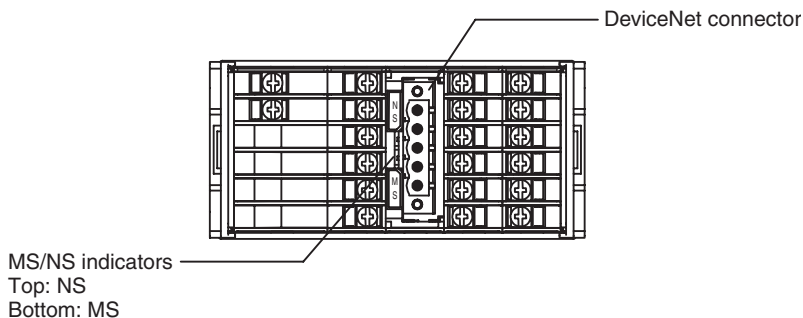

DeviceNet Communications Connector

The DeviceNet communications connector is used to connect the communications cable to the DeviceNet network. The DeviceNet communications power is also supplied through this connector. The connector provided with the Digital Indicator is a HR31-5.08P-5SC(01) (Hirose Electric). The provided connector crimp terminals are HR31-SC-121 (Hirose Electric) and are for Thin DeviceNet Communications Cables. The K3HB-DRT cannot be used with any other connector than the DeviceNet one provided.



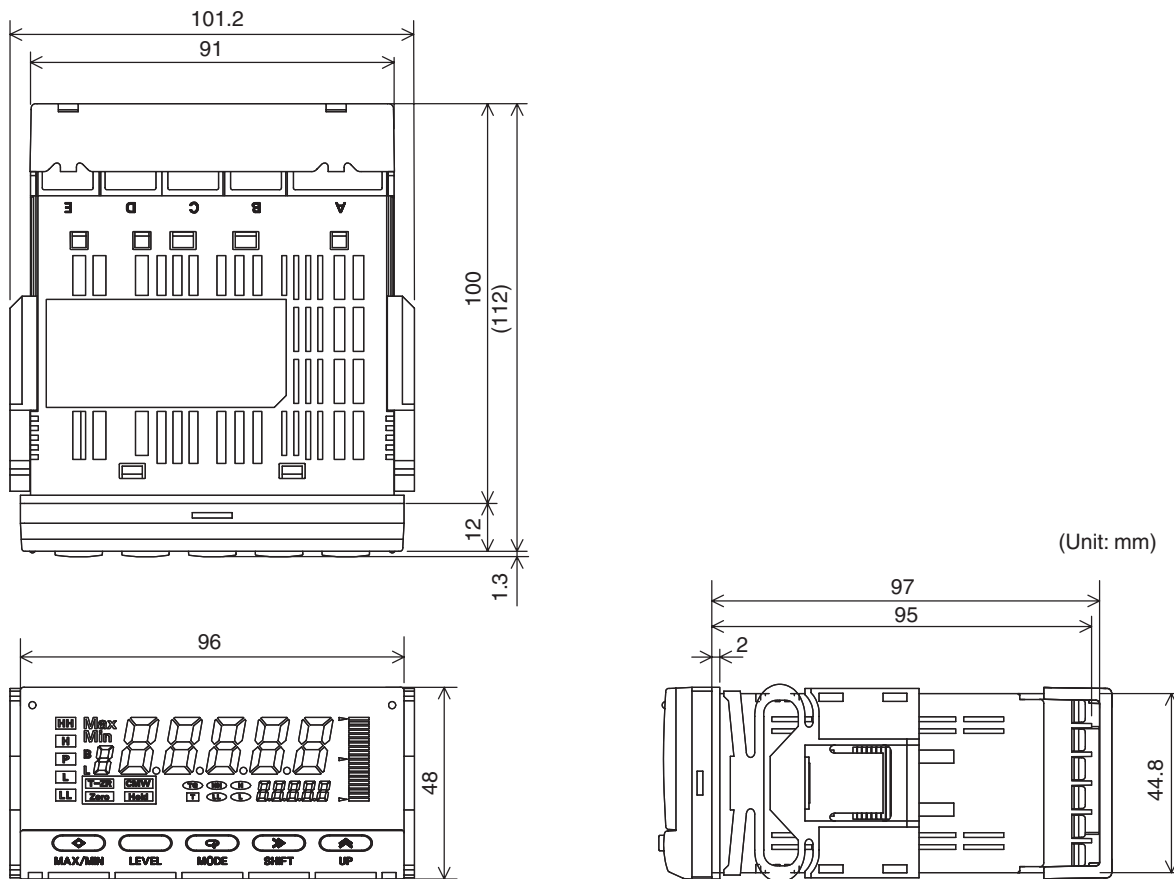





3-1-2 External Dimensions



Parts, Installation, and Wiring

3-1-3 MS and NS Indicators

The indicators show the status of the Digital Indicator and the DeviceNet Network.

Indicator	Name	Color	Status	Meaning (main errors)
MS	Module status	Green		The Digital Indicator is normal.
		Red		Fatal error <ul style="list-style-type: none"> Digital Indicator error Watchdog timer error (DeviceNet communications)
				Non-fatal error <ul style="list-style-type: none"> Unit error Unit changed Display Unit error Non-volatile memory error.
		OFF		No power is being supplied. <ul style="list-style-type: none"> DeviceNet communications power is not being supplied. Power is not being supplied to the Digital Indicator. The Digital Indicator is being reset. Waiting for initialization to start.
NS	Network status	Green		Online/communications established (normal network status)
				Online/communications established (waiting for communications to be established with the master)
		Red		Fatal communications error (The Digital Indicator has detected an error that does not allow communications with the network.) <ul style="list-style-type: none"> Node address duplication error Bus Off error detected
				Non-fatal communications error <ul style="list-style-type: none"> Communications timeout
		OFF		Offline or power supply is OFF <ul style="list-style-type: none"> Waiting for completion of the master's node address duplication check. DeviceNet communications power is not being supplied.



Normal Indicator Display

The MS and NS indicators are both lit green when the status of the Digital Indicator and the Network are normal.

Parts, Installation, and Wiring

3-2 DeviceNet Communications Cables Wiring

The methods used for preparing DeviceNet communications cables to be connected for DeviceNet communications are explained here.

For details on the DeviceNet Network, such as supplying the DeviceNet communications power and grounding the DeviceNet Network, refer to the *DeviceNet Operation Manual (W267)*.

3-2-1 Preparing DeviceNet Communications Cables

Use the following procedure to prepare and connect the communications cables to the connectors.

- 1,2,3...**
1. Remove approximately 30 to 80 mm of the cable covering, being careful not to damage the shield mesh underneath. Do not remove too much covering or a short circuit may result.

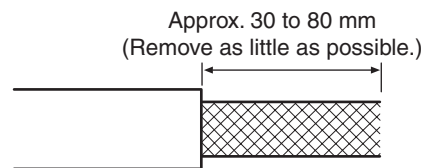

2. Carefully peel back the shield mesh to reveal the signal lines, power lines, and the shield wire. The shield wire is slightly harder to the touch than the mesh.

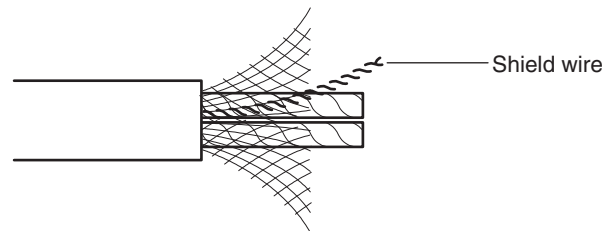

3. Remove the exposed mesh and the aluminum tape from the signal and power lines. Strip the covering from the signal and power lines to the proper length for the crimp terminals. Twist together the wires of each of the signal and power lines.

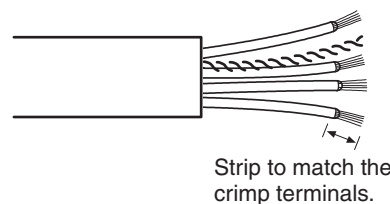

4. Attach crimp terminals to the lines and then cover any exposed areas with vinyl tape or heat-shrink tubing. Making sure that the connector hole numbers are correct, insert each of the signal lines, power supply lines, and the shield wire into the corre-

spending connector holes, as shown in the following diagram.

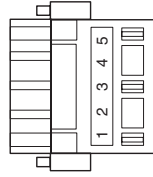

- 1: V- (Power line: black)
- 2: CAN low (Communications line: blue)
- 3: Shield
- 4: CAN high (Communications line: white)
- 5: V+ (Power line: red)

Make sure that the connector is oriented correctly before inserting the crimp terminal into the connector, as shown in the following diagram.

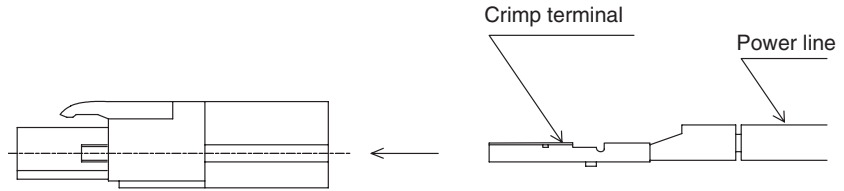

The crimp terminals can be crimped using a crimp tool that conforms to JIS C9711. The following crimp tool is also available: HR31-TC-01 (Hirose Electric)

If wiring is not correct, use an extraction tool to extract the wires using the following procedure.

1,2,3...

1. Press down the molded transformer using the extraction tool, as shown in Fig. 1.
2. While keeping the molded transformer pressed down, tilt the extraction tool to release the crimp terminal lock.
3. Remove the extraction tool.
4. Pull the cable and pull out the crimp terminal.

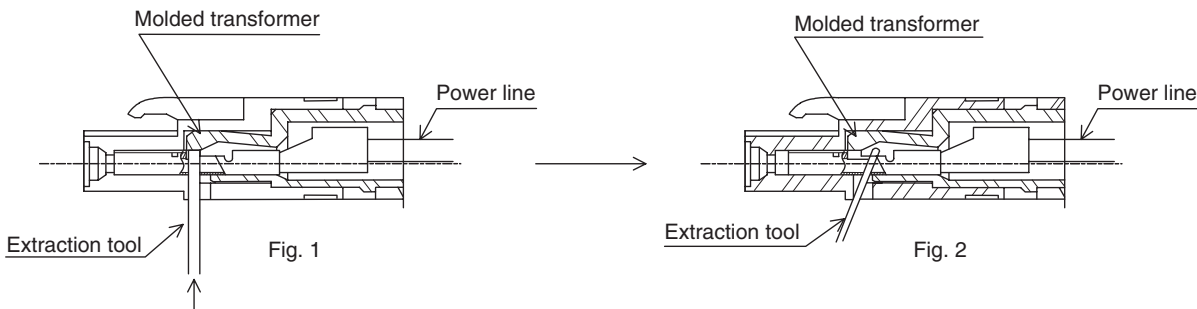

The following extraction tool is available: HR31-SC-TP (Hirose Electric)

Parts, Installation, and Wiring

3-2-2 Attaching the DeviceNet Communications Unit Connector

Align the DeviceNet Communications Unit connector (marked with a C) with the cable connector, and insert the cable connector fully into the DeviceNet Communications Unit connector.

Tighten the set screws to a torque between 0.18 and 0.22 N·m to secure the connector.

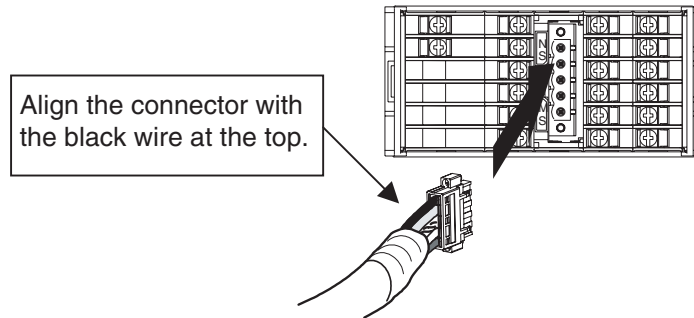

Use the following crimp terminals if using Thick DeviceNet Communications Cables.

HR31-SC-111 (Hirose Electric)

SECTION 4

Remote I/O Communications

This section describes the input (IN) areas and output (OUT) areas that K3HB-DRT Digital Indicators can use for remote I/O communications. The methods to allocate data for master communications are also described using sample programming.

4-1	Overview	6-2
4-2	I/O Allocation	6-2
4-2-1	Allocation Area Sizes (IN Data Size and OUT Data Size)	6-3
4-2-2	Allocation Parameters	6-3
4-2-3	Allocation Default Values	6-4
4-2-4	Allocation Settings	6-4
4-2-5	Input Data	6-5
4-2-6	Output Data	6-5
4-2-7	Operation Commands	6-6
4-3	Ladder Programming Examples	6-7
4-3-1	Zero Execute/Cancel Sample Programming	6-7

4-1 Overview

I/O memory in the master can be allocated to data from the K3HB-DRT Digital Indicator, such as data from the Digital Indicator's variable area, merely by specifying what Digital Indicator data is to be transferred to where.

Data is automatically exchanged between the master and Digital Indicator, allowing the Digital Indicator to be controlled and monitored from the master without requiring special communications programming.

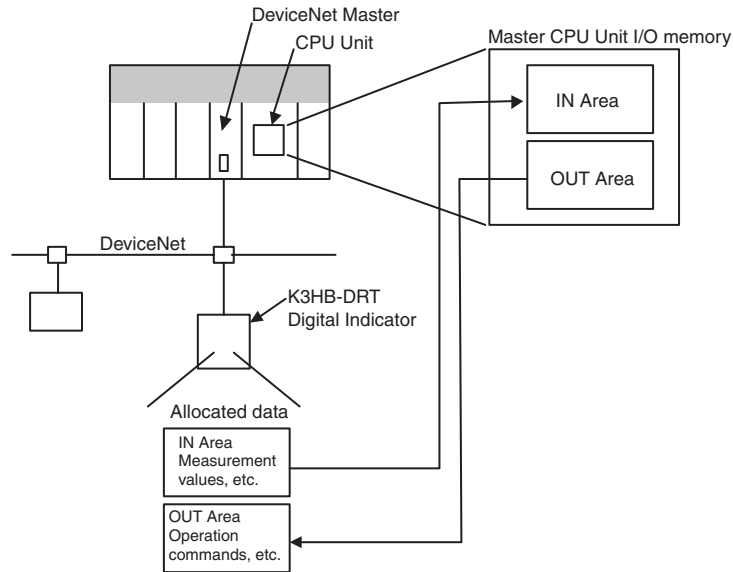

4-2 I/O Allocation

The Configurator can be used to select any data from the list of allocation parameters for the Digital Indicator and then allocate the data in a user-set destination.

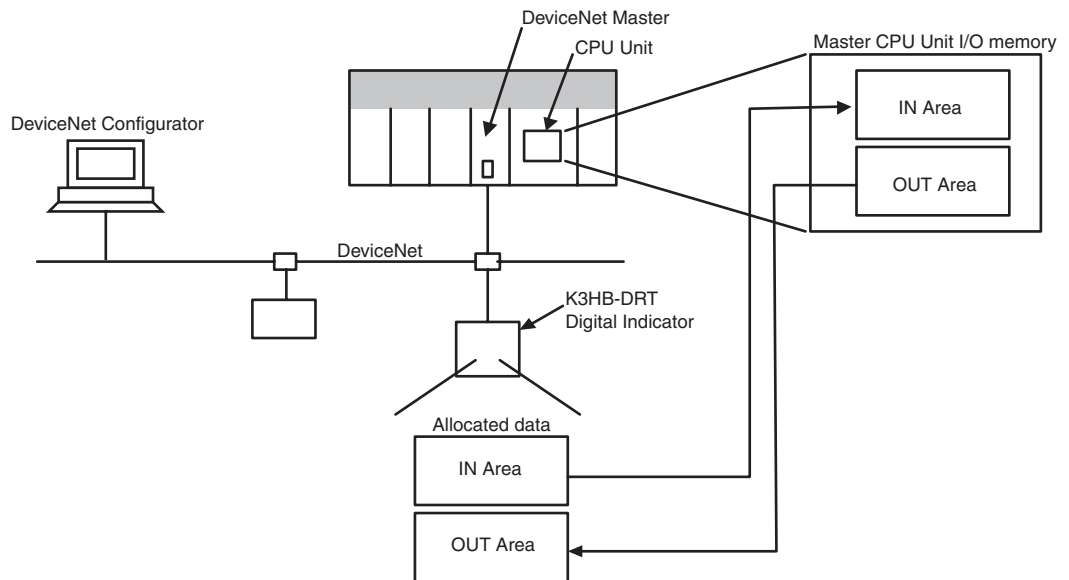

4-2-1 Allocation Area Sizes (IN Data Size and OUT Data Size)

The size of allocated data in each of the IN and OUT Areas is shown in the following table.

I/O memory	Words	Bytes	Setting	
			Allocated data size: 2 bytes	Allocated data size: 4 bytes
IN Area	0 to 60	0 to 120	30	30
OUT Area	0 to 29	0 to 58	15	15

- Note**
- (1) When the master is a CS/CJ-series DeviceNet Unit, the IN Area can be divided into two areas (IN Area 1 and IN Area 2). Any allocation data from the list of parameters can be allocated in each area.
 - (2) The actual size of the allocated area depends on the size of allocation data selected.
 - (3) The default allocation data size is two bytes.

When the allocation data size is two bytes, the monitor and setting data will be displayed in the range FFFF hex to 0000 hex. Data will be fixed at 7FFF hex or 8000 hex if the data exceeds the range that can be displayed. For example, -32769 would be displayed as 8000 hex.

The following data sizes are fixed, however.

- General status: 2 bytes (fixed)
- K3HB-DRT status: 4 bytes (fixed)
- K3HB-DRT Output Enable Bits and operation commands: 2 bytes (fixed)

- Note** Refer to *4-2-5 Input Data* on page 6-5 for details on General Status. Refer to *4-2-6 Output Data* on page 6-5 for details on Output Enable Bits and operation commands.

4-2-2 Allocation Parameters

The parameters that can be allocated are shown below. These parameters can be broadly classified as K3HB-DRT status bits/operation commands, and K3HB-DRT operation data and setting data.

1. K3HB-DRT Status Bits/Operation Commands

The status bits and operation commands for the K3HB-DRT Digital Indicator are shown in the following table.

For status details, refer to the *CompoWay/F SECTION 2 List of Settings*.

Read	Write	Item
Yes	No	General status
No	Yes	Operation commands

- Note**
- (1) When items that are write-only are allocated in the IN Area, they are always set to 0.
 - (2) When items that are read-only are allocated in the OUT Area, they are allocated words in memory but operate the same as if they had not been allocated.

2. K3HB-DRT Operation Data and Setting Data

Monitor values and setting data with communications addresses that belong to the following variable types can be allocated. Duplicate settings are possible and are processed in ascending order.

Variable type	
C0	Operation monitor data
C2	RUN level

Note If items are allocated in the read-only area of the OUT Area, words are allocated in memory but operate as if they had not been allocated.

3. Output Enable Bits

Output Enable Bits are allocated in the first word of the OUT Area.

When Output Enable Bits are allocated in the IN Area, they are always set to 0 (OFF).

Note If data allocated to the IN or OUT Area is changed, use a software reset or cycle the power to enable the new settings.

4-2-3 Allocation Default Values

The default values for I/O allocations are listed in the following table.

Area	Item
IN Area	Measurement value
OUT Area	Output Enable Bits
	Operation commands

4-2-4 Allocation Settings

The I/O allocation settings are listed in the following table.

Allocated to IN Area	Allocated to OUT Area	Configurator display	Setting data name	Allocation data size
No	Yes	-1	OUT Enabled Bits	2 bytes, fixed
No	Yes	Operation command	Operation command	Default value: 2 bytes
No	No	Generic status	Generic status	Default value: 2 bytes
Yes	No	Status	Status	4 bytes, fixed
Yes	No	Measurement value	Measurement value	Default value: 2 bytes
Yes	No	Maximum value	MAX value	Default value: 2 bytes
Yes	No	Minimum value	MIN value	Default value: 2 bytes
Yes	Yes	Comparative set value HH (OUT5)	Comparative set value HH (OUT5)	Default value: 2 bytes
Yes	Yes	Comparative set value H (OUT4)	Comparative set value H (OUT4)	Default value: 2 bytes
Yes	Yes	Comparative set value L (OUT2)	Comparative set value L (OUT2)	Default value: 2 bytes
Yes	Yes	Comparative set value LL (OUT1)	Comparative set value LL (OUT1)	Default value: 2 bytes
Yes	Yes	Comparative set value PASS (OUT3)	Comparative set value PASS (OUT3)	Default value: 2 bytes

4-2-5 Input Data

The input data specific to Digital Indicators with DeviceNet communications that is not allocated in the variable area of the K3HB-DRT is described here.

General Status

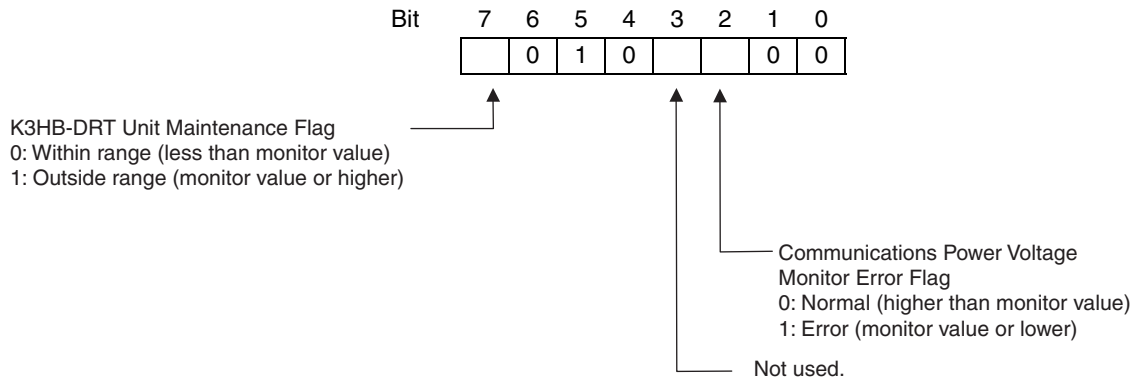

- The Communications Power Voltage Monitor Error Flag indicates the status of the power being supplied through the DeviceNet communications cable.
- The Unit Maintenance Flag is set to 1 when the Unit conduction time of the K3HB-DRT Digital Indicator exceeds the monitor value.

4-2-6 Output Data

Output data specific to DeviceNet that is not allocated to the K3HB-DRT variable area is described here.

Output Enable Bits

Output Enable Bits are used when settings are written to the OUT Area, e.g., when comparative set values are set or RUN/STOP is executed using operation commands. The area for Output Enable Bits is always allocated in the first word of the OUT Area.

When Output Enable Bits are set to 0 (OFF), the settings and bits set in the OUT Area are not transmitted and, therefore, nothing is executed. The settings can be executed by setting the Output Enable Bits to 1 (ON). Writing is not executed if the Output Enable Bits are not set to 1.

Setting Output Enable Bits prevents unintentional setting changes and enables various settings in the OUT Area to be enabled simultaneously. For example, a new value may be written to a word for which a SP has already been set. If the Output Enable Bits are set to 1 and then set to 0, no SP will be written even if one is accidentally allocated. (However, care must be taken because writing is enabled if Output Enable Bits are set to 1.)

Furthermore, if set values are written for all the words and the Output Enable Bits are set to 1, the set values will all be enabled at once.

Note When Output Enable Bits are set to 1, data allocated to the OUT Area is written whenever it changes.

4-2-7 Operation Commands

Operation commands are used for software resetting, to move to setting area 1, and other similar operations. As shown in the following table, operation commands are executed using a combination of command codes, related information, and strobes.

Operation commands for the K3HB-DRT are shown in the following table.

Command code	Details	Related information
00	Communications write	00: OFF (Read only) 01: ON (Read/write)
01	Reset	00
02	Bank selection	00 to 07: Bank 0 to bank 7
03	Zero execute/cancel	00: Zero cancel 01: Zero execute
06	Software reset	00
07	Move to Setting Area 1	00
08	Move to protect level	00
0B	Initialize setting	00

Note A software reset will not respond (no service PDU response).

Operation commands are created as shown in the following diagram.

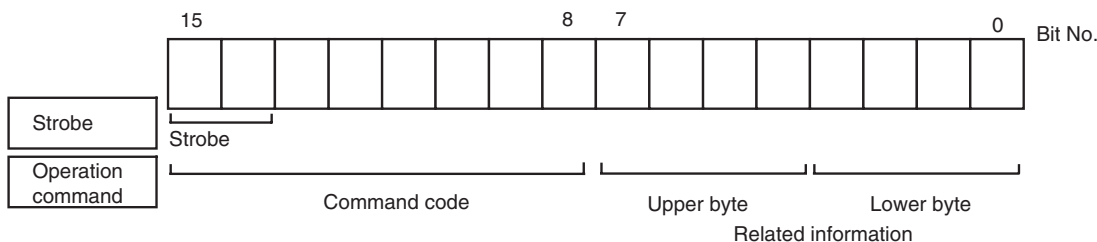

Bit 15 is strobe 2 and bit 14 is strobe 1. A logical OR is taken between the two leftmost bits of the command code and bits 15 and 14, and the result is attached as the strobe to the operation command. The command code for K3HB-DRT operation commands is 0 hex, so when the logical OR is 8 hex, the strobe is ON.

Resetting with an operation command is used for the following example.

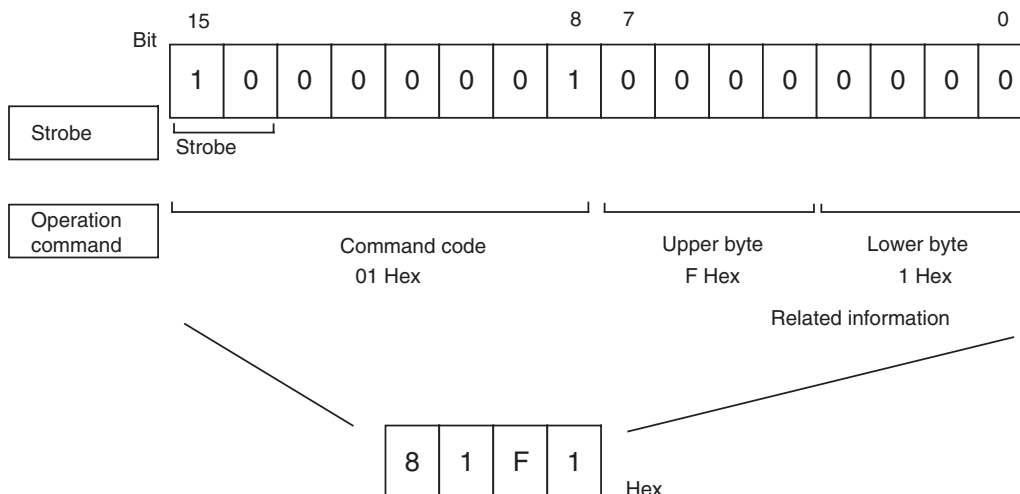

With the CS1W-DRM21 and CJ1W-DRM21 DeviceNet Units, operation commands are made ready for execution by writing to the allocated words (CIO 3202 when the default I/O allocation (fixed allocation area 1) is set.)

Operation commands are executed only when the Output Enable Bit is set to 1 (ON) and the strobe is ON. The strobe is ON when the following two conditions are met:

1. Strobe 2 = 1 and strobe 1 = 0
2. The strobe was cleared after the previous operation command was executed.

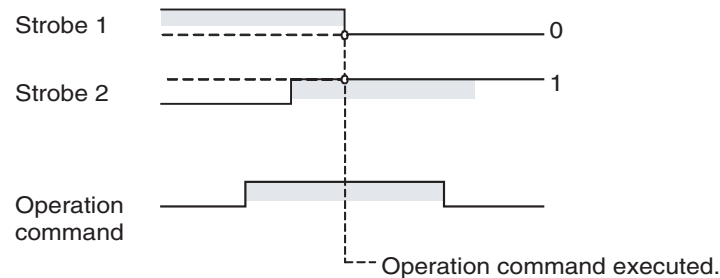

Note Software resets are executed again even if the strobe has not been cleared. Therefore the Output Enable Bit or the strobe must be cleared after the software reset command has been sent.

4-3 Ladder Programming Examples

4-3-1 Zero Execute/Cancel Sample Programming

The zero execute/cancel ladder programming example here is executed under the following conditions.

- Using default I/O allocations to allocate data in fixed allocation area 1 of a CS/CJ-series DeviceNet Unit (OUT Area = CIO 3200 to CIO 3263, IN Area = CIO 3300 to CIO 3363).

Outline

This ladder programming example executes zero execute and zero cancel for the K3HB-DRT. Zero execute and zero cancel are executed using operation commands.

Output Enable Bit (CIO 320100) and strobe are used to execute the operation command.

Operation

- First, the Output Enable Bit is turned ON. The hexadecimal values are set to D1000 and D1001 at the start of the ladder program. These values prepare the zero cancel operation command 0300 hex and the zero execute operation command 0301 hex.
- Zero cancel is executed when CIO 000000 turns ON.
- The contents of D1000 (= 0300 hex) is copied to CIO 3202, where the operation command is allocated.
- The strobe is turned ON (strobe 1 = 0 and strobe 2 = 1) and the operation command is executed.
- A timer is used and the strobe is disabled to 1 after 0.1 s (see note).
- Zero execute is executed in the same way as for zero cancel when CIO 000100 turns ON.

- Note** When using this type of ladder programming, do not use the timer method used in this example. Instead, allocate the status and confirm that the value has changed and then disable the strobe, specifically:
- a. Allocate status in the IN Area using the Configurator.
 - b. Execute operation commands and use the status to confirm that the status has been cleared to zero and then disable the strobe.

■ Programming Example

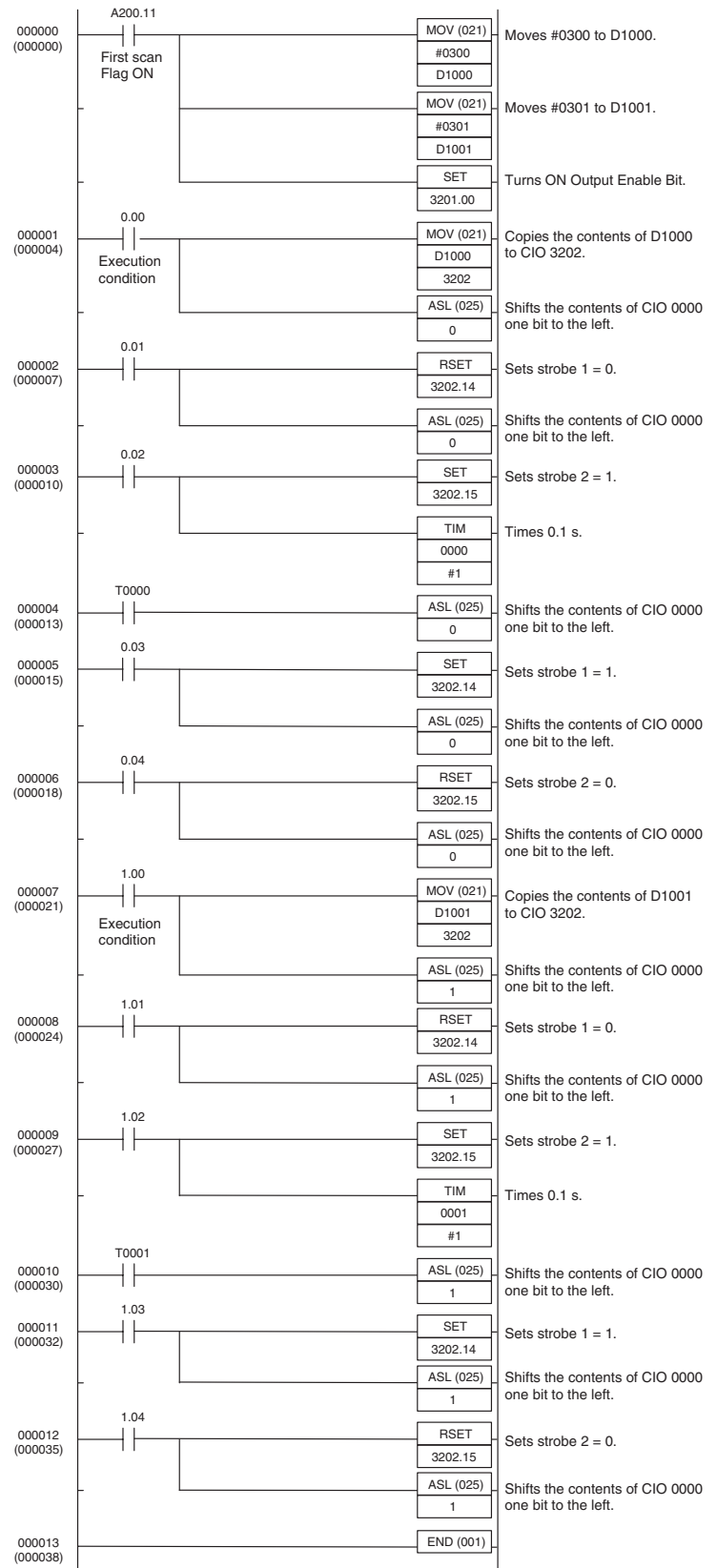

Remote I/O Communications

SECTION 5

Explicit Message Communications

This section describes how to send explicit messages to the K3HB-DRT Digital Indicator, including how to send CompoWay/F commands using explicit messages.

5-1	Overview of Explicit Message Communications	7-2
5-1-1	Explicit Message Communications	7-2
5-1-2	Explicit Message Types	7-2
5-1-3	Explicit Messages Basic Format.	7-3
5-2	Sending CompoWay/F Commands to the Digital Indicator	7-4
5-2-1	CompoWay/F Binary Commands.	7-5
5-2-2	CompoWay/F ASCII Commands	7-5
5-3	Explicit Messages Specific to DeviceNet-compatible Digital Indicators.	7-6
5-3-1	Reading General Status.	7-7
5-3-2	Writing Maintenance Mode Data	7-7
5-3-3	Setting and Monitoring the Digital Indicator Words	7-7

5-1 Overview of Explicit Message Communications

5-1-1 Explicit Message Communications

Explicit message communications is a communications protocol for sending commands from the master as explicit messages, and receiving explicit messages as responses from the nodes that receive the commands.

Explicit messages can be sent from the master to the Digital Indicator to read and write the K3HB-DRT Digital Indicator variable area, send operation commands, and read and write various other DeviceNet functions supported by the Digital Indicator.

Explicit message communications can be used to send and receive data that is not allocated in the IN and OUT Areas due to word size restrictions, and data that does not require the frequent refreshing used by the IN Area and OUT Area.

Use either of the following two methods depending on the application.

Reading/Writing K3HB-DRT Variable Area Data and Sending Operation Commands

Send CompoWay/F communications commands to K3HB-DRT Digital Indicators by embedding them in explicit messages.

Reading/Writing K3HB-DRT Maintenance Information

Send explicit messages specific to the DeviceNet-compatible Digital Indicator.

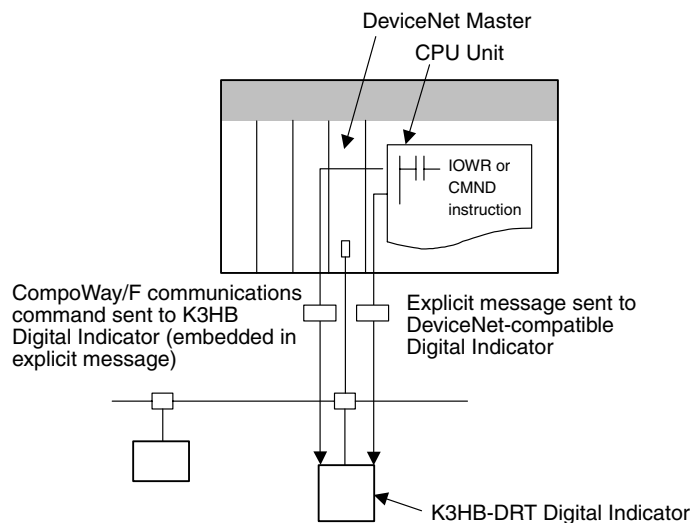

5-1-2 Explicit Message Types

The explicit messages sent to the Digital Indicator can be divided into two types: messages in which CompoWay/F commands are embedded and messages specific to DeviceNet-compatible Digital Indicators.

Sending CompoWay/F Commands to the K3HB-DRT (Embedded in Explicit Messages)

The master can send CompoWay/F communications commands to the K3HB-DRT Digital Indicator by sending them as explicit message data.

When DeviceNet-compatible Digital Indicators are used, the explicit messages are automatically converted to CompoWay/F communications commands and sent to the K3HB-DRT Digital Indicator. The responses from the Digital Indicator are converted into explicit messages and returned to the master. CompoWay/F commands are used to read from and write to the K3HB-DRT variable area and to execute operation commands.

CompoWay/F commands consist of binary commands and ASCII commands.

■ **CompoWay/F Binary Commands**

CompoWay/F binary commands are CompoWay/F communications commands expressed in hexadecimal, and are easy to execute from ladder programs. CompoWay/F communications commands that include ASCII data, however, cannot be sent or received. Therefore, Read Controller Attribute (05 03) and broadcasting (unit number = XX) cannot be used.

■ **CompoWay/F ASCII Commands**

CompoWay/F ASCII commands are CompoWay/F communications commands expressed in ASCII, so numerical values must be converted to ASCII when executing these commands from a ladder program. CompoWay/F binary commands cannot be used. Broadcasting (unit number = XX) cannot be used, but all other CompoWay/F communications commands can be sent and received, including Read Controller Attribute (05 03), which cannot be used with CompoWay/F binary commands.

Sending Explicit Messages Specific to DeviceNet-compatible Digital Indicators

The master can send explicit messages to a DeviceNet-compatible Digital Indicator to control various operations supported only by DeviceNet-compatible Digital Indicators and to read DeviceNet-specific settings and status information.

These explicit messages are used to read and write maintenance information specific to DeviceNet-compatible Digital Indicators.

5-1-3 Explicit Messages Basic Format

The basic formats of explicit message commands and responses are described here.

Command Block

Destination node address	Service code	Class ID	Instance ID	Attribute ID	Data
--------------------------	--------------	----------	-------------	--------------	------

Destination Node Address

This parameter specifies the node address of the Controller to which the explicit messages (commands) will be sent in single-byte (2-digit) hexadecimal.

Service Code, Class ID, Instance ID, Attribute ID

These parameters specify the command type, processing target, and processing details.

The Attribute ID does not need to be specified for some commands.

Data

Specifies the details of the commands, set values, etc. The data section is not required for read commands.

Response Block

The following format is used when a normal response is returned for the sent explicit message.

No. of bytes received	Source node address	Service code	Data
-----------------------	---------------------	--------------	------

The following format is used when an error response is returned for the sent explicit message.

No. of bytes received 0004 hex, fixed	Source node address	Service code	Error code (2 bytes, fixed)
--	---------------------	--------------	--------------------------------

Number of Bytes Received

The number of data bytes received from the source node address is returned as a hexadecimal. When an error response is returned for the explicit message, the contents is always 0004 hex.

Source Node Address

The node address of the master that sent the explicit message is returned as a hexadecimal.

Service Code

For normal responses, the service code specified in the command turns with the most significant bit (bit 07) turned ON is returned. (For example, when the service code of the command is 0E hex, the service code of the response will be 8E hex.) When an error response is returned for the explicit message, the service code is always 94 hex.

Data

Read data is included in the response only when a read command is executed. There is no data for commands that do not read data.

Error Code

The following table shows the error codes for explicit messages.

Error code	Error name	Cause
08FF	Service not supported	The service code is incorrect.
09FF	Invalid Attribute value	The Attribute Value is not supported.
16FF	Object does not exist	The Instance ID is not supported.
15FF	Too much data	The data string is too long.
13FF	Not enough data	The data string is too short.
14FF	Attribute not supported	The Attribute ID is not supported.
0CFF	Object state conflict	The command cannot be executed.
0EFF	Attribute not settable	A write service code was sent for a read-only Attribute ID.
20**	Invalid Parameter	There is an error in the specified parameter.

5-2 Sending CompoWay/F Commands to the Digital Indicator

The master can send CompoWay/F command frames to the K3HB-DRT Digital Indicator by embedding them in explicit message commands, and receive CompoWay/F response frames that are embedded in explicit messages responses.

The following services, however, cannot be used.

- Monitor value/set data composite registration read
- Monitor value/set data composite read registration (write)
- Monitor value/set data composite read registration confirmation (read)

5-2-1 CompoWay/F Binary Commands

CompoWay/F binary commands use hexadecimal values for the CompoWay/F frames, and not ASCII. Therefore, the data volume is about half of CompoWay/F ASCII commands. The following restrictions apply.

- Read Controller Attribute (05 03), which includes ASCII in the CompoWay/F frame, cannot be used.

The following command and response formats are used when executing CompoWay/F binary commands from an OMRON Master.

Command Block

Destination node address	Service Code	Class ID	Instance ID	Data (CompoWay/F command frame data)	
	36 hex fixed	0086 hex fixed	0001 hex fixed		
1 byte	1 byte	2 bytes	2 bytes	Specified in binary	
		Unit No. (See note.)	Sub-address	SID	FINS-mini command text
			00 hex fixed	00 hex fixed	

Note Specify the same value as the destination node address. Broadcasting cannot be specified.

Response Block

Normal Response

No. of received bytes	Source node address	Service Code	Data (CompoWay/F response frame data)	
		B6 hex fixed		
2 bytes	1 byte	1 byte	Responds in binary (hexadecimal)	
	Unit No.	Sub-address	End code	FINS-mini response text
		00 hex fixed	00 hex fixed	

5-2-2 CompoWay/F ASCII Commands

When CompoWay/F ASCII commands are used, the CompoWay/F frames are expressed in ASCII (each digit in a specified numerical value is also converted to ASCII, so 52 is specified as ASCII 3532).

The following command and response formats are used when the commands are executed from an OMRON Master Unit.

Command Block

Destination node address	Service Code	Class ID	Instance ID	Data (CompoWay/F command frame data)
1 byte	37 hex fixed 1 byte	0086 hex fixed 2 bytes	0001 hex fixed 2 bytes	Specified in ASCII
Unit No. (See note.)		Sub-address	SID	FINS-mini command text
		[00]= 3030 hex fixed	[0]= 30 hex fixed	

Note Specify the same value as the destination node address. Broadcasting cannot be specified.

Response Block

Normal Response

No. of receive bytes	Source node address	Service Code	Data (CompoWay/F response frame data)
2 bytes	1 byte	B7 Hex fixed 1 byte	Returns in ASCII
Unit No.		Sub-address	End code
		[00]= 3030 Hex fixed	FINS-mini response text

5-3 Explicit Messages Specific to DeviceNet-compatible Digital Indicators

The following list shows explicit messages that can be sent to K3HB-DRT Digital Indicators. These messages are used to read and write maintenance information (such as Unit conduction time) for the DeviceNet-compatible Digital Indicator.

For details on sending explicit messages from an OMRON Master PLC, refer to the DeviceNet Master Unit operation manual.

Note The number of digits used for the Class ID, Instance ID, and Attribute ID depends on the master used. When sending parameters from an OMRON Master Unit, the values are expressed as follows:

- Class ID: 4-digit (2-byte) hexadecimal
- Instance ID: 4-digit (2-byte) hexadecimal
- Attribute ID: 2-digit (1-byte) hexadecimal

5-3-1 Reading General Status

Explicit message	Read/write	Function	Command					Response
			Service code	Class ID	Instance ID	Attribute ID	Data size	
General Status Read	Read	Reads the DeviceNet-compatible Digital Indicator's general status bits (8 bits). (Refer to page 6-5).	0E hex	95 hex	01 hex	65 hex	---	1 byte

5-3-2 Writing Maintenance Mode Data

Explicit message	Read/write	Function	Command					Response
			Service code	Class ID	Instance ID	Attribute ID	Data size	
Maintenance Counter Save	Save	Records the maintenance counter (PV of Unit conduction time for all Digital Indicators) in memory.	16 hex	95 hex	01 hex	75 hex	---	---

5-3-3 Setting and Monitoring the Digital Indicator Words

Explicit message	Read/write	Function	Command					Response
			Service code	Class ID	Instance ID	Attribute ID	Data size	
Set Value for Unit Conduction Time	Read	Reads the set value (monitor value) for the Unit conduction time (unit: 0.1 h (6 min)).	0E hex	7A hex	01 hex	68 hex		4 bytes 00000000 to FFFFFFFF hex (0 to 4294967295)
	Write	Writes the set value (monitor value) for the Unit conduction time (unit:0.1 h (6 min)).	10 hex	7A hex	01 hex	68 hex	4 bytes 00000000 to FFFFFFFF hex (0 to 4294967295)	
Unit Conduction Time Read	Read	Reads the PV for the Unit conduction time (unit: 0.1 h (6 min)).	0E hex	7A hex	01 hex	66 hex		4 bytes 00000000 to FFFFFFFF hex (0 to 4294967295)
Monitor Status of Unit Conduction Time Read	Read	Reads the monitor status for the Unit conduction time.	0E hex	7A hex	01 hex	67 hex		1 byte 00 hex: Within range 01 hex: Out of range (monitor value exceeded)

SECTION 6

Communications Performance

This section provides information on the time required for a complete communications cycle, for an output response to be made to an input, to start the system, and to send messages.

6-1	Remote I/O Communications Performance	8-2
6-1-1	I/O Response Time	8-2
6-1-2	Communications Cycle time and Refresh Processing Time	8-3
6-1-3	Networks with More Than One Master	8-4
6-2	Message Communications Performance	8-6
6-2-1	Message Communications Time	8-6

6-1 Remote I/O Communications Performance

The performance of remote I/O communications between an OMRON Master Unit and OMRON Slave is described in this section. Use this information for reference with precise timing is required.

The following conditions are assumed in the calculations provided in this section.

- The Master Unit is operating with the scan list enabled.
- All required slaves are participating in communications.
- No error has occurred in the Master Unit.
- No messages are being sent on the network by Configurators or other devices from other manufacturers.

Note The calculations given in the section may not be accurate if a master from another manufacturer is used or if slaves from other manufacturers are used on the same network.

6-1-1 I/O Response Time

The I/O response time is the time required from when the master is notified of an input on an input slave until an output is made on an output slave (including ladder diagram processing in the PLC).

CS/CJ-series,
C200HX/HG/HE (-Z), and
C200HS PLCs

Minimum I/O Response Time

The minimum I/O response time occurs when the slave I/O refresh is performed immediately after the input is received by the master and the output is sent to the output slave at the beginning of the next I/O refresh.

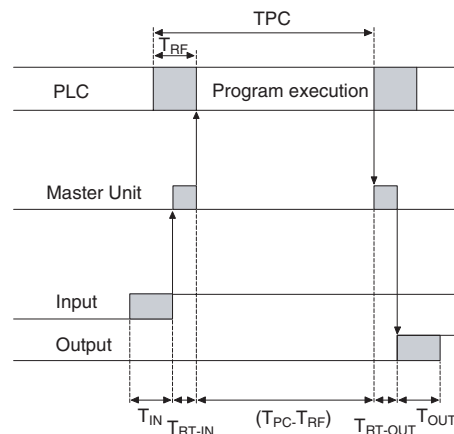

- T_{IN}: ON/OFF delay time of the input slave (0 used as minimum value)
- T_{OUT}: ON/OFF delay time of the output slave (0 used as minimum value)
- T_{RT-IN}: Communications time for one slave for input slaves
- T_{RT-OUT}: Communications time for one slave for output slaves
- T_{PC}: Cycle time of PLC
- T_{RF}: DeviceNet Unit refresh time at PLC

Note Refer to the operation manuals for the slaves for the input slave ON/OFF delay times and the output slave ON/OFF delay times. Refer to 6-1-2 *Communications Cycle time and Refresh Processing Time* and to the operation manual for the PLC for the PLC cycle time.

The minimum I/O refresh time can be calculated as follows:

$$T_{\text{MIN}} = T_{\text{IN}} + T_{\text{RT-IN}} + (T_{\text{PC}} - T_{\text{RF}}) + T_{\text{RT-OUT}} + T_{\text{OUT}}$$

Maximum I/O Response Time

The maximum I/O response time occurs under the conditions shown in the following diagram.

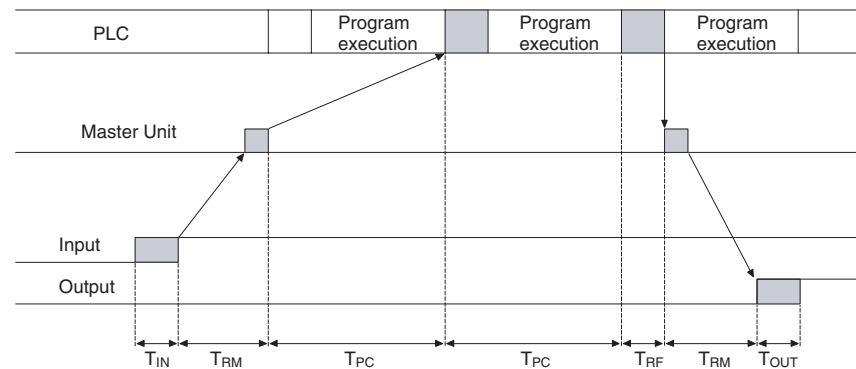

- T_{IN} : ON/OFF delay time of the input slave (0 used as minimum value)
 T_{OUT} : ON/OFF delay time of the output slave (0 used as minimum value)
 T_{RM} : Communications time for entire network
 T_{PC} : Cycle time of PLC
 T_{RF} : DeviceNet Unit refresh time at PLC

Note Refer to the operation manuals for the slaves for the input slave ON/OFF delay times and the output slave ON/OFF delay times. Refer to 6-1-2 *Communications Cycle time and Refresh Processing Time* and to the operation manual for the PLC for the PLC cycle time.

The maximum I/O refresh time can be calculated as follows:

$$T_{MAX} = T_{IN} + 2 \times T_{RM} + 2 \times T_{PC} + T_{RF} + T_{OUT}$$

6-1-2 Communications Cycle time and Refresh Processing Time

This section describes the communications cycle time and refresh processing time, which are required to calculate various processing times for DeviceNet.

Communications Cycle Time

The communications cycle time is the time from the completion of a slave's I/O communications processing until I/O communications with the same slave are processed again. The communications cycle time is the maximum communications cycle time $T_{IN} + T_{OUT}$.

The equations used to calculate the communications cycle time are described here.

Communications Cycle Time Equations

Total communications cycle time = IN communications cycle time + OUT communications cycle time.

■ IN Communications Cycle Time

IN communications cycle time = (39 ms + 8 ms x number of allocated data) + (6 ms x total allocated words in IN Areas 1 and 2)

■ OUT Communications Cycle Time

OUT communications cycle time = (29 ms + 27 ms x number of allocated data) + (7 ms x total allocated words in OUT Areas 1 and 2)

Refresh Processing Time

The refresh processing time is the time required for the CPU Unit of the PLC and the DeviceNet Master Unit to pass I/O information back and forth. The cycle time of the PLC is affected as described below when a DeviceNet Unit is mounted.

Note Refer to the operation manuals for the PLCs for details on the refresh processing time and the PLC's cycle time.

CS/CJ-series, C200HX/HG/HE (-Z), and C200HS PLCs

The following times for I/O refreshing are added to the cycle time of the PLC when a Master Unit is mounted.

Item	Processing time
I/O refresh	DeviceNet Unit I/O Refresh Processing CS/CJ-series or C200HX/HG/HE (-Z) PLCs $1.72 + 0.022 \times \text{number of allocated words (see note) ms}$ C200HS PLCs $2.27 + 0.077 \times \text{number of allocated words (see note) ms}$

Note The number of allocated words is the total number of I/O area words allocated to all of the slaves. Any unused areas within the allocations must be included. For example, if only node address 1 with a 1-word input and node address 5 with a 1-word input are connected, the total number of words would be 5. When message communications are performed, the number of words required for message communications would have to be added to the above total number of words during the cycles in which message communications are processed.

6-1-3 Networks with More Than One Master

The communications cycle time, T_{RM} , when there is more than one master in the same network is described in this section. Here, a network with two masters is used as an example.

First, separate the network into two groups, slaves that perform remote I/O communications with master A and those that perform remote I/O communications with master B.

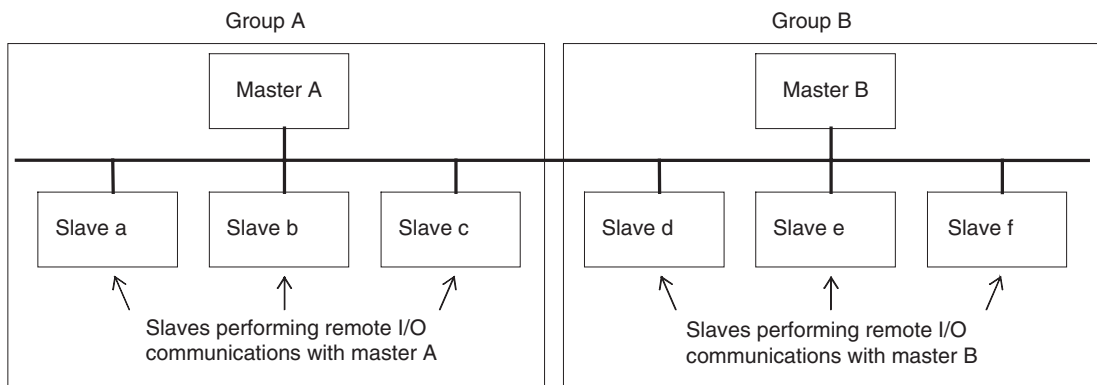

Note Although for convenience, the slave are positioned in groups with the masters, in the actual network, the physical positions of the slaves will not necessarily be related to the master with which they communicate.

Communications Performance

Next, calculate the communications cycle time for each group referring to 6-1-2 Communications Cycle time and Refresh Processing Time.

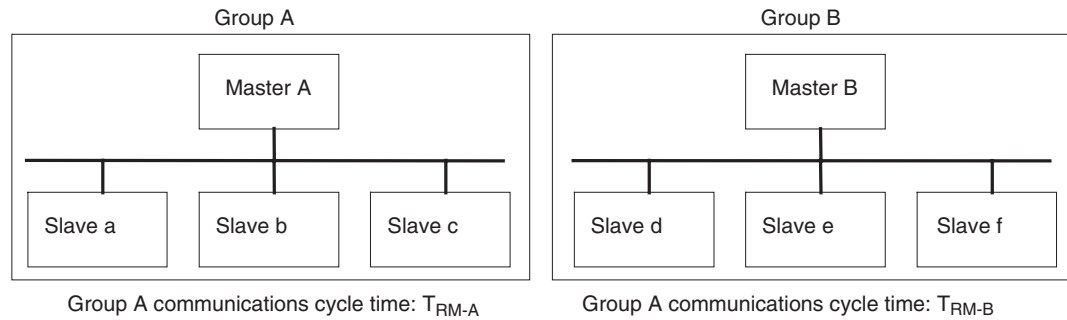

The communications cycle time for the overall network when there are two masters will be as follows:

$$T_{RM} = T_{RM-A} + T_{RM-B}$$

Although this example uses a network with only two masters, the same method can be used for any number of masters. Simply divide the network up according to remote I/O communications groups and then add all of the communications cycle times for the individual groups to calculate the communications cycle time for the overall network.

System Startup Time

This section describes the system startup time for a Network, assuming that the scan list is enabled and that remote I/O communications are set to start automatically at startup. The system startup time is the delay from the time that the Master Unit is turned ON or restarted until the time remote I/O communications begin.

The system startup time when the Master Unit is set to start up immediately after power supplies of all the slaves are turned ON is different from when the Master Unit is restarted while communications are in progress. The startup times are shown in the following table.

Condition	Slave's indicator status	System startup time
The master is started immediately after slave startup.	NS indicator is OFF or flashing green.	6 s
The master only is restarted.	NS indicator is flashing red while the master is OFF.	8 s
The slaves only are restarted.	---	10 s

Sample Program

The times described above are required for the DeviceNet system to start. The sample program in this section shows how to use the Master Slave Status to skip slave I/O processing until remote I/O communications have started.

Note Refer to the operation manual for the Master Unit for information on the Master Status Area.

The following conditions apply to this sample program.

PLC: CS1 Series

Master Unit's unit number: 00

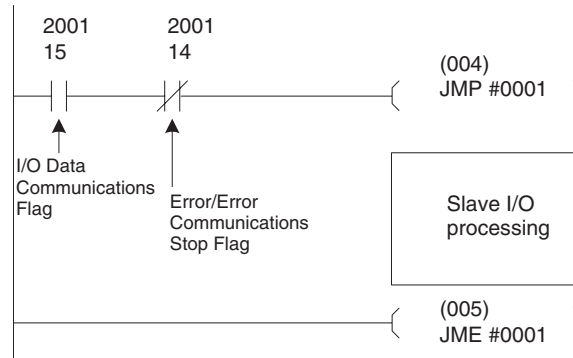

6-2 Message Communications Performance

6-2-1 Message Communications Time

The message communications time is the time required from when the Master Unit starts to send a message on the network until the entire message has been sent when a message is being sent from one node to another. The message will consist of data for a SEND or RECV instruction and a FINS command for an IOWR or CMND instruction.

Note If another message is sent before the message communications time elapses or is a message is received from another node before the message communications time elapses, the response message being sent or the message being received may be corrupted. When performing message communications it is thus necessary to allow the message communications time to elapse before performing message communications again using SEND, RECV, CMND, or IOWR instructions and to allow the message communications time to elapse between sending messages to the same node. If a send or receive message is corrupted, a record will be stored in the error log in the Master Unit. Use a FINS command to read the error record or use the Configurator to monitor the error log.

The message communications time can be estimated using the following equation:

$$\text{Message communications time} = \text{Communications cycle time} \times \{(\text{number of message bytes} + 15) \div 6 + 1\}$$

The number of message bytes in the number of bytes after the FINS command code. The communications cycle time will depend on whether remote I/O communications is being used and can be calculated as described next.

Only Message Communications (Remote I/O Communications Stopped)

Communications cycle time = 2 (see note) + 0.11 x TB + 0.6 ms

TB depends on the baud range as follows:

500 KB/s: 2, 250 KB/s: 4, 125 KB/s: 8

Note The communications cycle time when remote I/O communications are stopped is 2 ms.

Message Communications and Remote I/O Communications

Communications cycle time = (communications cycle time for only remote I/O communications + 0.11 x TB + 0.6 ms

TB depends on the baud range as follows:

500 KB/s: 2, 250 KB/s: 4, 125 KB/s: 8

Note The above calculations for the message communications times are only for use as guidelines. They do not produce maximum values. The message communications time depends on the frequency of messages, the load on the remote node, the communications cycle time, etc. If network traffic is concentrated on one Master Unit, long times will be required that those produced by the above calculations. Be sure to consider this when designing the system.

SECTION 7

Troubleshooting and Maintenance

This section describes error processing, periodic maintenance operations, and troubleshooting procedures needed to keep the DeviceNet Network operating properly. Details on resetting replaced Digital Indicators are also provided. Read through the error processing procedures in both this manual and the operation manual for the DeviceNet master being used before operation so that operating errors can be identified and corrected more quickly.

7-1	Indicators and Error Processing	9-2
7-2	Maintenance	9-3
7-2-1	Cleaning	9-3
7-2-2	Inspection	9-3
7-2-3	Replacing Digital Indicators	9-4

7-1 Indicators and Error Processing

The following table lists the indicator status when errors occur, the probable causes and processing.

Indicator status	Probable cause	Remedy
MS: OFF NS: OFF	The power is not being supplied to the Digital Indicator.	Supply communications power from the DeviceNet connector.
	The power voltage is not within the permitted range.	Use a power supply voltage within the permitted range.
	The Digital Indicator is faulty.	Replace the Digital Indicator.
MS: Flashing red NS: No change	A checksum error has occurred in the parameters registered in EEPROM.	Repairs are required if this error persists even if the parameters are reset. Contact your nearest OMRON representative.
	A EEPROM hardware error has occurred.	
MS: ON red NS: OFF	The Digital Indicator is faulty.	Repairs are required. Contact your nearest OMRON representative.
MS: ON green NS: Flashing green	Waiting to connect to DeviceNet communications.	Check the following items and restart the Digital Indicator. <ul style="list-style-type: none"> • Are lengths of cables (trunk and branch lines) correct? • Are cables short-circuited, broken, or loose? • Are cables wired correctly? • Is terminating resistance connected to both ends of the trunk line only? • Is noise interference excessive? • Is the power to the master ON?
	The Digital Indicator is faulty.	Repairs are required. Contact your nearest OMRON representative.
MS: ON green NS: ON red	The DeviceNet is in Bus Off status.	Check the following items and restart the Digital Indicator. <ul style="list-style-type: none"> • Are lengths of cables (trunk and branch lines) correct? • Are cables short-circuited, broken, or loose? • Is terminating resistance connected to both ends of the trunk line only? • Is noise interference excessive?
	Node addresses duplicated.	Reset node addresses correctly.
	The Digital Indicator is faulty.	Repairs are required. Contact your nearest OMRON representative.
MS: ON green NS: Flashing red	A communications timeout has occurred.	Check the following items and restart the Digital Indicator. <ul style="list-style-type: none"> • Are lengths of cables (trunk and branch lines) correct? • Are cables short-circuited, broken, or loose? • Is terminating resistance connected to both ends of the trunk line only? • Is noise interference excessive?
	The Digital Indicator is faulty.	Repairs are required. Contact your nearest OMRON representative.

7-2 Maintenance

This section describes the routine cleaning and inspection recommended as regular maintenance. Handling methods when replacing Digital Indicators are also explained here.

7-2-1 Cleaning

Clean the Digital Indicators regularly as described below in order to keep the Network in its optimal operating condition.

- Wipe the Digital Indicator with a dry, soft cloth for regular cleaning.
- When dust or dirt cannot be removed with a dry cloth, dampen the cloth with a neutral cleanser (2%), wring out the cloth, and wipe the Digital Indicator.
- Smudges may remain on the Digital Indicator from gum, vinyl, or tape that was left on for a long time. Remove these smudges when cleaning.

Note Never use volatile solvents, such as paint thinner or benzene, or chemical wipes to clean the Digital Indicator. These substances may damage the surface of the Digital Indicator.

7-2-2 Inspection

Inspect the system periodically to keep it in its optimal operating condition.

In general, inspect the system once every 6 to 12 months, but inspect more frequently if the system is used in high-temperature, humid, or dusty conditions.

Inspection Equipment

Equipment Required for Regular Inspection

Prepare the following equipment before inspecting the system.

A flat-blade and a Phillips screwdriver, a screwdriver for connecting communications connectors, a tester (or a digital voltmeter), industrial alcohol, and a clean cloth are required for routine inspection.

Other Equipment that May Be Required

A synchroscope, oscilloscope, thermometer, or hygrometer may be required.

Inspection Procedure

Check the items in the following table and correct any condition that is below standard by adjusting the Digital Indicator or improving the environmental conditions.

Inspection item	Details	Standard	Equipment
Environmental conditions	Are ambient and cabinet temperatures correct?	-10 to +55°C	Thermometer
	Are ambient and cabinet humidity correct?	25% to 85%	Hygrometer
	Has dust or dirt accumulated?	No dust or dirt	Visual inspection
Installation conditions	Are the connectors of the communications cables fully inserted?	No looseness	Phillips screwdriver
	Are the external wiring screws tight?	No looseness	Phillips screwdriver
	Are the connecting cables undamaged?	No external damage	Visual inspection

7-2-3 Replacing Digital Indicators

The Network consists of the DeviceNet Master Unit and Slave Units. The entire network is affected when a Unit is faulty, so a faulty Unit must be repaired or replaced quickly. We recommend having spare Units available to restore Network operation as quickly as possible.

Precautions

Observe the following precautions when replacing a faulty Digital Indicator.

- After replacement make sure that there are no errors with the new Digital Indicator.
- When a Digital Indicator is being returned for repair, attach a sheet of paper detailing the problem and return the Digital Indicator to your OMRON dealer.
- If there is a faulty contact, try wiping the contact with a clean, lint-free cloth dampened with alcohol.

Note Before replacing a Digital Indicator, always stop Network communications and turn OFF the power to all the nodes in the Network.

SECTION 8

Additional Information for DeviceNet

8-1	Detailed DeviceNet Specifications	10-2
8-2	Mounted Objects	10-3
8-3	DeviceNet Connection Hardware	10-7
8-4	Glossary	10-10

8-1 Detailed DeviceNet Specifications

Data Size and Connection Types

If the connection type can be set when another company's configurator is being used, select a connection supported by the DeviceNet Communications Unit.

The following table shows the connection types and data sizes for OMRON DeviceNet Communications Units.

Model	Supported connections				Data size (bytes)	
	Poll	Bit strobe	Change of state (COS)	Cyclic	IN	OUT
K3HB-DRT	Yes	Yes	Yes	Yes	1 to 120 (See note.)	1 to 58 (See note.)

Note The size of the IN/OUT Areas depends on the setting.

DeviceNet I/O communications support the following types of connections.

Connection type	Details	Remarks
Poll	Used to exchange data between the master and individual slaves by sending and receiving commands and responses. (Output data is allocated for commands and input data is allocated for responses).	---
Bit strobe	Used to broadcast commands from the master and receive input responses from multiple slaves.	By using one command only, the communications cycle time is short, but bit strobe connections can be used only with slaves with 8 or less input points.
Change of state (COS)	Normally, input and output data are sent by master and slaves at regular cycles, but with a COS connection, data is sent to the master or slave when the master or slave data changes.	By setting a long cycle interval, the Network will not be loaded with communications for minor data changes, thereby improving the overall efficiency of the Network.
Cyclic	Masters and slaves send output or input data at regular cycles.	

Device Profiles

The following device profiles contain more detailed DeviceNet specifications for DeviceNet communications if more information needs to be registered in the scan list.

General data	Compatible DeviceNet Specifications	Volume I - Release 2.0 Volume II - Release 2.0	
	Vendor name	OMRON Corporation	Vendor ID = 47
	Device profile name	Slaves: Generic Device	Profile number = 0
	Manufacturer catalog number	N129	
	Manufacturer revision	1.01	
Physical conformance data	Network current consumption	50 mA max.	
	Connector type	Open plug	
	Physical layer insulation	No	
	Supported indicators	Module, Network	
	MAC ID setting	Software switch	
	Default MAC ID	1	
	Baud rate setting	Automatic recognition	
Communications data	Supported baud rates	125 kbps, 250 kbps, and 500 kbps	
	Predefined Master/Slave connection set	Group 2 only server	
	Dynamic connection support (UCMM)	No	
	Explicit message fragmentation support	Yes	

8-2 Mounted Objects

Identity Object (0x01)

Object class	Attribute	Not supported
	Service	Not supported

Object instance	Attribute	ID	Contents	Get (read)	Set (write)	Value
		1	Vendor	No	No	47
2	Device type	Yes	No	0		
3	Product code	Yes	No	505		
4	Revision	Yes	No	1.1		
5	Status (bits supported)	Yes	No	Bit 00 only		
6	Serial number	Yes	No	Unique for each Unit		
7	Product name	Yes	No	K3HB-DRT		
8	State	No	No			
	Service	DeviceNet service		Parameter option		
05		Reset	No			
0E		Get_Attribute_Single	No			

Message Router Object (0x02)

Object class	Attribute	Not supported
	Service	Not supported
Object instance	Attribute	Not supported
	Service	Not supported
Vendor specification addition		None

DeviceNet Object (0x03)

Object class	Attribute	Not supported
	Service	Not supported

Object instance	Attribute	ID	Contents	Get (read)	Set (write)	Value
		1	MAC ID	No	No	
		2	Baud rate	Yes	No	
		3	BOI	Yes	No	00 (hexadecimal)
		4	Bus Off counter	No	No	
		5	Allocation information	Yes	No	
	Service	DeviceNet service		Parameter option		
0E		Get_Attribute_Single	None			
4B		Allocate_Master/ Slave_Connection_Set	None			
4C		Release_Master/ Slave_Connection_Set	None			

Assembly Object (0x04)

Object class	Attribute	Not supported
	Service	Not supported

Object instance	Attribute	ID	Contents	Get (read)	Set (write)	Value
100: IN Area 1		1	Number of members in list	No	No	
101: IN Area 2		2	Member list	No	No	
110: OUT Area 1		3	Data	Yes	No	
	Service	DeviceNet service		Parameter option		
		0E	Get_Attribute_Single	None		

Connection Object (0x05)

Object class	Attribute	Not supported
	Service	Not supported
	Maximum number of active connections	1

Object instance 1	Section	Information		Maximum number of instances		
		Instance type	Explicit Message		1	
	Production trigger	Cyclic				
	Transport type	Server				
	Transport class	3				
	Attribute	ID	Contents	Get (read)	Set (write)	Value
		1	State	Yes	No	
		2	Instance type	Yes	No	00 (hexadecimal)
		3	Transport class trigger	Yes	No	83 (hexadecimal)
		4	Produced connection ID	Yes	No	
		5	Consumed connection ID	Yes	No	
		6	Initial comm. characteristics	Yes	No	21 (hexadecimal)
		7	Produced connection size	Yes	No	0176 (hexadecimal)
		8	Consumed connection size	Yes	No	
		9	Expected packet rate	Yes	Yes	01 (hexadecimal)
		12	Watchdog time-out action	Yes	No	01 (hexadecimal)
		13	Produced connection path length	Yes	No	00 (hexadecimal)
		14	Produced connection path	Yes	No	
		15	Consumed connection path	Yes	No	00 (hexadecimal)
	Service	DeviceNet service		Parameter option		
	05	Reset		None		
	0E	Get_Attribute_Single		None		
	10	Set_Attribute_Single		None		

Object instance 2	Section	Information		Maximum number of instances		
	Instance type	Polled I/O		1		
	Production trigger	Cyclic				
	Transport type	Server				
	Transport class	2				
Attribute	ID	Contents	Get (read)	Set (write)	Value	
	1	State	Yes	No		
	2	Instance type	Yes	No	01 (hexadecimal)	
	3	Transport class trigger	Yes	No	82 (hexadecimal)	
	4	Produced connection ID	Yes	No		
	5	Consumed connection ID	Yes	No		
	6	Initial comm. characteristics	Yes	No	01 (hexadecimal)	
	7	Produced connection size	Yes	No		
	8	Consumed connection size	Yes	No		
	9	Expected packet rate	Yes	Yes		
	12	Watchdog time-out action	Yes	No	00 (hexadecimal)	
	13	Produced connection path length	Yes	No	06 (hexadecimal)	
	14	Produced connection path	Yes	No	See note 1.	
	15	Consumed connection path length			06 (hexadecimal)	
	16	Consumed connection path	Yes	No	See note 2.	
	17	Production inhibit time	Yes	No	0000 (hexadecimal)	
Service	DeviceNet service		Parameter option			
	05	Reset	None			
	0E	Get_Attribute_Single	None			
	10	Set_Attribute_Single	None			

1. Produced Connection Paths
 IN Area 1: 20_04_24_64_30_03
 IN Area 2: 20_04_24_65_30_03
2. Consumed Connection Paths
 OUT Area: 20_04_24_6E_30_03

Object instance 4	Section	Information		Maximum number of instances		
	Instance type	COS Cyclic		1		
	Production trigger	Cyclic				
	Transport type	Server				
	Transport class	2				
Attribute	ID	Contents	Get (read)	Set (write)	Value	
	1	State	Yes	No		
	2	Instance type	Yes	No	01 (hexadecimal)	
	3	Transport class trigger	Yes	No	12 (hexadecimal)	
	4	Produced connection ID	Yes	No		
	5	Consumed connection ID	Yes	No		
	6	Initial comm. characteristics	Yes	No	01 (hexadecimal)	
	7	Produced connection size	Yes	No		
	8	Consumed connection size	Yes	No	0800 (hexadecimal)	
	9	Expected packet rate	Yes	Yes		
	12	Watchdog time-out action	Yes	No	00 (hexadecimal)	
	13	Produced connection path length	Yes	No	06 (hexadecimal)	
	14	Produced connection path	Yes	No	See note.	
	15	Consumed connection path length			04 (hexadecimal)	
	16	Consumed connection path	Yes	No	202B2401	
	17	Production inhibit time	Yes	Yes	0000 (hexadecimal)	
Service	DeviceNet service		Parameter option			
	05	Reset	None			
	0E	Get_Attribute_Single	None			
	10	Set_Attribute_Single	None			

Note Produced Connection Paths
 IN Area 1: 20_04_24_64_30_03
 IN Area 2: 20_04_24_65_30_03

8-3 DeviceNet Connection Hardware

DeviceNet Communications Cables

Model	Specifications	Manufacturer
DCA1-5C10	Thin Cable: 5 wires, 100 m	OMRON
DVN24-10G	Thin Cable: 5 wires, 10 m	Nihon Wire & Cable (See note 1.)
DVN24-30G	Thin Cable: 5 wires, 30 m	Nihon Wire & Cable (See note 1.)
DVN24-50G	Thin Cable: 5 wires, 50 m	Nihon Wire & Cable (See note 1.)
DVN24-100G	Thin Cable: 5 wires, 100 m	Nihon Wire & Cable (See note 1.)
DVN24-300G	Thin Cable: 5 wires, 300 m	Nihon Wire & Cable (See note 1.)

Additional Information for DeviceNet

Model	Specifications	Manufacturer
DVN24-500G	Thin Cable: 5 wires, 500 m	Nihon Wire & Cable (See note 1.)
1485C-P1-C150	Thin Cable: 5 wires, 150 m	Allen-Bradley (See note 2.)
DCA1-5CN□□W1	Cable with shielded micro-size (M12) connectors on both ends (female socket and male plug) Cable length: 0.5 m, 1 m, 2 m, 3 m, 5 m, and 10 m	OMRON
DCA1-5CN□□F1	Cable with shielded micro-size (M12) connector (female socket) on one end Cable length: 0.5 m, 1 m, 2 m, 3 m, 5 m, and 10 m	OMRON
DCA1-5CN□□H1	Cable with shielded micro-size (M12) connector (male plug) on one end Cable length: 0.5 m, 1 m, 2 m, 3 m, 5 m, and 10 m	OMRON
DCA1-5CN□□W5	Cable with shielded connector on both ends (male plug on mini-size end, female socket on micro-size end) Cable length: 1 m, 2 m, 5 m, and 10 m	OMRON

Note

1. The product specifications of these cables are identical to the OMRON cable specifications.
2. The cables made by Allen-Bradley are stiffer than the cables made by OMRON and Nihon Wire & Cable Company Ltd., so do not bend the Allen-Bradley cables as much as the others.

Other DeviceNet communications cables are available from the following manufacturers. For details, refer to the product catalogs on the ODVA web site (<http://www.odva.astem.or.jp/>) or contact the manufacturer directly.

DeviceNet Connector

Model	Specifications	Manufacturer
HR31-5.08P-5SC (01)	For node connection Includes connector set screws	Hirose Electric

Crimp Terminals for DeviceNet Communications Cables

Model	Manufacturer
HR31-SC-121: For Thin Cables	Hirose Electric
HR31-SC-111: For Thick Cables	

Terminating Resistors for DeviceNet Network

Model	Specifications	Manufacturer
DRS1-T	Terminal-block Terminating Resistor, $121 \Omega \pm 1\%$ 1/4 W	OMRON
DRS2-1	Shielded Terminating Resistor (male plug), micro-size (M12)	
DRS2-2	Shielded Terminating Resistor (female socket), micro-size (M12)	
DRS3-1	Shielded Terminating Resistor (male plug), mini-size	

A Terminating Resistor can also be connected to a T-branch Tap or a one-branch Power Supply Tap.

T-branch Taps

One-branch Taps

Model	Specifications	Manufacturer
DCN1-1C	Includes three XW4B-05C1-H1-D parallel connectors with screws (When used on a trunk line, one branch line can be connected.) Connector insertion direction: Horizontal A Terminating Resistor (included as standard) can be connected.	OMRON
DCN1-2C	Includes three XW4B-05C1-H1-D parallel connectors with screws (When used on a trunk line, one branch line can be connected.) Connector insertion direction: Vertical A Terminating Resistor (included as standard) can be connected.	OMRON
DCN1-2R	Includes three XW4B-05C1-VIR-D orthogonal connectors with screws (When used on a trunk line, one branch line can be connected.) Connector insertion direction: Vertical A Terminating Resistor (included as standard) can be connected.	OMRON

Three-branch Taps

Model	Specifications	Manufacturer
DCN1-3C	Includes five XW4B-05C1-H1-D parallel connectors with screws (When used on a trunk line, three branch lines can be connected.) Connector insertion direction: Horizontal A Terminating Resistor (included as standard) can be connected.	OMRON
DCN1-4C	Includes five XW4B-05C1-H1-D parallel connectors with screws (When used on a trunk line, three branch lines can be connected.) Connector insertion direction: Vertical A Terminating Resistor (included as standard) can be connected.	OMRON
DCN1-4R	Includes five XW4B-05C1-VIR-D orthogonal connectors with screws (When used on a trunk line, three branch lines can be connected.) Connector insertion direction: Vertical A Terminating Resistor (included as standard) can be connected.	OMRON

Shielded T-branch Connectors

Model	Specifications	Manufacturer
DCN2-1	One-branch shielded T-branch connectors, three micro-size (M12) connectors	OMRON
DCN3-11	One-branch shielded T-branch connectors, three mini-size connectors	
DCN3-12	One-branch shielded T-branch connectors, two mini-size connectors and one micro-size (M12) connector	

One-branch Power Supply Tap

Model	Specifications	Manufacturer
DCN1-1P	One-branch tap for power supply. Use this tap when connecting a communications power supply. Includes two XW4B-05C1-H1-D parallel connectors with screws and two fuses as standard. A Terminating Resistor (included as standard) can be connected.	OMRON

8-4 Glossary

The following table provides a list of commonly used DeviceNet terms.

Term	Explanation
Bus OFF	Indicates that the error rate in the network is extremely high. Errors are detected when a fixed threshold is exceeded by the internal error counter. (the internal error counter is cleared when the Master Unit is started or restarted.)
CAN	CAN is short for Controller Area Network. It is a communications protocol developed as a LAN for use in automobiles. DeviceNet employs CAN technology.
Configurator	A device for setting the system settings. The Configurator can read ID information, read and write parameters, and display the network configuration. OMRON's DeviceNet Configurator is designed for use with an OMRON Master Unit.
Consumed Connection Size	Indicates the data size (byte length) received via the connection.
ODVA	ODVA is short for Open DeviceNet Vendor Association, Inc. It is a non-profit organization formed by machine vendors with the aim to administer and popularize the DeviceNet specification.
Produced Connection Size	Indicates the data size (byte length) sent via the connection.
Connection	This is a logical communication channel for facilitating communications between nodes. Communications are maintained and managed between the master and slaves.
Device Profile	Standardizes the configuration and behavior (the smallest data configuration and operation that must be supported by the device) of devices of the same type (equipment, etc.). Provides mutual exchangeability between devices of the same type. Also known as a device model. Devices for which device profiles are currently being investigated include sensors, valves, display units, and encoders.
Master/Slave	A node can be either a master, which collects and distributes data, or a slave, which outputs and inputs data according to the instructions received from the master. OMRON's DeviceNet products are already provided with either master or slave functions in a pre-defined master/slave connection set.

Part 3: BCD Output

SECTION 1	BCD Communications	11-1
1-1	Features	11-2
1-2	Specifications	11-3
1-3	Accessories	11-6
1-4	Precautions for BCD Programming	11-7
1-5	Programming Example 1: Connecting to a PLC.....	11-7
1-6	Programming Example 2: Connecting to a PLC.....	11-10

Part 3: BCD Output

SECTION 1

BCD Communications

1-1	Features	11-2
1-1-1	Overview	11-2
1-1-2	Connection Example	11-2
1-2	Specifications	11-3
1-2-1	I/O Ratings	11-3
1-2-2	Pin Names	11-3
1-2-3	Pin Wiring Diagram	11-4
1-2-4	Timing Chart	11-5
1-2-5	Precautions	11-5
1-3	Accessories	11-6
1-3-1	Connectors (Included)	11-6
1-3-2	Cable: K32-BCD	11-6
1-3-3	Operating Method	11-7
1-4	Precautions for BCD Programming	11-7
1-5	Programming Example 1: Connecting to a PLC	11-7
1-5-1	I/O Allocations	11-7
1-5-2	DM (Data Memory) Area	11-8
1-5-3	Operation	11-8
1-5-4	Timing Chart	11-8
1-5-5	Ladder Programming	11-9
1-6	Programming Example 2: Connecting to a PLC	11-10
1-6-1	I/O Allocations	11-10
1-6-2	DM (Data Memory) Area	11-11
1-6-3	Operation	11-11
1-6-4	Timing Chart	11-12
1-6-5	Ladder Programming	11-13

1-2 Specifications

1-2-1 I/O Ratings

I/O signal names		Item		Rating
Input	REQ HOLD (COMPENSATION) MAX MIN RESET	Input signal		No-voltage contact input
		No-voltage input current		10 mA
		Signal level	ON voltage	1.5 V max.
			OFF voltage	3 V min.
Output	DATA POLARITY OVER DATA VALID RUN	Max. load voltage		24 VDC
		Max. load current		10 mA
		Leakage current		100 μ A
	HH (OUT5) H (OUT4) PASS (OUT3) L (OUT2) LL (OUT1)	Max. load voltage		24 VDC
		Max. load current		50 mA
		Leakage current		100 μ A

1-2-2 Pin Names

K32-BCD pin number	Digital Indicator BCD pin number	Signal name	Signal direction	Meaning
1	1	COM		GND: VO
2	3	RD1-1	Output	1 \searrow Read data 10^0 digit
3	5	RD1-2	Output	2 \searrow Read data 10^0 digit
4	7	RD1-4	Output	4 \searrow Read data 10^0 digit
5	9	RD1-8	Output	8 \searrow Read data 10^0 digit
6	11	RD2-1	Output	1 \searrow Read data 10^1 digit
7	13	RD2-2	Output	2 \searrow Read data 10^1 digit
8	15	RD2-4	Output	4 \searrow Read data 10^1 digit
9	17	RD2-8	Output	8 \searrow Read data 10^1 digit
10	19	RD3-1	Output	1 \searrow Read data 10^2 digit
11	21	RD3-2	Output	2 \searrow Read data 10^2 digit
12	23	RD3-4	Output	4 \searrow Read data 10^2 digit
13	25	RD3-8	Output	8 \searrow Read data 10^2 digit
14	26	RD4-1	Output	1 \searrow Read data 10^3 digit
15	27	RD4-2	Output	2 \searrow Read data 10^3 digit
16	28	RD4-4	Output	4 \searrow Read data 10^3 digit
17	29	RD4-8	Output	8 \searrow Read data 10^3 digit
18	30	RD5-1	Output	1 \searrow Read data 10^4 digit
19	31	RD5-2	Output	2 \searrow Read data 10^4 digit
20	32	RD5-4	Output	4 \searrow Read data 10^4 digit
21	33	RD5-8	Output	8 \searrow Read data 10^4 digit
22	34	OVER	Output	Data overflow, data underflow
23	35	D-V	Output	Data valid signal
24	36	RUN	Output	RUN signal

K32-BCD pin number	Digital Indicator BCD pin number	Signal name	Signal direction	Meaning
25	37	COM		
26	38	REQ	Input	Measurement value output request
27	39	MAX	Input	Maximum value output request
28	40	MIN	Input	Minimum value output request
29	41	HOLD (COMPENSATION)	Input	HOLD input (COMPENSATION input) See note 2.
30	42	RESET	Input	RESET input
31	43	POL	Output	Data polarity signal (- when ON, + when OFF)
32	44	HH (OUT5)	Output	Output HH (OUT5) See note 3.
33	45	H (OUT4)	Output	Output H (OUT4) See note 3.
34	46	PASS (OUT3)	Output	Output PASS (OUT3) See note 3.
35	47	L (OUT2)	Output	Output L (OUT2) See note 3.
36	48	LL (OUT1)	Output	Output LL (OUT1) See note 3.
37	49	COM		GND: V0

- Note**
- (1) Common pins 1, 25, and 37 are internally connected.
 - (2) Pin 29 is the HOLD input to the K3HB-X/V/H/S/R/P, and the COMPENSATION input to the K3HB-C.
 - (3) OUT1 to OUT5 are for the K3HB-C.

1-2-3 Pin Wiring Diagram

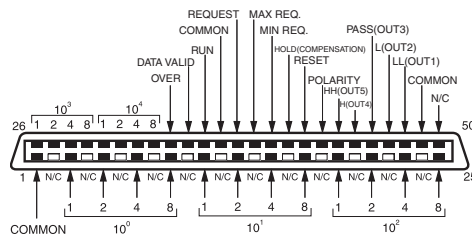

- Note**
- (1) Either of the BCD common pins can be used for any of the signals.
 - (2) Pins shown as blank in the diagram (□) have been removed.
 - (3) OUT1 to OUT3 and COMPENSATION are for the K3HB-C.
 - Applicable connector (sold separately): HDR-E50MAG1 (made by Honda Tsushin Kogyo Co., Ltd.)
 - Special cable (sold separately): K32-BCD (OMRON), (HDR-E50MAG1 and 0.3-m cable)

1-2-4 Timing Chart

Outputting Sampling Data

Data becomes valid and the Data Valid (D.V.) signal turns ON approximately 30 ms after the rising edge of the REQ signal. Read the data while the D.V. signal is ON.

The D.V. signal turns OFF after 40 ms, and then the DATA turns OFF after another 16 ms.

When reading the data from a PLC, read the data while the D.V. signal is ON.

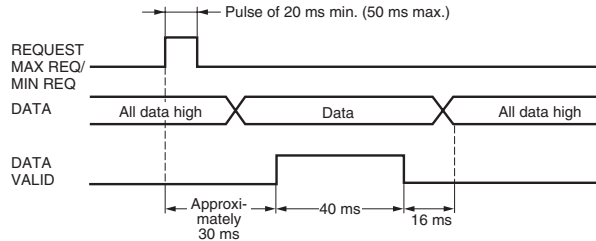

Outputting Continuous Data

While the REQ signal is ON, the DATA signals will be output every 64 ms. If the HOLD input is turned ON while changing between data 1 and data 2, the DATA signals will hold either data 1 or data 2, depending on the timing of the HOLD input. The Data signals will never turn OFF in this case.

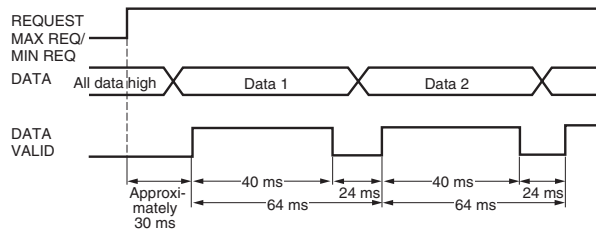

1-2-5 Precautions

- The MAX.REQ. signal and MIN.REQ. signal cannot be used for the K3HB-C.
- The K3HB-C has no HOLD input pin.
- When reading the maximum or minimum value from the Digital Indicator, the data is valid 30 ms after the rising edge of the MAX.REQ signal or MIN.REQ signal. Read data while the D.V. signal is ON.
- The RUN signal is ON while in Run Mode or Test Mode; however, when an error other than an overflow or an underflow occurs, the RUN signal turns OFF. When the RUN signal is not ON, the D.V. signal and DATA signal are also not output.
- When the HOLD input turns ON, the Digital Indicator stops reading inputs and holds the measurement value taken immediately prior to the HOLD input turning ON.

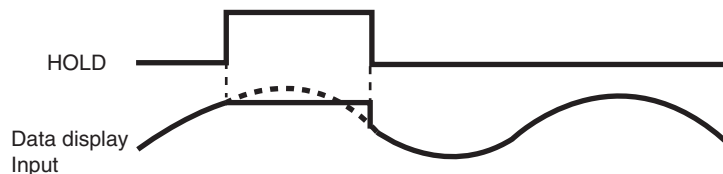

- When the RESET input turns ON, all BCD signals turn OFF.

- In Setup Mode, all BCD data turns OFF.
- When the POL signal is ON, the polarity is negative. When the polarity signal is OFF, the polarity is positive.



- The OVER signal is output when there is a BCD data overflow or underflow. At that time, the display of the Digital Indicator displays flashing numeric values.

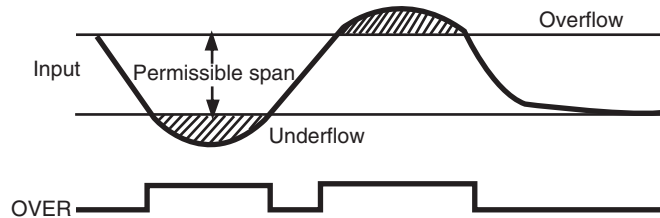

- In Test Mode, the display value that is currently keyed in is output for the REQ signal, MAX signal, or MIN signal.
- The REQ signals from two or more Digital Indicators cannot be input at the same time. Use wired OR connections and offset the timing of REQ signal inputs.

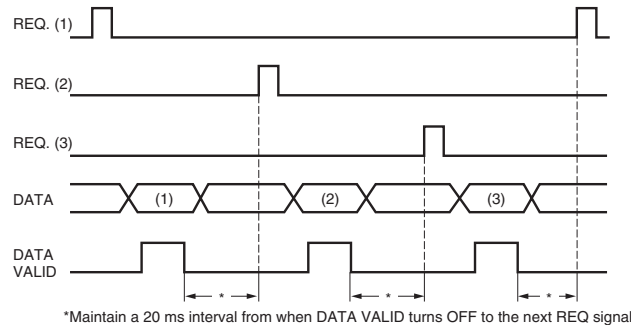
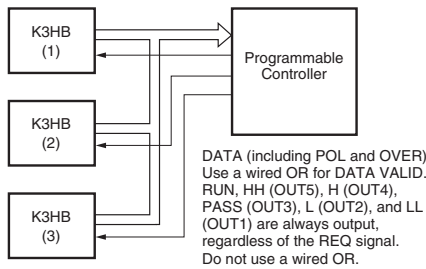

1-3 Accessories

1-3-1 Connectors (Included)

1-3-2 Cable: K32-BCD

External View

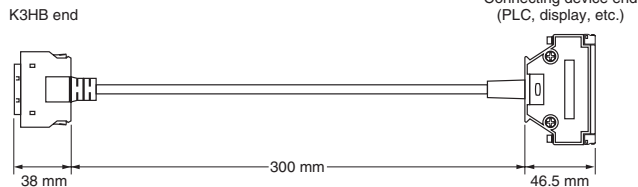

Cover: HDR-ES0LPA5 (made by Honda Tsushin Kogyo Co., Ltd.)
 Connector: HDR-ES0MAG1 (made by Honda Tsushin Kogyo Co., Ltd.)

Connecting device end (PLC, display, etc.)
 D-sub connector (37-pin, female)
 Cover: 17JE-37H-1A (made by DDK)
 Connector: 17JE-13370-02(D1) (made by DDK) applicable pr
 Stud: 17L-002A (made by DDK)

Pin Wiring Diagram

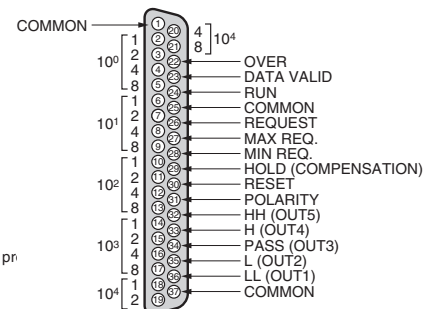

Note D-sub connectors are connected to the BCD output cable.
 Cover: 17JE-37H-1A (made by DDK)
 Connector: 17JE-23370-02(D1) (made by DDK) suitable product

1-3-3 Operating Method

Setting with front keys is not required for models with a BCD output.

1-4 Precautions for BCD Programming

- 1,2,3...
1. With models with a BCD output, only the measurement value, maximum value, or minimum value can be read out.
 2. The "+" and "-" polarity correspond to low and high of the POL signal.
 3. Read data while the D.V. is ON.
 4. Data cannot be written from the PLC to the Digital Indicator.

1-5 Programming Example 1: Connecting to a PLC

The following programming example shows a single Digital Indicator connected to the SYSMAC C500 (OMRON).

1-5-1 I/O Allocations

Pin number	Signal name	Signal direction	Meaning	I/O allocation
1	COM		GND: V0*	
2	RD1-1	Output	1 ↘ Read data 10 ⁰ digit	Input Unit, IR 0000
3	RD1-2	Output	2 ↘ Read data 10 ⁰ digit	Input Unit, IR 0001
4	RD1-4	Output	4 ↘ Read data 10 ⁰ digit	Input Unit, IR 0002
5	RD1-8	Output	8 ↘ Read data 10 ⁰ digit	Input Unit, IR 0003
6	RD2-1	Output	1 ↘ Read data 10 ¹ digit	Input Unit, IR 0004
7	RD2-2	Output	2 ↘ Read data 10 ¹ digit	Input Unit, IR 0005
8	RD2-4	Output	4 ↘ Read data 10 ¹ digit	Input Unit, IR 0006
9	RD2-8	Output	8 ↘ Read data 10 ¹ digit	Input Unit, IR 0007
10*	RD3-1	Output	1 ↘ Read data 10 ² digit	Input Unit, IR 0008
11*	RD3-2	Output	2 ↘ Read data 10 ² digit	Input Unit, IR 0009
12*	RD3-4	Output	4 ↘ Read data 10 ² digit	Input Unit, IR 0010
13*	RD3-8	Output	8 ↘ Read data 10 ² digit	Input Unit, IR 0011
14*	RD4-1	Output	1 ↘ Read data 10 ³ digit	Input Unit, IR 0012
15*	RD4-2	Output	2 ↘ Read data 10 ³ digit	Input Unit, IR 0013
16*	RD4-4	Output	4 ↘ Read data 10 ³ digit	Input Unit, IR 0014
17*	RD4-8	Output	8 ↘ Read data 10 ³ digit	Input Unit, IR 0015
18*	RD5-1	Output	1 ↘ Read data 10 ⁴ digit	Input Unit, IR 0100
19*	RD5-2	Output	2 ↘ Read data 10 ⁴ digit	Input Unit, IR 0101
20*	RD5-4	Output	4 ↘ Read data 10 ⁴ digit	Input Unit, IR 0102
21*	RD5-8	Output	8 ↘ Read data 10 ⁴ digit	Input Unit, IR 0103
22*	OVER	Output	Data overflow, data underflow	Input Unit, IR 0104*
23*	D-V	Output	Data valid signal	Input Unit, IR 0105
24*	RUN	Output	RUN signal	Input Unit, IR 0106
25*	COM		GND: V0*	
26*	REQ	Input	Measurement value output request	Output Unit, IR 0200
27*	MAX	Input	Maximum value output request	Output Unit, IR 0201*

Pin number	Signal name	Signal direction	Meaning	I/O allocation
28*	MIN	Input	Minimum value output request	Output Unit, IR 0202*
29*	HOLD	Input	HOLD input	Output Unit, IR 0203*
30*	RESET	Input	RESET input	Output Unit, IR 0204*
31	POL	Output	Data polarity signal	Input Unit, IR 0107

- Note**
- (1) I/O allocations marked with an asterisk are not used in this programming example.
 - (2) The pin numbers shown in the above table are the pin numbers of the D-sub connector on the special BCD output cable (sold separately).

1-5-2 DM (Data Memory) Area

Read data is stored in the memory, as shown below.

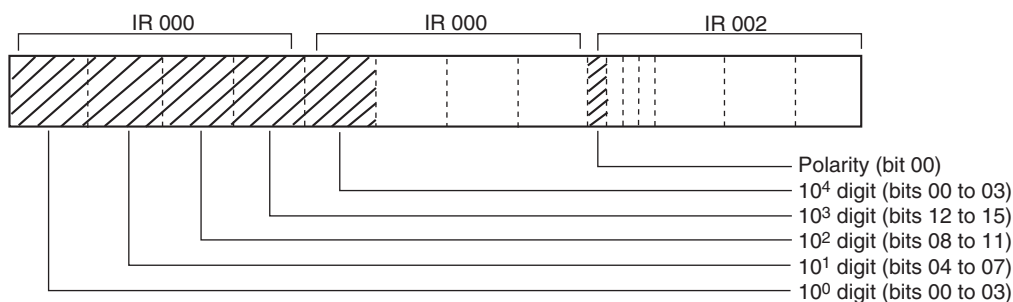

1-5-3 Operation

In this programming example, IR 00113 in the CPU Unit of the PLC is turned ON to read the measurement value of the Digital Indicator to the PLC and store it in the DM area. No matter how long IR 00113 remains ON, data is sampled only once.

1-5-4 Timing Chart

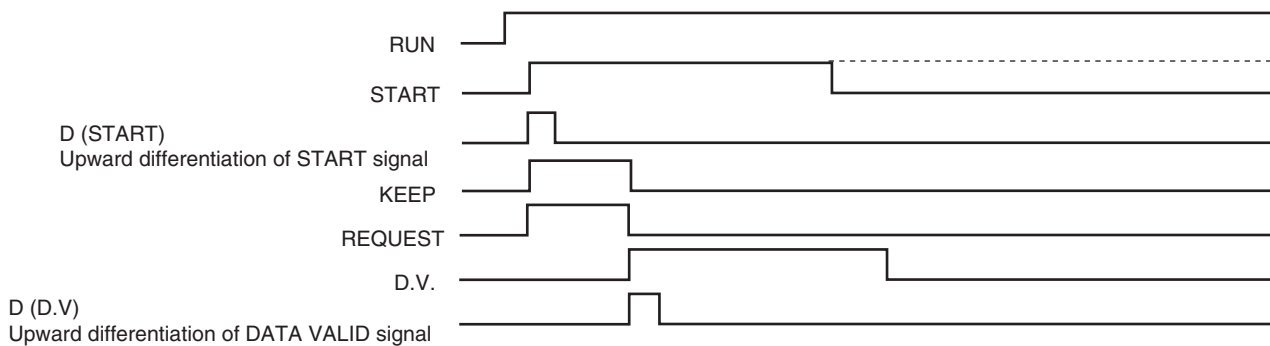

1-5-5 Ladder Programming

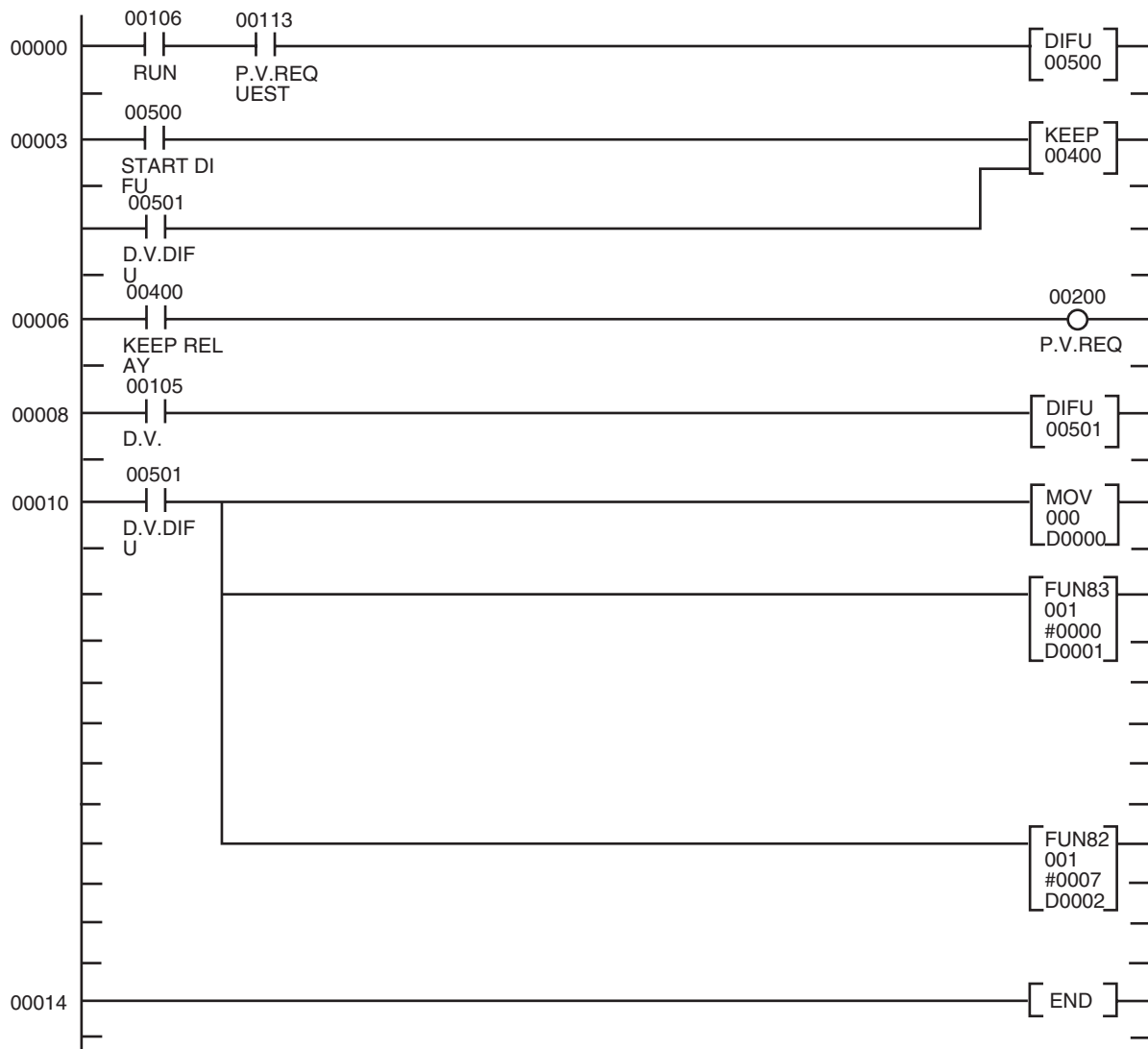

1-6 Programming Example 2: Connecting to a PLC

The following programming example shows three Digital Indicators connected to the SYSMAC C500 (OMRON).

1-6-1 I/O Allocations

Pin number			Signal name	Signal direction	Meaning	I/O allocation
DPM-A	DPM-B	DPM-C				
1	1	1	COM		GND: V0	Input Unit, IR 0000
2	2	2	RD1-1	Output	1 ↘ Read data 10 ⁰ digit	Input Unit, IR 0001
3	3	3	RD1-2	Output	2 ↘ Read data 10 ⁰ digit	Input Unit, IR 0002
4	4	4	RD1-4	Output	4 ↘ Read data 10 ⁰ digit	Input Unit, IR 0003
5	5	5	RD1-8	Output	8 ↘ Read data 10 ⁰ digit	Input Unit, IR 0004
6	6	6	RD2-1	Output	1 ↘ Read data 10 ¹ digit	Input Unit, IR 0005
7	7	7	RD2-2	Output	2 ↘ Read data 10 ¹ digit	Input Unit, IR 0006
8	8	8	RD2-4	Output	4 ↘ Read data 10 ¹ digit	Input Unit, IR 0007
9	9	9	RD2-8	Output	8 ↘ Read data 10 ¹ digit	Input Unit, IR 0008
10*	10*	10*	RD3-1	Output	1 ↘ Read data 10 ² digit	Input Unit, IR 0009
11*	11*	11*	RD3-2	Output	2 ↘ Read data 10 ² digit	Input Unit, IR 0010
12*	12*	12*	RD3-4	Output	4 ↘ Read data 10 ² digit	Input Unit, IR 0011
13*	13*	13*	RD3-8	Output	8 ↘ Read data 10 ² digit	Input Unit, IR 0012
14*	14*	14*	RD4-1	Output	1 ↘ Read data 10 ³ digit	Input Unit, IR 0013
15*	15*	15*	RD4-2	Output	2 ↘ Read data 10 ³ digit	Input Unit, IR 0014
16*	16*	16*	RD4-4	Output	4 ↘ Read data 10 ³ digit	Input Unit, IR 0015
17*	17*	17*	RD4-8	Output	8 ↘ Read data 10 ³ digit	Input Unit, IR 0100
18*	18*	18*	RD5-1	Output	1 ↘ Read data 10 ⁴ digit	Input Unit, IR 0101
19*	19*	19*	RD5-2	Output	2 ↘ Read data 10 ⁴ digit	Input Unit, IR 0102
20*	20*	20*	RD5-4	Output	4 ↘ Read data 10 ⁴ digit	Input Unit, IR 0103
21*	21*	21*	RD5-8	Output	8 ↘ Read data 10 ⁴ digit	Input Unit, IR 0104*
22*	22*	22*	OVER	Output	Data overflow, data underflow	Input Unit, IR 0105
23*	---	---	D-V	Output	Data valid signal A	Input Unit, IR 0106
24*	---	---	RUN	Output	RUN signal A	Input Unit, IR 0109
---	23	---	D-V	Output	Data valid signal B	Input Unit, IR 0110
---	24	---	RUN	Output	RUN signal B	Input Unit, IR 0111
---	---	23	D-V	Output	Data valid signal C	Input Unit, IR 0112
---	---	24	RUN	Output	RUN signal C	
25	25	25	COM		GND: V0	Output Unit, IR 0200
26	---	---	REQ	Input	PV output request A	Output Unit, IR 0201
---	26	---	REQ	Input	PV output REQUEST B	Output Unit, IR 0202
---	---	26	REQ	Input	PV output REQUEST C	Output Unit, IR 0203*
27	---	---	MAX	Input	Peak value output REQUEST A	Output Unit, IR 0204*
---	27	---	MAX	Input	Peak value output REQUEST B	Output Unit, IR 0205*
---	---	27	MAX	Input	Peak value output REQUEST C	Output Unit, IR 0206*
28	---	---	MIN	Input	Peak value output REQUEST A	Output Unit, IR 0207*
---	28	---	MIN	Input	Peak value output REQUEST B	Output Unit, IR 0208*
---	---	28	MIN	Input	Peak value output REQUEST C	Output Unit, IR 0209*

Pin number			Signal name	Signal direction	Meaning	I/O allocation
DPM-A	DPM-B	DPM-C				
29	---	---	HOLD	Input	HOLD input A	Output Unit, IR 0210*
---	29	---	HOLD	Input	HOLD input B	Output Unit, IR 0211*
---	---	29	HOLD	Output	HOLD input C	
30	---	---	RESET	Input	RESET input A	Output Unit, IR 0212*
---	30	---	RESET	Input	RESET input B	Output Unit, IR 0213*
---	---	30	RESET	Input	RESET input C	Output Unit, IR 0214*
31	31	31	POL	Output	Data polarity signal	Output Unit, IR 0107

- Note**
- (1) I/O allocations marked with an asterisk are not used in this programming example.
 - (2) The pin numbers shown in the above table are the pin numbers of the D-sub connector on the special BCD output cable (sold separately).

1-6-2 DM (Data Memory) Area

Read data is stored in the memory, as shown below.

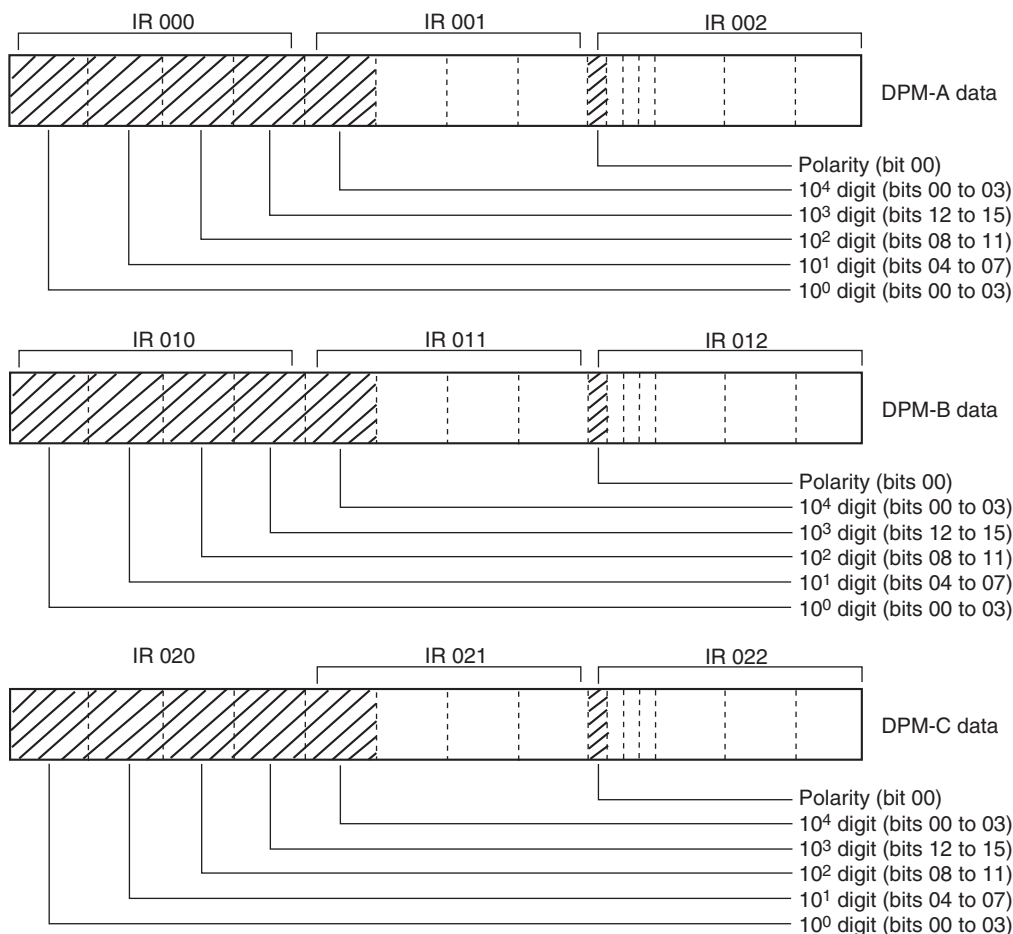

1-6-3 Operation

In this programming example, IR 00113 in the CPU Unit of the PLC is turned ON to read the measurement value of the three Digital Indicators (A, B and C) to the PLC and store them in the DM area. No matter how long IR 00113 remains ON, data is sampled only once for each of Digital Indicators A, B and C.

1-6-4 Timing Chart

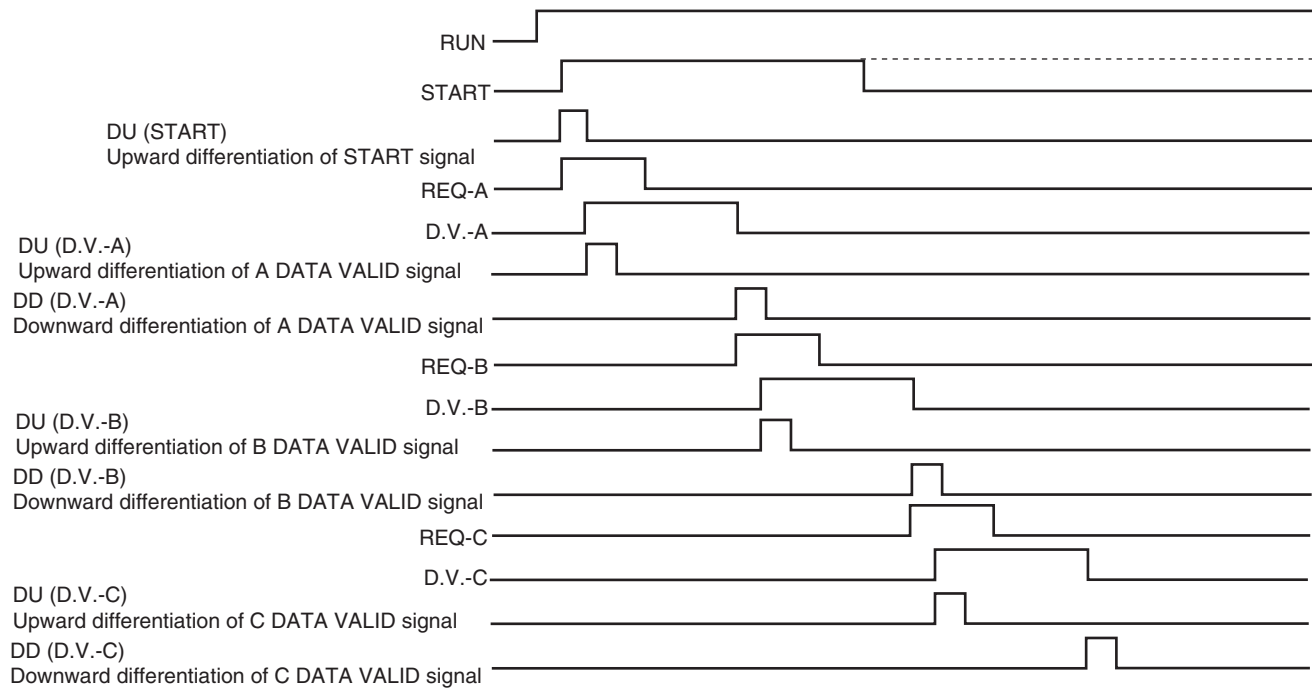

1-6-5 Ladder Programming

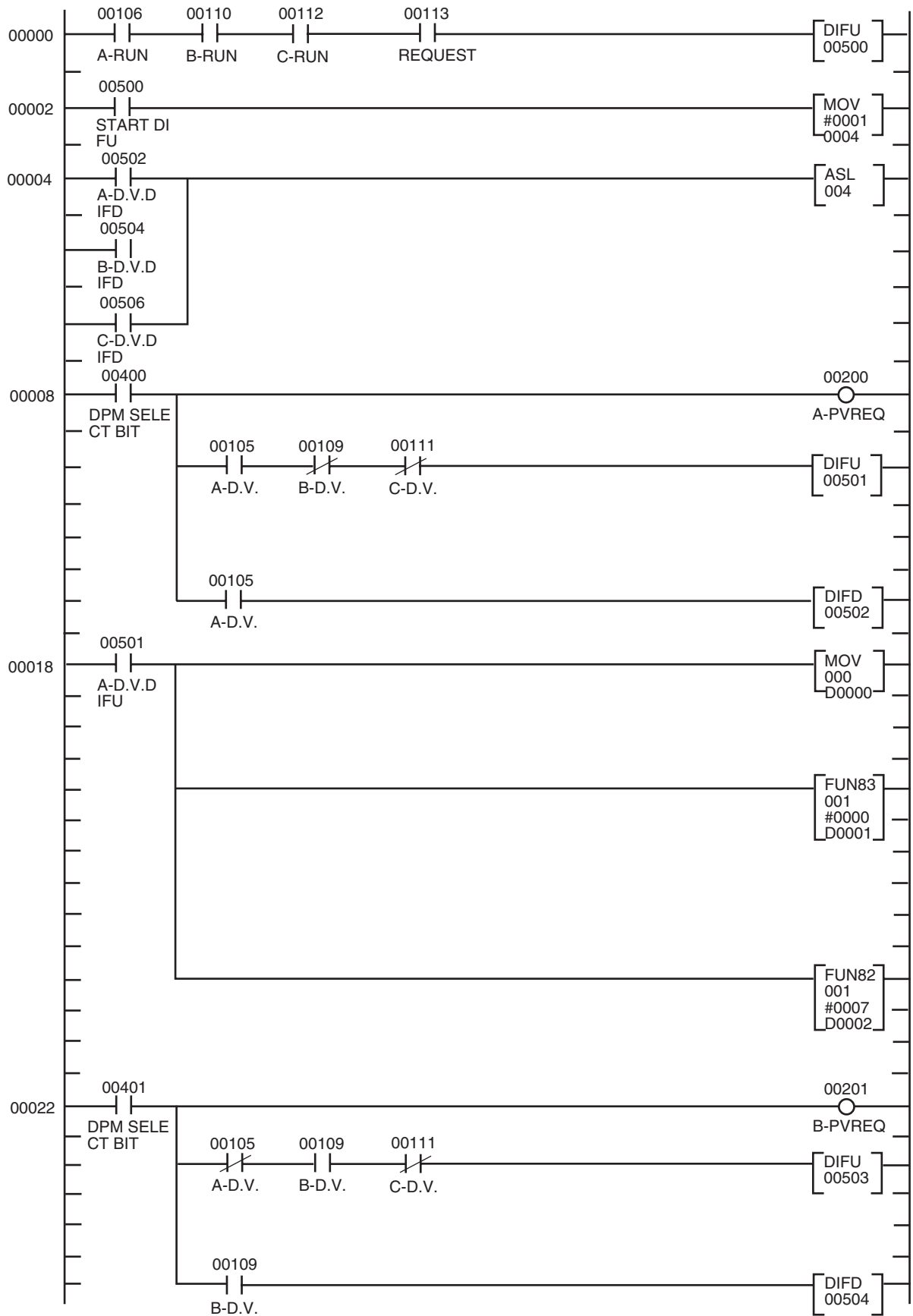

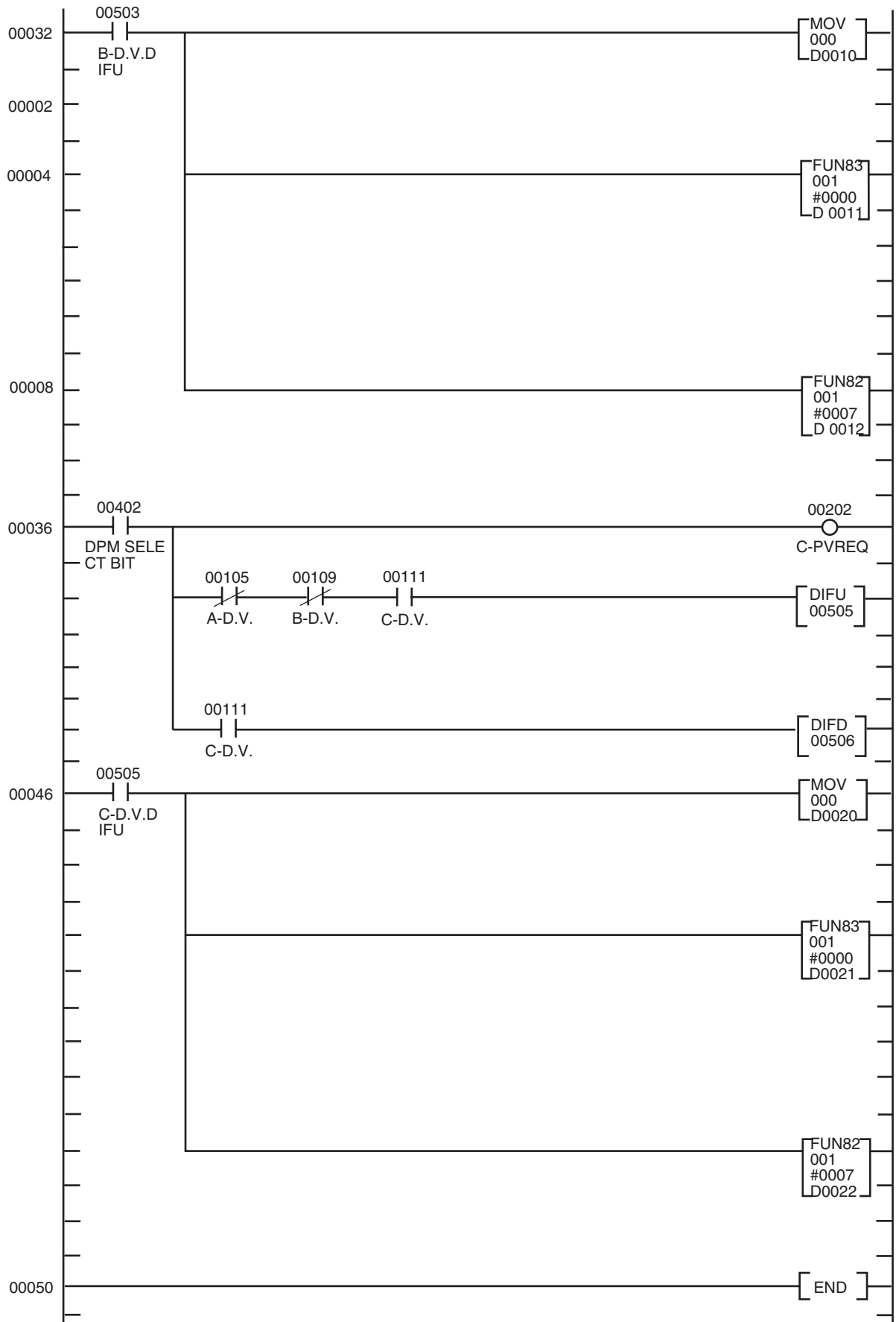

Index

A

accessories
 BCD communications, 11-6
addresses (CompoWay/F communications), 1-8
advanced function setting level, 2-10

B

Bank Selection, 1-18
baud rate
 automatic detection, 3-3
BCD communications, 11-1
 accessories, 11-6
 cables, 11-6
 connection example, 11-2
 connectors, 11-6
 data overflow, 11-6
 data underflow, 11-6
 DM Area, 11-8, 11-11
 I/O allocations, 11-7, 11-10
 I/O ratings, 11-3
 ladder programming, 11-9, 11-13
 operation, 11-7, 11-8, 11-11
 overview, 11-2
 precautions, 11-5
 programming example for PLC connection, 11-7, 11-10
 specifications, 11-3
 timing charts, 11-5, 11-8, 11-12
bit strobe, 10-2

C

cables
 BCD communications, 11-6
 communications cables
 models, 10-7
change of state (COS), 10-2
cleaning, 9-3
command block, 7-3, 7-5, 7-6
commands
 Bank Selection, 1-18
 CompoWay/F ASCII commands, 7-3, 7-5
 CompoWay/F binary commands, 7-3, 7-5
 CompoWay/F communications, 1-13
 Controller Status Read (CompoWay/F communications), 1-21
 Echo Back Test, 1-22
 Initialize Settings, 1-20

 Monitor Value Read (CompoWay/F communications), 1-13
 Monitor Value/Setting Data Compound Read (CompoWay/F communications), 1-14
 Monitor Value/Setting Data Compound Read Store (Write), 1-16
 Monitor Value/Setting Data Compound Store Read, 1-17
 Move to Protect Level, 1-20
 Move to Setting Area 1, 1-20
 Read Machine Attributes, 1-21
 Reset, 1-18
 Setting Data Compound Write (CompoWay/F communications), 1-16
 Setting Data Read (CompoWay/F Communications), 1-13
 Setting Data Write (CompoWay/F communications), 1-15
 Software Reset, 1-19
 Write Via Communication, 1-18
 Zero Execute/Cancel, 1-19
communications
 connection example, 3-2
 connection example for BCD communications, 11-2
 cycle time, 8-3
 distance, 3-5
 performance, 8-1
 specifications, 3-5
communications cables, 10-7
 DeviceNet, 10-7
 preparing, 5-4
 wiring, 5-4
communications monitoring settings, 2-3
Communications Power Voltage Monitor Error Flag, 4-4, 6-5
communications setting level, 2-10
communications specifications, 1-2
comparative set value level, 2-7
CompoWay/F
 commands, 7-4
 communications method, 1-2
CompoWay/F ASCII commands, 7-3, 7-5
CompoWay/F binary commands, 7-3, 7-5
CompoWay/F commands, 7-2
Configurator
 operations, 4-2
connection types, 10-2
connections
 hardware, 10-7
connectors
 attaching, 5-6

BCD communications, 11-6
models, 10-8
Controller Status Read (CompoWay/F communications),
1-21
crimp terminals, 5-4, 10-8
models, 10-8
current consumption, 3-6
cyclic, 10-2

D

data overflow
BCD communications, 11-5
DATA signal
BCD communications, 11-5
data underflow
BCD communications, 11-5
Data Valid signal
BCD communications, 11-5
device profiles, 10-3
DeviceNet Communications Unit connector, 5-6
DeviceNet connector, 5-2, 10-8
dimensions, 5-2
display adjustment level, 2-7
DM Area
BCD communications, 11-8, 11-11

E

EC Directives, 1-xiii
conformance, 1-xiii
Echo Back Test, 1-22
EMC Directives, 1-xiii
end codes (CompoWay/F communications), 1-6
error codes, 7-4
explicit messages, 3-3, 7-2
basic format, 7-3
error codes, 7-4
General Status Read, 7-7
Maintenance Counter Save, 7-7
sending, 7-6
specific to DeviceNet, 7-6
types, 7-2
Unit Conduction Time or Total RUN Time Read, 7-7

F

FINS-mini service commands, 1-7

frame configuration (CompoWay/F communications), 1-5
frames
CompoWay/F communications, 1-5

G

general status, 6-5

H

HOLD input
BCD communications, 11-5

I

I/O allocations, 6-2
area size, 6-3
BCD communications, 11-7, 11-10
default values, 6-4
parameters, 6-3
settings, 6-4
I/O ratings
BCD communications, 11-3
I/O response time, 8-2
IN Area, 6-4
indicators, 5-3, 9-2
troubleshooting, 9-2
initial setting level, 2-4
Initialize Settings, 1-20
input adjustment level, 2-6
inspection, 9-3

L

ladder programming
BCD communications, 11-9, 11-13
linear output level, 2-9

M

maintenance, 9-1, 9-3
replacing Units, 9-4
MAX.REQ signal
BCD communications, 11-5
message communications time, 8-6
MIN.REQ signal
BCD communications, 11-5

module status (MS indicator), 5-3
Monitor Value Read (CompoWay/F communications), 1-13
Monitor Value/Setting Data Compound Read (CompoWay/F communications), 1-14
Monitor Value/Setting Data Compound Read Store (Write), 1-16
Monitor Value/Setting Data Compound Read Store Check (Read), 1-17
Monitor Value/Setting Data Compound Store Read, 1-17
Move to Protect Level, 1-11, 1-20
Move to Setting Area 1, 1-12, 1-20

N

network power monitor, 4-4
network status (NS indicator), 5-3
networks
 multiple masters, 8-4
node addresses
 setting, 4-3

O

One-branch Power Supply Taps, 10-9
One-branch Taps, 10-9
operation
 BCD communications, 11-7, 11-8
 commands, 1-11, 6-6
 CompoWay/F communications, 1-11
 data, 6-3
 example, 1-24
 explicit messages, 7-2
 parameters, 6-3
 programming example, 6-7
 remote I/O, 3-4
OUT Area, 6-4
Output Enable Bits, 3-4, 6-4, 6-5
OVER signal
 BCD communications, 11-6

P

part names, 5-2
POL signal
 BCD communications, 11-6
poll, 10-2
precautions, 1-ix, 1-xi
 BCD communications, 11-5

BCD programming, 11-7
 definitions, 1-viii
 replacing Digital Indicators, 9-4
programming
 samples, 6-7
protect level, 2-3
Protect Level Setting Data Write, 1-15

R

Read Machine Attributes, 1-21
refresh processing time, 8-4
replacing Units, 9-4
REQ signal
 BCD communications, 11-5
Reset, 1-18
RESET input
 BCD communications, 11-5
response block, 7-3, 7-5, 7-6
responses
 CompoWay/F communications, 1-13
RUN level, 2-3
RUN signal
 BCD communications, 11-5
RUN/adjustment protection, 2-11

S

sampling data
 BCD communications, 11-5
service commands
 CompoWay/F communications, 1-7
setting areas, 1-12, 1-20
Setting Data Compound Write (CompoWay/F communications), 1-16
Setting Data Read (CompoWay/F communications), 1-13
Setting Data Write (CompoWay/F communications), 1-15
setup mode
 BCD communications, 11-6
setup procedure, 4-2
Shielded T-branch Connectors, 10-9
Software Reset, 1-11, 1-19, 6-6
specifications
 BCD communications, 11-3
 communications, 3-5
 DeviceNet, 10-2
 general, 3-6

startup procedure, 4-2
startup time, 8-5
strobe, 6-6, 6-7
supply voltage, 3-6
system startup time, 8-5

T

T-branch Taps, 10-9
Terminating Resistors, 10-8
test mode
 BCD communications, 11-5
Three-branch Taps, 10-9
timing charts
 BCD communications, 11-5, 11-8, 11-12
transfer protocol (CompoWay/F communications), 1-2
troubleshooting, 9-1

U

Unit conduction time monitor, 4-4
Unit Maintenance Flag, 6-5

V

variable areas, 1-8

W

wiring, 5-4
wiring diagrams, 1-3
Write via Communications, 1-18

Z

Zero Execute/Cancel, 1-19

Revision History

A manual revision code appears as a suffix to the catalog number on the front cover of the manual.

Cat. No. N129-E1-03



Revision code

The following table outlines the changes made to the manual during each revision. Page numbers refer to the previous version.

Revision code	Date	Revised content
01	February 2004	Original production
02	October 2004	Page ix: Model numbers added. Page xii: Sentence added to item number 19. Page 1-14: Variable types removed, address range changed. Page 1-15: Scaling level added, address range changed in second table. Page 1-16: Variable types removed and address range changed in first and second tables. Page 1-21: Data for new models added to first table. Page 2-10: Settings for new models added. Page 6-4: Modifications to table, including additions and changes of items and columns. Page 11-1: Section on BCD output added.
03	March 2005	Pages 2-3 to 2-10: Changed EU to --- in tables. Pages 2-11 to 2-15: Replaced tables with those for the K3HB-RP and K3HB-C.

