



General Specifications

Item	DRT2-ID16S (-1)	DRT2-MD16S (-1)
Communications power supply voltage	11 to 25 VDC (Supplied from communications connector.)	
I/O power supply voltage	Supplied from communications connector; output supplied from external source.	
Communications power supply current consumption	230 mA max.	135 mA max.
Dielectric strength	500 VAC (between isolated circuits)	
Noise immunity	2 kV on power supply line (conforming to IEC61000-4-4)	
Vibration resistance	10 to 56 Hz, 0.7-mm double amplitude, 56 to 150 Hz, acceleration: 50 m/s ²	
Shock resistance	150 m/s ²	
Mounting methods	M4 screw mounting or DIN Track mounting	
Tightening torque	M4 screws: 0.6 to 0.98 Nm	
Ambient operating temperature	-10 to 55°C	
Ambient operating humidity	35% to 85% (with no condensation)	
Storage temperature	-20 to 65°C.	
Weight	90 g max.	95 g max.

Standard Models

Model number	Specifications
DRT2-ID16S	16 inputs, NPN
DRT2-ID16S-1	16 inputs, PNP
DRT2-MD16S	8 inputs/8 outputs, NPN
DRT2-MD16S-1	8 inputs/8 outputs, PNP

Dimensions (mm)

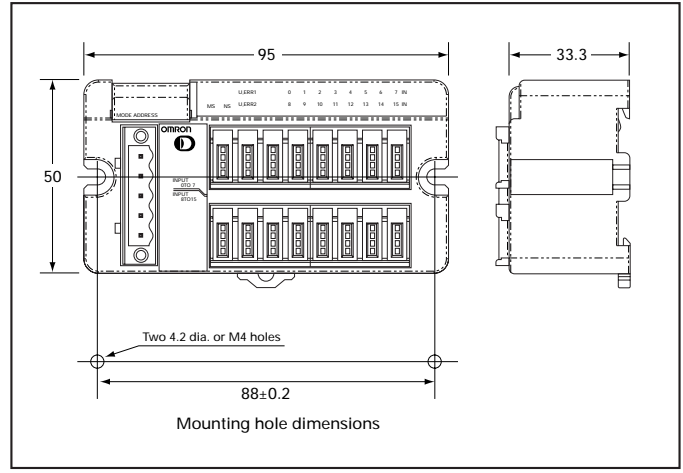

Input Specifications

16 Inputs

Item	Specifications	
Model number	DRT2-ID16S	DRT2-ID16S-1
Internal I/O common processing	NPN	PNP
Number of I/O points	16 inputs	
ON voltage	15 VDC min. (between each input terminal and V)	15 VDC min. (between each input terminal and G)
OFF voltage	5 VDC max. (between each input terminal and V)	5 VDC max. (between each input terminal and G)
OFF current	1.0 mA max.	
Input current	11.0 mA max. per point at 24 VDC 3.0 mA min. per point at 11 VDC	
ON delay time	1.5 ms max.	
OFF delay time	1.5 ms max.	
Number of circuits	16 inputs/common	

8 Inputs/8 Outputs

Item	Specifications	
Model number	DRT2-MD16S	DRT2-MD16S-1
Internal I/O common processing	NPN	PNP
Number of I/O points	8 inputs (0 to 7)	
ON voltage	9 VDC min. (between each input terminal and V) 1.5 ms max.	9 VDC min. (between each input terminal and G)
OFF voltage	5 VDC min. (between each input terminal and V)	5 VDC min. (between each input terminal and G)
OFF current	1.0 mA max.	
Input current	11 mA max. per point at 24 VDC 3.0 mA min. per point at 11 VDC	
ON delay time	1.5 ms max.	
OFF delay time	1.5 ms max.	
Number of circuits	8 points per common	
Sensor short-circuit detection current	100 mA min. (per point)	

Output Specifications

8 Inputs/8 Outputs

Item	Specifications	
Model number	DRT2-MD16S	DRT2-MD16S-1
Internal I/O common processing	NPN	PNP
Number of I/O points	8 outputs (8 to 15)	
Rated output	0.3 A per point, 2.4 A per common	0.3 A per point, 1.6 A per common
Residual voltage and current	2 V max. at 0.3 ADC, between each output terminal and G	2 V max. at 0.3 ADC, between each output terminal and V
Leakage current	0.1 mA max.	
ON delay time	1.5 ms max.	
OFF delay time	1.5 ms max.	
Number of circuits	8 points per common	
Load short-circuit detection current	2.4 A min. per common	1.6 A min. per common

This catalog mainly provides information that is necessary for selecting suitable models, and does not contain precautions for correct use. Always read the precautions and other required information provided in product operation manuals before using the product.

- The application examples provided in this catalog are for reference only. Check functions and safety of the equipment before use.
- Never use the products for any application requiring special safety requirements, such as nuclear energy control systems, railroad systems, aviation systems, medical equipment, amusement machines, vehicles, safety equipment, or other application involving serious risk to life or property, without ensuring that the system as a whole has been designed to address the risks, and that the OMRON products are properly rated and installed for the intended use within the overall equipment or system.

DeviceNet™ Smart Slave

Sensor Connector Terminal

DRT2-□D16S(-1)

Remote Maintenance with DeviceNet Smart Slaves Equipped with Industry-standard Sensor Connectors

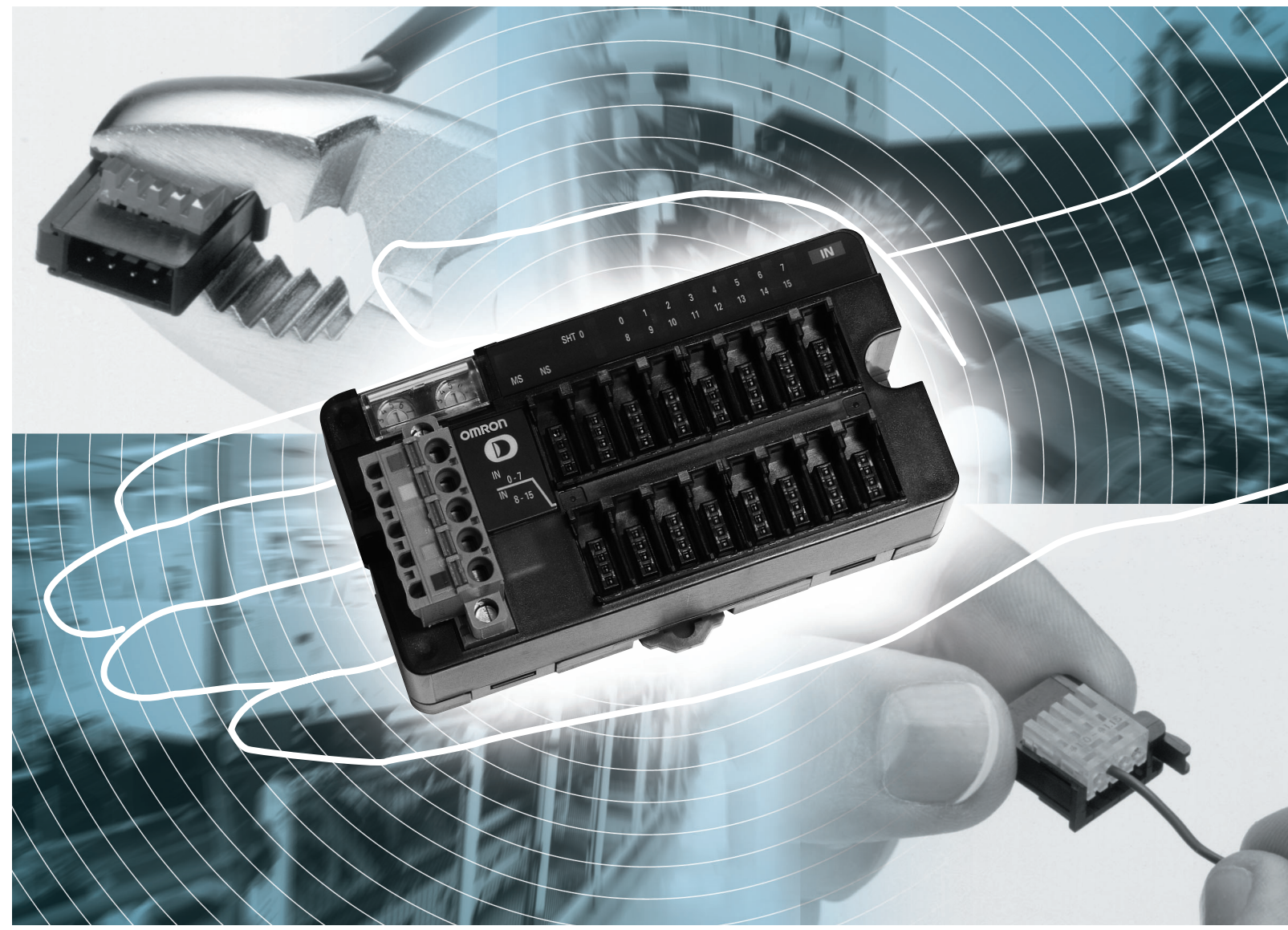

Warranty and Limitations of Liability

WARRANTY
OMRON's exclusive warranty is that the products are free from defects in materials and workmanship for a period of one year (or other period if specified) from date of sale by OMRON.

OMRON MAKES NO WARRANTY OR REPRESENTATION, EXPRESS OR IMPLIED, REGARDING NON-INFRINGEMENT, MERCHANTABILITY, OR FITNESS FOR PARTICULAR PURPOSE OF THE PRODUCTS. ANY BUYER OR USER ACKNOWLEDGES THAT THE BUYER OR USER ALONE HAS DETERMINED THAT THE PRODUCTS WILL SUITABLY MEET THE REQUIREMENTS OF THEIR INTENDED USE. OMRON DISCLAIMS ALL OTHER WARRANTIES, EXPRESS OR IMPLIED.

LIMITATIONS OF LIABILITY
OMRON SHALL NOT BE RESPONSIBLE FOR SPECIAL, INDIRECT, OR CONSEQUENTIAL DAMAGES, LOSS OF PROFITS, OR COMMERCIAL LOSS IN ANY WAY CONNECTED WITH THE PRODUCTS, WHETHER SUCH CLAIM IS BASED ON CONTRACT, WARRANTY, NEGLIGENCE, OR STRICT LIABILITY.

In no event shall the responsibility of OMRON for any act exceed the individual price of the product on which liability is asserted.

IN NO EVENT SHALL OMRON BE RESPONSIBLE FOR WARRANTY, REPAIR, OR OTHER CLAIMS REGARDING THE PRODUCTS UNLESS OMRON'S ANALYSIS CONFIRMS THAT THE PRODUCTS WERE PROPERLY HANDLED, STORED, INSTALLED, AND MAINTAINED AND NOT SUBJECT TO CONTAMINATION, ABUSE, MISUSE, OR INAPPROPRIATE MODIFICATION OR REPAIR.

Note: Do not use this document to operate the Unit.

<p>OMRON Corporation FA Systems Division H.Q. 66 Matsumoto Mishima-city, Shizuoka 411-8511 Japan Tel: (81)55-977-9181 Fax: (81)55-977-9045</p>	<p>Regional Headquarters</p> <p>OMRON EUROPE B.V. Wegalaan 67-69, NL-2132 JD Hoofddorp The Netherlands Tel: (31)2356-81-300/Fax: (31)2356-81-388</p> <p>OMRON ELECTRONICS LLC 1 East Commerce Drive, Schaumburg, IL 60173 U.S.A. Tel: (1)847-843-7900/Fax: (1)847-843-8568</p> <p>OMRON ASIA PACIFIC PTE. LTD. 83 Clemenceau Avenue, #11-01, UE Square, Singapore 239920 Tel: (65)6835-3011/Fax: (65)6835-2711</p>	<p>Authorized Distributor:</p>	<p>Note: Specifications subject to change without notice. Cat. No. R105-E1-02 Printed in Japan 0304-1M</p>
---	--	---------------------------------------	--

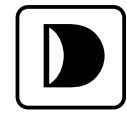

**Innovation
in the Solution Age**

OMRON INDUSTRIAL AUTOMATION

Industry-standard Sensor Connectors

Easy Wiring for I/O Connections

- Industry-standard sensor connectors simplify wiring because the connector's I/O wires can all be crimped at once.
- The OMRON Sensors listed below are available with e-CON connectors already attached.

Simple Crimping



All I/O points have a common terminal, so an intermediate terminal is not needed!

Compatible Connectors

The Compatible Connectors are sold separately.

OMRON Connectors

Model number	Specifications	Appropriate wire size
XN2A-1430	Spring clamp	28 to 20 AWG (0.08 to 0.5 mm ²); Outer diameter including insulation: 1.5 mm max.

Tyco Electronics AMP Connectors

Model number	Specifications/Housing color	Appropriate wire size
1-1473562-4	Red	28 to 24 AWG (0.08 to 0.2 mm ²); Outer diameter including insulation: 0.9 to 1.0 mm
1473562-4	Yellow	24 to 22 AWG (0.2 to 0.3 mm ²); Outer diameter including insulation: 1.0 to 1.15 mm
2-1473562-4	Blue	22 to 20 AWG (0.3 to 0.5 mm ²); Outer diameter including insulation: 1.15 to 1.35 mm

Sumitomo 3M Connectors

Model number	Specifications/Housing color	Appropriate wire size
37104-3101-000FL	Red	26 to 24 AWG (0.14 to 0.2 mm ²); Outer diameter including insulation: 0.8 to 1.0 mm
37104-3122-000FL	Yellow	26 to 24 AWG (0.14 to 0.2 mm ²); Outer diameter including insulation: 1.0 to 1.2 mm
37104-3163-000FL	Orange	26 to 24 AWG (0.14 to 0.2 mm ²); Outer diameter including insulation: 1.2 to 1.6 mm
37104-2124-000FL	Green	22 to 20 AWG (0.3 to 0.5 mm ²); Outer diameter including insulation: 1.0 to 1.2 mm
37104-2165-000FL	Blue	22 to 20 AWG (0.3 to 0.5 mm ²); Outer diameter including insulation: 1.2 to 1.6 mm
37104-2206-000FL	Gray	22 to 20 AWG (0.3 to 0.5 mm ²); Outer diameter including insulation: 1.6 to 2.0 mm

Compatible Sensors

(With Industry-standard Sensor Connectors (Male))

Photoelectric Sensors with Built-in Amplifier

- E3Z-□□□-ECON
- E3T-□□□-ECON

Photomicrosensors

- EE-SX77□□-ECON
- EE-SX87□□-ECON

Extension Cables

- E39-ECON□□□ (Female E-CON connector on one end.)
- E39-ECONW□□□ (Female E-CON connector on one end, male E-CON connector on the other end.)



Pin number	Signal name (color)
1	12 to 24 VDC (brown)
2	Open
3	0 V (blue)
4	Control output (black)

Sensor model	Cable lengths
E3Z series	0.3 m, 0.5 m, or 2 m
E3T series EE-SX series	0.3 m or 2 m

Example model numbers

- E3Z-T61-ECON 0.3m
- E3T-FT11-ECON 2m
- E39-ECON2M
- E39-ECONW0.5M



Pin number	Extension Cable color
1	Brown
2	White
3	Blue
4	Black

Sensor model	Cable lengths
E39-ECON□□□	2 m or 5 m
E39-ECONW□□□	0.5 to 2 m (in 0.1-m increments)

Smart Functions

The Terminals provide smart functions that improve remote maintenance. A variety of information can be collected for maintenance systems without influencing control systems and productivity.

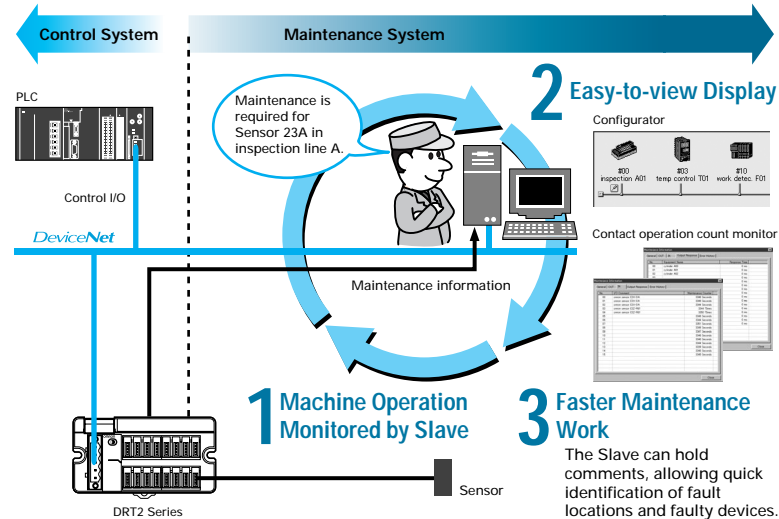

List of Functions

○: Supported; -: Not supported.

Function	Model	
	Connector (e-CON)	Terminal
Operation time monitor	-	○
Contact operation counter (See note.)	○	○
Unit conduction time monitor	○	○
Total ON time monitor (See note.)	○	○
Slave comment/ I/O comments	○	○
Network power voltage monitor	○	○
I/O power status monitor	-	-
Communications error history monitor	○	○
Input filter	○	○
Sensor inrush current prevention	○	○
Detection of sensor power short-circuit	○	○
Detection of external load short-circuit	-	○
Automatic baud rate	○	○

The contact operation counter and total ON time monitor cannot be used simultaneously.

Reduced Wiring

No power supply wiring is required for input devices, such as sensors.

Power supply wiring for communications, Slaves, and I/O devices can be unified into a single wiring system.

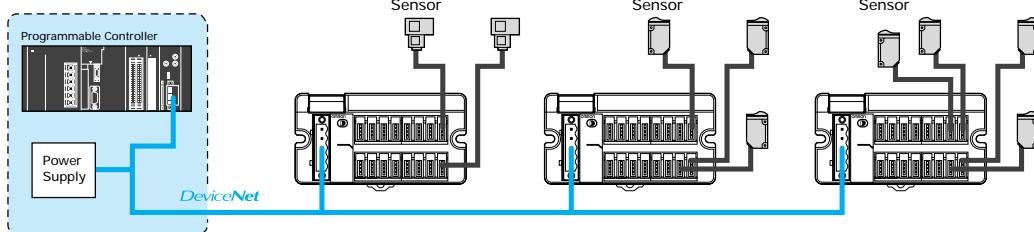

Detect Short-circuits to Prevent the System from Going Down

Short-circuits in the power supply for input devices and output devices are detected for each Unit. Notification of any short-circuits that are detected is provided as part of status information. This allows stable and continuous operation of the system.

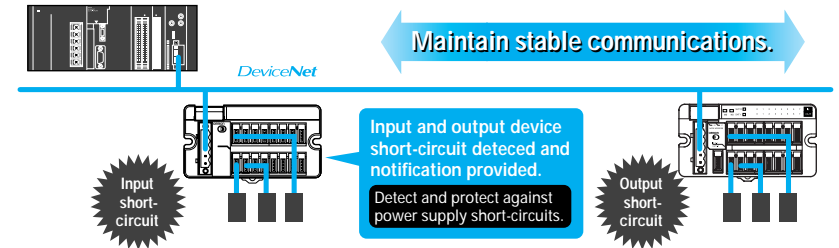

Internal Circuit Diagrams

DRT2-ID16S (NPN)

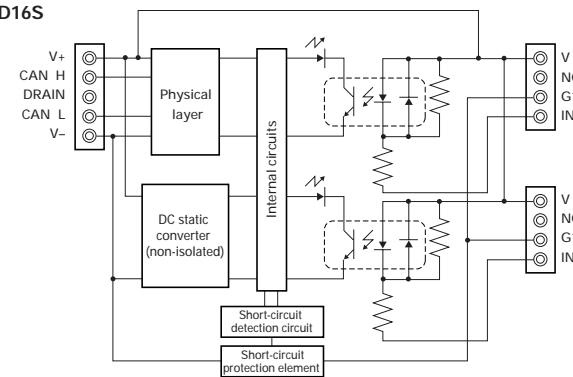

DRT2-ID16S-1 (PNP)

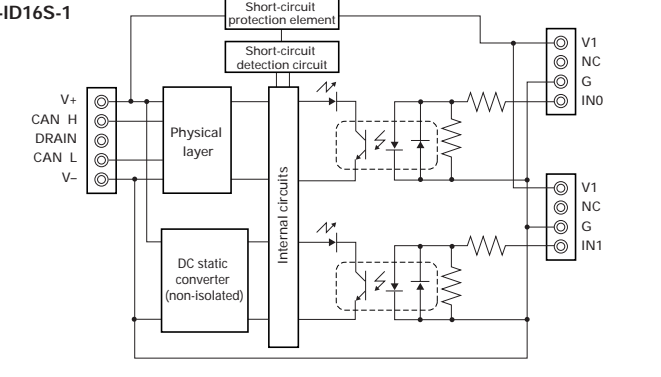

DRT2-MD16S (NPN)

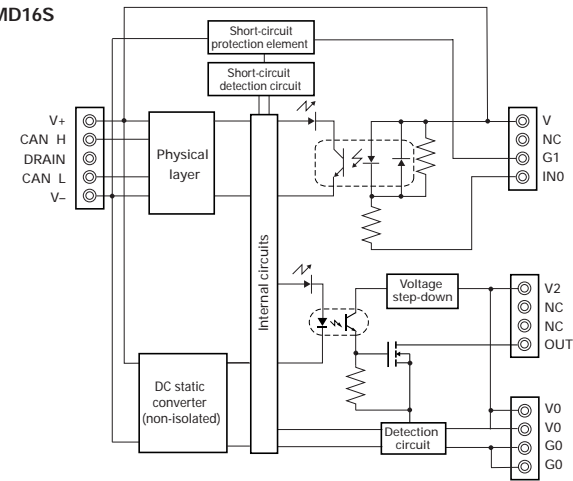

DRT2-MD16S-1 (PNP)

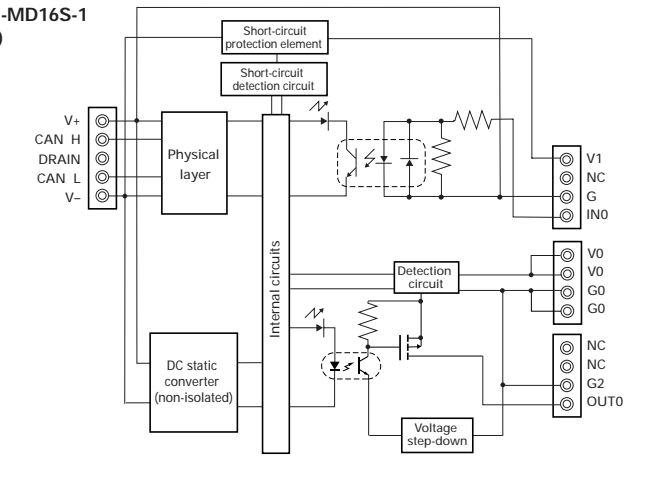

Wiring Diagrams

DRT2-ID16S (NPN)

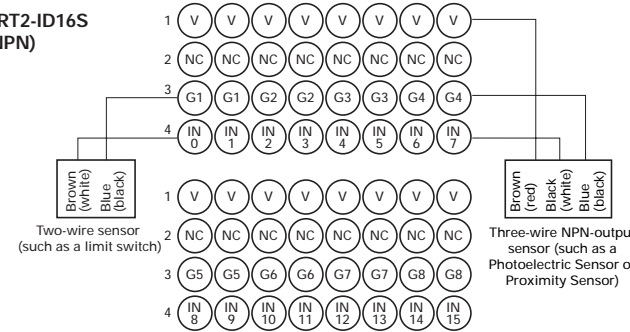

DRT2-ID16S-1 (PNP)

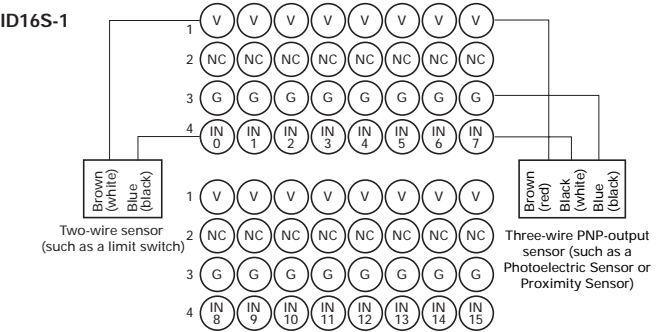

DRT2-MD16S (NPN)

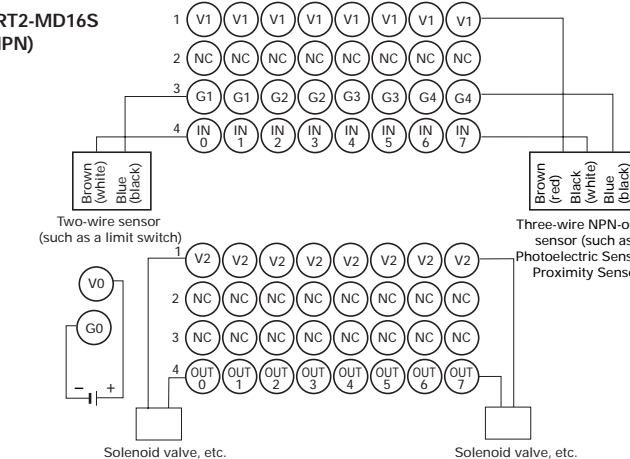

DRT2-MD16S-1 (PNP)

